



All the right connections!®

**USE  
WITH  
CONFIDENCE**

SPECIALISED WIRING ACCESSORIES LTD  
General Catalogue

Trusted by installers since 1988



### Welcome

Here is your copy of the SWA General Catalogue, embracing our comprehensive range of essential terminations, fastenings and tools for the electrical and construction industry.

### Special Edition

This edition is designed to provide easy product selection and essential information on the full range of cable terminations, cable jointing and handling, earthing products, tapes, sealants, lubricants, and aerosols, plus a host of new and innovative products introduced to satisfy the demands of progressive installations.

### Service

Established in 1988 and with over 26 years' experience in terminations and fastenings manufacture and understanding the diverse spectrum of customers' needs, nobody is in a stronger position than SWA to offer a fast and professional service. Our sales team is always ready to answer your queries.

### Quality

SWA products are manufactured under the most stringent quality control systems in full accordance with the latest requirements. Our Quality Assurance engineers will answer any technical problems.

- Quality assured documented system accredited to BS EN ISO 9001:2008.
- Tool hire and repair service accredited to BS EN ISO 9001:2008 standard.
- Tensile testing facilities to ensure product performance and conformity.
- Massive buying power on raw material assuring competitive prices.
- Dedicated customer service team.
- Commitment to technical innovation and new product development.
- Speedy despatch of goods.

### Tool Repair, Calibration & Servicing

SWA offer a tool repair, servicing and calibration service on most leading makes of crimp tooling to ensure tools continue to provide an effective, consistent and prolonged level of performance, all in accordance with ISO 9001 accreditations.



### Introducing:



Fixing Tubs (p33)



Hole Saws (p197)



Scan to visit new website



ATEX



Scan for Company Presentation



SWA Ltd reserve the right to modify the specifications in this catalogue without prior notice.

# CONTENTS 1



## CABLE TERMINATIONS

	Pre-insulated Terminals.....6-14
	Bootlace Ferrules.....15-16
	Copper Tube Terminals.....17-23
	Reduced Palm Heavy Duty Terminal..23
	Shear-Bolt Connectors .....24
	Screw Connectors.....140-143
	Copper Tube Splices.....25
	Copper Pin Terminals.....26
	Selekt-A-Box & Fix-A-Box.....27-31
	Terminal Kit Boxes.....32
	Fixing Tubs.....33
	Aluminium Terminals.....33
	Terminal Connectors.....34-35
	Solar PV Terminals & Tools.....36-37

## MICC PRODUCTS

	MICC Products & Accessories.....39-42
	MICC Tooling.....42

## CABLE GLANDS & ACCESSORIES

	EarthingNuts™.....44
	Taurus™ Range of Cable Glands..45-51

## CABLE GLANDS & ACCESSORIES

	PEX Brass Cable Glands.....52-53
	Premier Brass Cable Glands.....54-58
	Cable Gland Accessories.....65 & 71
	Hazardous Area Cable Glands.....60-64
	Hazardous Area Accessories.....66
	Cable Gland Sizing Charts.....68-72
	Aluminium Cable Glands.....73
	Polyamide Cable Glands.....74-76
	Food Hygiene Glands and Fittings..77-78
	EMC Glands.....79-80

## CABLE FIXINGS

	Fix-A-Box.....30-31
	Nylon Cable Ties.....82-85
	Special Application Cable Ties.....86
	Nylon Cable Tie Accessories.....87-88
	Stainless Steel Cable Ties & Banding.....89-90
	Fire Safety Clips.....90
	Cable Protection Accessories.....91
	Cable Cleats.....92-93
	Aluminium Cable Cleats.....94-96
	Fixing Band.....97



# CONTENTS 2

## CONTENTS 2

### HEATSHRINK & INSULATION SLEEVING

-  Standard Grade Polyolefin Heatshrink..... 100-104
-  Heatshrink Tubing..... 104-106
-  Heatshrink Caps..... 107-108
-  PVC Sleeving..... 109
-  Heat Resistant Sleeving..... 110



### CABLE MANAGEMENT

-  Spiral Wrap Binding..... 112
-  Expandable Cable Jacketing..... 112
-  Flexible Conduit..... 113-114

### CABLE JOINTING

-  LLFA® Tape..... 116-118
-  Cellpack Resin Cable Joint Kits. 119-137
-  Universal Termination Box..... 138
-  Heatshrink Joint Kits..... 139
-  Mechanical Connectors..... 140-143
-  Underground Marking Tape..... 144

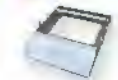
### CABLE HANDLING

-  Cable Drum Jacks & Rollers..... 146
-  Drum Rotators & Cable Dispensers.. 147
-  Cable Socks..... 148

### TOOLING





-  Tool Hire..... 151
-  Unior® Tools..... 152-153
-  Pressmaster® Tools..... 154-159
-  Crimp Tools For Pre-insulated Terminals..... 160-161
-  Calibration Gauges..... 160
-  Service Pliers..... 161
-  Crimp Tools For Un-insulated Terminals..... 162
-  Crimp Tools For Bootlace Ferrules..... 163-164
-  Large Hand Mechanical Crimp Tools.. 165
-  Hydraulic Crimp Tools..... 166
-  Hydraulic Crimp Heads..... 167
-  Hydraulic Foot Pumps..... 168

# CONTENTS 3

## TOOLING

	Battery Operated Crimp Tools & Cutters.....	168-169
	Electrical Crimping Unit.....	170
	Pneumatic Crimp Tool.....	170
	Cable Cutters.....	171-172
	Hydraulic Cable Cutters.....	172
	Wire Strippers, Mini Trunking Tools, Conduit Cutters.....	173
	Impact and Punch Down Tools.....	174
	Modular Crimping Tool Kit.....	174
	Cable Tie Tensioning Tools.....	175
	Hot Air Guns.....	175

## EARTHING COMPONENTS & ACCESSORIES

	Earthing Rod & Earth Rod Accessories.....	179
	Copper Alloy Clamps.....	180
	Earth Clamps.....	180
	Tape Clips and Clamps.....	181

## EARTHING COMPONENTS & ACCESSORIES

	Earth Bars & Disconnecting Links....	182
	Copper and Aluminium Tape.....	183
	Earthing Accessories.....	184-186

## TAPES, SEALANTS & LUBRICANTS

	LLFA® Tape.....	188-190
	PVC Electrical Tapes.....	191
	Self-Amalgamating Tape.....	192
	Denso Tape & Gaffer Tape.....	192
	Marking & Warning Tapes.....	193
	Sealing Compounds.....	194-195
	Cellpack Easy-Glide.....	196
	Hole Saws and Accessories.....	197

# CONTENTS 4

## CONTENTS 4

### INDUSTRIAL AEROSOL PRODUCTS



*Silicone Lubricant..... 200*



*Cold Zinc Galv Spray..... 200*



*Cutting & Tapping Spray..... 200*



*Clear Penetrating Oil..... 200*



*Electrical Cleaner.....201*



*Air Duster Spray.....201*



*Line Marking Paint.....201*

### SUNDRIES



*Brass Stud Extensions.....204*



*Long Metric Screws.....204*



*Constant Force Springs.....205*



*Hose Clamps.....205*

### DEFINITIONS

*Degree of Ingress Protection.....206*

*Hazardous Area Classifications.....207*

# CABLE TERMINATIONS

# CABLE TERMINATIONS

	<b>Pre-insulated Terminals.....</b>	<b>6-14</b>
	<b>Bootlace Ferrules.....</b>	<b>15-16</b>
	<b>Copper Tube Terminals.....</b>	<b>17-23</b>
	<b>Reduced Palm Heavy Duty Terminals.....</b>	<b>23</b>
	<b>Shear-Bolt Connectors.....</b>	<b>24</b>
	<b>Screw Connectors.....</b>	<b>140-143</b>
	<b>Copper Tube Splices.....</b>	<b>25</b>
	<b>Copper Pin Terminals.....</b>	<b>26</b>
	<b>Selekt-A-Box™.....</b>	<b>27-29</b>
	<b>Fix-A-Box™.....</b>	<b>30-31</b>
	<b>Terminal Kit Boxes.....</b>	<b>32</b>
	<b>Fixing Tubs.....</b>	<b>33</b>
	<b>Aluminium Terminals.....</b>	<b>33</b>
	<b>“Push-In” Wire Connectors.....</b>	<b>34</b>
	<b>Piano Key Connectors.....</b>	<b>34</b>
	<b>Terminal Strip Connectors.....</b>	<b>35</b>
	<b>Solar PV Terminals &amp; Tools.....</b>	<b>36-37</b>

# Pre-insulated Terminals

## Crimping Procedure for Pre-insulated Terminals

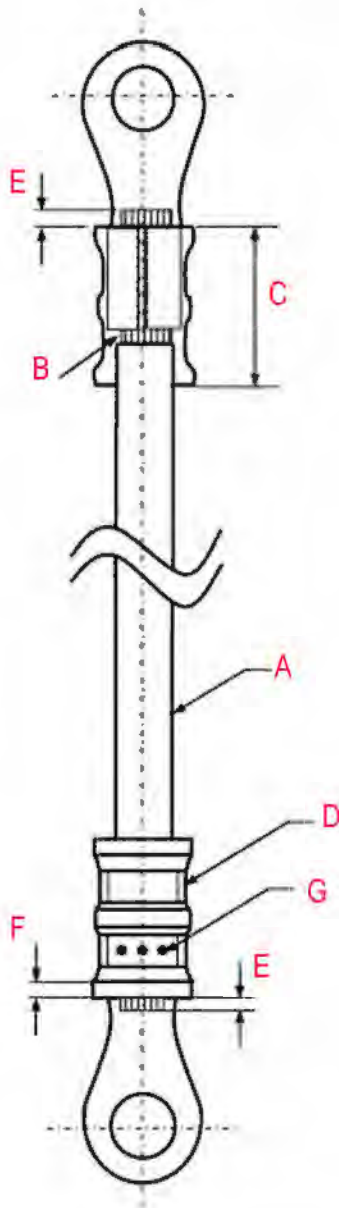

(A) Cut wire to length

(B) Strip the wire ends, ensuring the insulation is removed cleanly and square with the axis with no breaking or nicking of visible wire ends

(C) Use the recommended stripped length appropriate to the connector being used, ensuring all strands are inserted fully into the crimp barrel

(D) Ensure the selected crimp die is suitable for the correct combination of conductor and terminal being used

(E) Insert conductor, stripped, to a length that leaves approximately 1mm visible at front of barrel

(F) Position the die such as to leave approximately 1mm of barrel to form a bellmouth at the front of the barrel

(G) Check the correct dot code or die identification is being used

(H) Ensure the tool and dies are calibrated and maintained in a serviceable condition in line with the manufacturer's Operating Instructions



# Pre-insulated Terminals



## Ring Terminals

**Material:** Copper  
**Insulation:** Polyvinyl Chloride  
**Max. elec. rating:** ■ 19 amp  
 ■ 27 amp  
 ■ 48 amp

600 volts 75°C

RoHS compliant

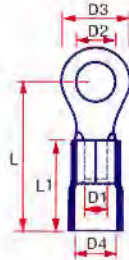

Wire Range mm <sup>2</sup> (AWG)	Part No.	Dimensions mm					
		D1	D3	D4	L	L1	D2
0.5-1.5 (22 - 16)	32RER	1.8	5.5	4.3	13.7	10	3.2
	37RER	1.8	6.6	4.3	15.5	10	3.7
	43RER	1.8	8.0	4.3	16.2	10	4.3
	53RER	1.8	8.0	4.3	16.7	10	5.3
	65RER	1.8	11.0	4.3	20.4	10	6.5
1.5-2.5 (16 - 14)	85RER	1.8	12.0	4.3	20.2	10	8.5
	10RER	1.8	14.5	4.3	25.1	10	10.0
	32BER	2.3	5.5	4.8	15.5	10	3.2
	37BER	2.3	6.6	4.8	15.6	10	3.7
1.5-2.5 (16 - 14)	43BER	2.3	8.0	4.8	15.9	10	4.3
	53BER	2.3	8.0	4.8	16.9	10	5.3
	65BER	2.3	10.5	4.8	20.8	10	6.5
	85BER	2.3	12.0	4.8	21.4	10	8.5
	10BER	2.3	14.5	4.8	23.6	10	10.0
4-6 (12 - 10)	32YER	3.5	7.2	6.5	22.2	13.5	3.2
	37YER	3.5	7.2	6.5	22.2	13.5	3.7
	43YER	3.5	9.5	6.5	22.2	13.5	4.3
	53YER	3.5	9.5	6.5	22.2	13.5	5.3
	65YER	3.5	11.0	6.5	23.5	13.5	6.5
	85YER	3.5	14.0	6.5	27.0	13.5	8.5
10YER	3.5	15.0	6.5	30.0	13.5	10.0	
12YER	3.5	19.0	6.5	30.0	13.5	13.0	

Pack Quantity: 100

## Fork Terminals

**Material:** Copper  
**Insulation:** Polyvinyl Chloride  
**Max. elec. rating:** ■ 19 amp  
 ■ 27 amp  
 ■ 48 amp

600 volts 75°C

RoHS compliant

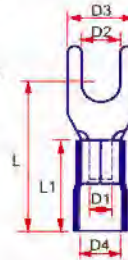

Wire Range mm <sup>2</sup> (AWG)	Part No.	Dimensions mm					
		D1	D3	D4	L	L1	D2
0.5-1.5 (22 - 16)	32RF	1.8	5.7	4.3	15.3	10	3.2
	37RF	1.8	6.4	4.3	15.3	10	3.7
	43RF	1.8	6.4	4.3	15.8	10	4.3
	53RF	1.8	7.5	4.3	16.4	10	5.3
	65RF	1.8	8.5	4.3	19.7	10	6.5
1.5-2.5 (16 - 14)	32BF	2.3	6.0	4.8	16.0	10	3.2
	37BF	2.3	6.4	4.8	15.7	10	3.7
	43BF	2.3	6.4	4.8	16.1	10	4.3
	53BF	2.3	8.5	4.8	16.2	10	5.3
4-6 (12 - 10)	65BF	2.3	11.0	4.8	20.1	10	6.5
	37YF	3.5	6.4	6.5	20.8	13.5	3.7
	43YF	3.5	7.1	6.5	21.0	13.5	4.3
4-6 (12 - 10)	53YF	3.5	9.5	6.5	21.6	13.5	5.3
	65YF	3.5	12.0	6.5	24.9	13.5	6.5

Pack Quantity: 100

Vibration resistant versions available on request  
 Non-insulated & Non-insulated High  
 Temperature Terminals available on request.

Pre-insulated Terminals



# Pre-insulated Terminals

## Blade Terminals

**Material:** Copper  
**Insulation:** Polyvinyl Chloride



**Max. elec. rating:** ■ 19 amp  
 ■ 27 amp  
 ■ 48 amp

RoHS compliant



600 volts 75°C



Wire Range mm <sup>2</sup> (AWG)	Part No.	Dimensions mm						
		D1	D3	L	L1	D2	H1	H2
	<b>10RB</b>	1.8	4.3	20.0	10.0	2.3	15.5	5.5
	<b>18RB</b>	1.8	4.3	28.0	10.0	2.5	23.5	5.5
	<b>9BB</b>	2.3	4.8	20.0	10.0	2.3	15.5	5.5
	<b>18BB</b>	2.3	4.8	28.0	10.0	2.5	23.5	5.5
	<b>10YB</b>	3.5	6.5	23.5	13.5	3.0	16.7	6.5
	<b>16YB</b>	3.5	6.5	29.5	13.5	4.8	22.5	6.5
	<b>18YB</b>	3.5	6.5	31.5	13.5	2.1	24.5	6.5

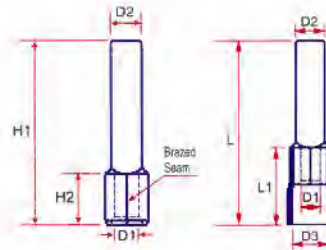

Pack Quantity: 100

## Pin Terminals

**Material:** Copper  
**Insulation:** Polyvinyl Chloride



**Max. elec. rating:** ■ 19 amp  
 ■ 27 amp  
 ■ 48 amp

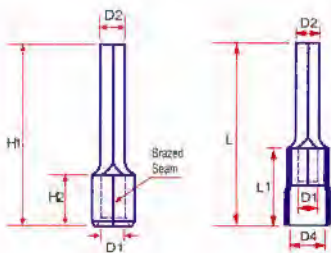

RoHS compliant

600 volts 75°C



Wire Range mm <sup>2</sup> (AWG)	Part No.	Dimensions mm						
		D1	D4	L	L1	D2	H1	H2
	<b>95RP</b>	1.8	4.3	19.0	10.0	1.9	14.6	5.5
	<b>12RP</b>	1.8	4.3	22.0	10.0	1.9	17.8	5.5
	<b>95BP</b>	2.3	4.7	19.0	10.0	1.9	14.6	5.5
	<b>12BP</b>	2.3	4.7	22.0	10.0	1.9	17.6	5.5
	<b>14YP</b>	3.5	6.8	28.0	13.5	2.7	21.0	6.5
		4-6 (16 - 14)						

Pack Quantity: 100

Vibration resistant versions available on request.

Un-insulated & Un-insulated High Temperature Terminals available on request.

# Pre-insulated Terminals



## Hooked Blade



**Material:** Copper  
**Insulation:** Polyvinyl Chloride

**Max. elec. rating:** ■ 19 amp  
 ■ 27 amp  
 ■ 48 amp

RoHS compliant



600 volts 75°C

Wire Range mm <sup>2</sup> (AWG)	Part No.	Dimensions mm								
		D1	D2	D3	D4	L	L1	H1	H2	T
 0.5-1.5 (22 - 16)	30RHB	1.7	2.1	3.0	4.3	26.5	10.0	22.0	5.5	0.8
	46RHB	1.7	2.1	4.6	4.3	26.0	10.0	22.0	5.5	0.8
 1.5-2.5 (16 - 14)	30BHB	2.3	2.1	3.0	4.8	26.5	10.0	22.0	5.5	0.8
	46BHB	2.3	2.1	4.6	4.8	26.5	10.0	22.0	5.5	0.8
 4-6 (12 - 10)	30YHB	3.4	2.4	3.0	6.5	30.0	13.5	23.0	6.5	0.8
	46YHB	3.4	2.4	4.6	6.5	30.0	13.5	23.0	6.5	0.8

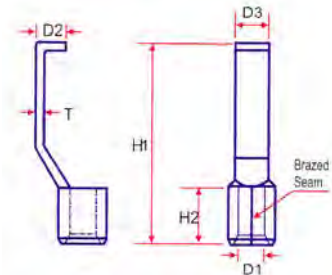

Pack Quantity: 100

Vibration resistant versions available on request.

# Pre-insulated Terminals

## Female Push-on

**Material:** Brass - Tin Plated  
**Insulation:** Polyvinyl Chloride  
 UL approval  
 RoHS compliant

**Max. elec. rating:** 10 amp  
 15 amp  
 24 amp

300 volts 75°C

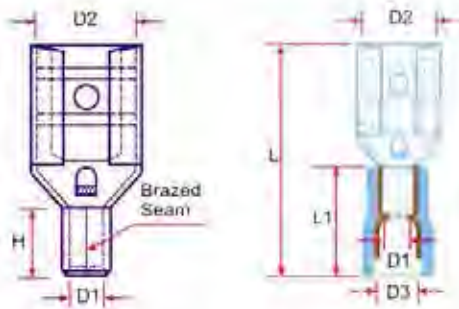

Un-insulated Female Push-on  
 Terminals available on request.



Wire Range mm <sup>2</sup> (AWG)	Part No.	Dimensions mm						
		D1	D2	D3	H	L	L1	Tab Size
1.8 (22 - 16)	28RFP	1.8	3.2	4.3	5.5	19.0	10.0	2.8 x 0.5
	28RFPX	1.8	3.5	4.3	5.5	19.0	10.0	2.8 x 0.8
	48RFP	1.8	5.5	4.3	5.5	19.0	10.0	4.8 x 0.5
	48RFPX	1.8	5.5	4.3	5.5	19.0	10.0	4.8 x 0.8
0.5-1.5 (22 - 16)	63RFP	1.8	6.6	4.3	5.5	20.5	10.0	6.3 x 0.8
	28BFP	2.3	4.8	4.8	5.5	13.8	10.0	2.8 x 0.5
2.3 (16 - 14)	28BFPX	2.3	4.8	4.8	5.5	14.3	10.0	2.8 x 0.8
	48BFP	2.3	5.5	4.8	5.5	19.0	10.0	4.8 x 0.5
	48BFPX	2.3	5.5	4.8	5.5	19.0	10.0	4.8 x 0.8
1.5-2.5 (16 - 14)	63BFP	2.3	6.6	4.8	5.5	20.5	10.0	6.3 x 0.8
	63YFP	3.5	6.6	6.6	6.5	24.6	13.5	6.3 x 0.8
4-6 (12 - 10)	95YFP	3.5	10.0	6.6	6.5	24.6	13.7	9.5 x 1.2

Pack Quantity: 100

## Male Push-on

**Material:** Brass - Tin Plated  
**Insulation:** Polyvinyl Chloride

RoHS compliant



**Max. elec. rating:** 10 amp  
 15 amp  
 24 amp

300 volts 75°C

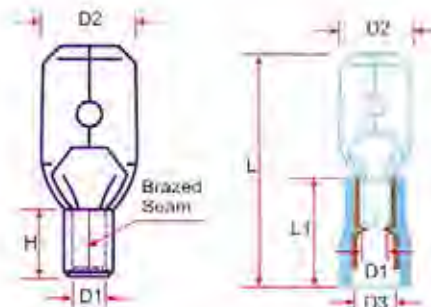

Un-insulated Male Push-on Terminals  
 available on request.



Wire Range mm <sup>2</sup> (AWG)	Part No.	Dimensions mm						
		D1	D2	D3	H	L	L1	Tab Size
1.8 (22 - 16)	28RMP	1.8	2.8	4.3	5.5	19.6	10.0	2.8 x 0.5
	48RMP	1.8	4.8	4.3	5.5	19.6	10.0	4.8 x 0.5
0.5-1.5 (22 - 16)	63RMP	1.8	6.3	4.3	5.5	21.0	10.0	6.3 x 0.8
	48BMP	2.3	4.8	4.8	5.5	13.8	10.0	4.8 x 0.5
1.5-2.5 (16 - 14)	63BMP	2.3	6.3	4.8	5.5	16.2	10.0	6.3 x 0.8
	63YMP	3.5	6.3	6.6	6.5	25.0	13.4	6.3 x 0.8
4-6 (12 - 10)								

Pack Quantity: 100

# Pre-insulated Terminals



## Fully Insulated Female Push-on

Wire Range mm <sup>2</sup> (AWG)	Part No.	Dimensions mm							Tab Size
		D1	D2	D3	H	L	L1		
28-48	28RFPT	1.8	3.2	4.3	5.5	20.0	10.0	2.8 x 0.5	
	28RFPTX	1.8	3.5	4.3	5.5	20.0	10.0	2.8 x 0.8	
	48RFPT	1.8	5.5	4.3	5.5	20.0	10.0	4.8 x 0.5	
0.5-1.5 (22 - 16)	48RFPTX	1.8	5.5	4.3	5.5	20.0	10.0	4.8 x 0.8	
	63RFPT	1.8	6.6	4.3	5.5	21.5	10.5	6.3 x 0.8	
1.5-2.5 (16 - 14)	48BFPT	2.3	5.0	4.8	5.5	20.0	10.0	4.8 X 0.5	
	48BFPTX	2.3	5.0	4.8	5.5	20.0	10.0	4.8 X 0.8	
	63BFPT	2.3	6.6	4.8	5.5	21.5	10.5	6.3 X 0.8	
4-6 (12 - 10)	63YFPT	3.5	6.6	6.0	6.5	23.5	13.7	6.3 X 0.8	
	95YFPT	3.5	10.0	6.0	6.5	30.0	13.7	9.5 X 1.2	

Pack Quantity: 100

Max. elec. rating: ■ 10 amp ■ 15 amp ■ 24 amp  
 300 volts 75°C

Material: Brass - Tin Plated  
 Insulation: Polyvinyl Chloride



RoHS compliant

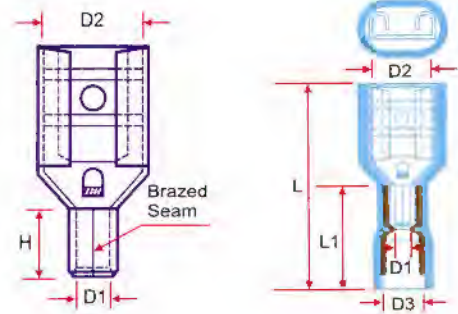

## Flag Female Push-on

Material: Brass - Tin Plated  
 Insulation: Nylon  
 Max. elec. rating: 300 volts 75°C

RoHS compliant



Part No.	mm <sup>2</sup>	Tab Size	Amp Rating
63RFPT/RA	0.5-1.5	6.3 x 0.8	10
63BFPT/RA	1.5-2.5	6.3 x 0.8	15

Pack Quantity: 100



Pre-insulated Terminals

# Pre-insulated Terminals

## Butt & Parallel Splices



Material: Copper  
Insulation: Polyvinyl Chloride

Max. elec. rating: ■ 19 amp  
■ 27 amp  
■ 48 amp

RoHS compliant



600 volts 75°C

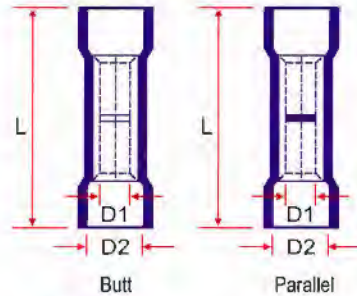

### Butt

Wire Range mm <sup>2</sup> (AWG)	Part No.	Dimensions mm		
		D1	D2	L
0.5-1.5 (22 - 16)	15BSL	1.8	4.3	24.5
1.5-2.5 (16 - 14)	25BSL	2.3	4.8	24.5
4-6 (12 - 10)	6BSL	3.5	6.6	26.0

### Parallel

Wire Range mm <sup>2</sup> (AWG)	Part No.	Dimensions mm		
		D1	D2	L
0.25-1.65 (22 - 16)	15PSL	1.7	3.3	16.0
1.04-2.63 (16 - 14)	25PSL	2.3	4.0	16.0
4-6 (12 - 10)	6PSL	3.4	5.5	20.5

Pack Quantity: 100

Vibration resistant versions available on request.

Pack Quantity: 100

## Piggy Back - Push On

Material: Brass - Tin Plated  
Insulation: Polyvinyl Chloride

Max. elec. rating: ■ 10 amp  
■ 15 amp  
■ 24 amp

RoHS compliant



300 volts 75°C



Wire Range mm <sup>2</sup> (AWG)	Part No.	Dimensions mm								
		D1	D2	D3	D4	L	L1	L2	H	Tab Size
0.5-1.5 (22 - 16)	63RPIG	1.8	6.6	8.0	4.3	20.0	10.0	7.5	5.5	6.3 x 0.8
1.5-2.5 (16 - 14)	63BPIG	2.3	6.6	8.0	4.8	20.0	10.0	7.5	5.5	6.3 x 0.8
4-6 (12 - 10)	63YPIG	3.5	6.6	8.0	6.5	24.0	13.5	7.5	6.5	6.3 x 0.8

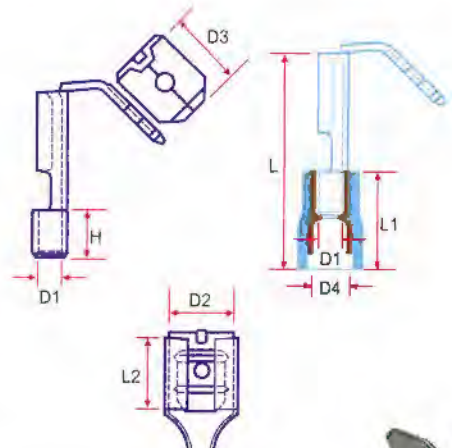

Pack Quantity: 100

Un-insulated Piggy Back  
Terminals available on  
request.



# Pre-insulated Terminals

## Heatshrink Butt Splice Connectors

**Material:** Copper, Tubular  
**Insulation:** High density PE

**Max. elec. rating:** 600 volts  
**Shrink temp:** 150°C

**Max. elec. rating** ■ 19 amp ■ 27 amp ■ 48 amp

**Resistant temp:** -10°C to +105°C

Part No.	Wire Range		Dimensions mm	
	mm <sup>2</sup>	AWG	L	D1
15BSL/HS	0.5-1.5	22-16	35	1.8
25BSL/HS	1.5-2.5	16-14	35	2.3
6BSL/HS	4.0-6.0	12-10	42	3.5

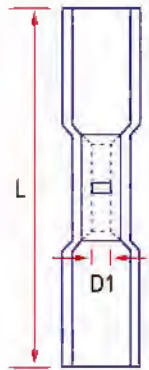

Pack Quantity: 100

## End Splices

**Material:** Copper  
**Insulation:** Nylon 6/6

**Insulation Colour:** Neutral  
**Max. elec. rating:** 600 volts 75°C

RoHS compliant



Part No.	Dimensions (mm)						Amp Rating
	mm <sup>2</sup>	AWG	L1	L2	W	H	
15NES	0.5-1.5	22-16	18.0	12.0	4.75	6.55	19
25NES	1.5-2.5	16-14	21.0	15.0	5.40	6.80	27
6NES	4.0-6.0	12-10	25.0	15.5	7.22	8.00	48

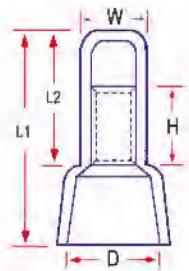

Pack Quantity: 100

## Snap Connectors

Snap-connectors provide quick, reliable connections with a quick snap and squeeze.

- No special tools needed – no cable stripping required simply squeeze and snap-fit
- Colour coded for easy identification
- A dependable and reliable electrical connection

Part No.	Dimensions (mm)			
	mm <sup>2</sup>	AWG	W	L
SC1.5	0.5-1.0	22-18	19.0	29.0
SC2.5	0.75-2.5	18-14	19.0	29.0
SC6	4.0-6.0	12-10	19.0	34.0



SC1.5

SC2.5

SC6

**Material:** Brass, Tin Plated **Insulation Material:** PP

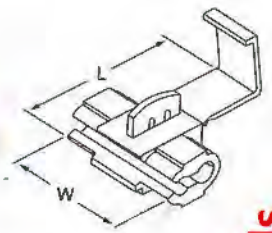

- 105°C 600 volts - 10 amps ■ 105°C 600 volts - 15 amps ■ 105°C 600 volts - 24 amps

Tap Nylon Insulated Self-Stripping connectors, used to electrically tap into a wire in mid-span without cutting or stripping the wire.

Part No.	Dimensions (mm)			
	mm <sup>2</sup>	AWG	W	L
SC1.5/TAP	0.5-1.0	22-18	10.0	38.0
SC2.5/TAP	0.75-2.5	18-14	10.0	38.0
SC6/TAP	4.0-6.0	12-10	10.0	39.0



SC1.5/TAP

SC2.5/TAP

SC6/TAP

**Material:** Brass, Tin Plated **Insulation Material:** PP

- 105°C 600 volts - 10 amps ■ 105°C 600 volts - 27 amps ■ 105°C 600 volts - 48 amps

Pack Quantity: 100



TEL: (44) 01453 844333 | FAX: (44) 01453 842224 | E-MAIL: sales@swaonline.co.uk

# Pre-insulated Terminals

## Bullets (Male/Female)



Male

Female

**Material:** Brass-Tin Plated  
**Insulation:** Polyvinyl Chloride

**Max. elec. rating:** ■ 10 amp  
 ■ 15 amp  
 ■ 24 amp  
 300 volts 75°C

RoHS compliant

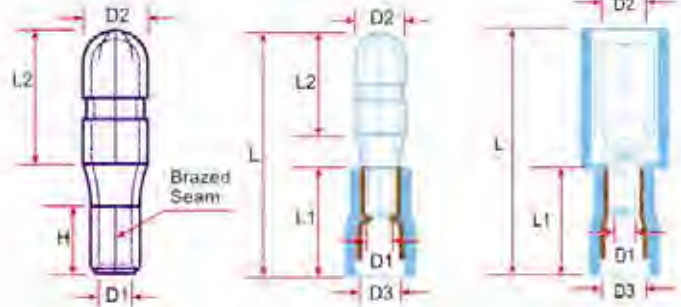

### Male

Wire Range mm <sup>2</sup> (AWG)	Part No.	Dimensions mm						
		D1	D2	D3	L	L1	L2	H
0.5-1.5 (22 - 16)	4RBM	1.8	4.0	4.3	20.7	10.0	8.5	5.5
1.5-2.5 (16 - 14)	4BBM	2.3	4.0	4.8	20.5	10.0	8.5	5.5
	50BBM	2.8	5.0	4.8	21.0	10.0	8.5	5.5
4-6 (12 - 10)	50YBM	3.5	5.0	6.6	25.0	13.5	8.5	6.5

Pack Quantity: 100

### Female

Wire Range mm <sup>2</sup> (AWG)	Part No.	Dimensions mm						
		D1	D2	D3	L	L1	L2	H
0.5-1.5 (22 - 16)	4RSF	1.8	4.0	4.3	23.6	10.5	7.3	5.5
1.5-2.5 (16 - 14)	4BSF	2.3	4.0	4.3	23.6	11.5	7.3	5.5
	50BSF	2.3	5.0	4.8	23.6	11.5	7.0	5.5
4-6 (12 - 10)	50YSF	3.5	5.0	6.5	26.7	13.8	7.0	6.5

Pack Quantity: 100

## Modular Plugs and Plug Covers



Part No.	Description
RJ45-8A2	Modular Plug (stranded wire)
RJ45-8A3	Modular Plug (stranded wire or solid wire)
RJ45-60GY	Grey Plug Cover
RJ45-60R	Red Plug Cover
RJ45-60Y	Yellow Plug Cover
RJ45-60BL	Blue Plug Cover

Pack Quantity: 100

Tools to crimp modular plugs and plug covers:

- Pressmaster 4300-3149 tool frame & RJ45 4300-3144 (see pages 155 & 157)
- MCK (see page 174)
- MCT (see page 174)
- IPDT-KR (see page 174)





# Bootlace Ferrules



## Insulated Bootlace Ferrules

**Material:** Electrolytic Copper - purity grade 99.9%

**Insulation:** Polyamide 66

RoHS compliant



Resistance to external agents - good resistance to bases and weak acids. Limited resistance to strong oxidising acids, oil and mineral oils. Not resistant to chlorinated solvents.

**Polypropylene**

Humidity absorption: 0

Working Temperature: -40°C to +105°C

During installation: From 0°C to +60°C

Max. admissible point: +120°C for short periods

Melting point: +165°C

Limit oxygen index (LOI): 17%

Voltage: Max 300V

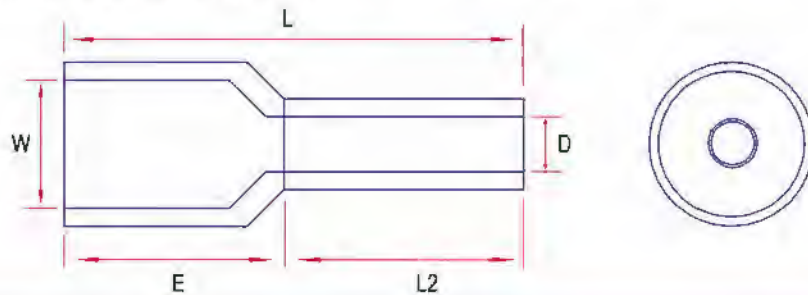

French T-Range Part No.	Colour	German K-Range Part No.	Colour	mm <sup>2</sup>	Dimensions mm				
					L	W	E	D	L2
0.25-8IBLF/T	White	N/A	N/A	0.25	12.4	1.8	4.0	0.8	8.0
0.3-6IBLF/T	Pink	0.3-6IBLF/K	Turquoise	0.30	10.4	2.0	4.0	0.8	6.0
0.50-8IBLF/T	White	0.50-8IBLF/K	Orange	0.50	14.0	2.6	6.0	1.0	8.0
0.75-8IBLF/T	Blue	0.75-8IBLF/K	White	0.75	14.0	2.8	6.0	1.2	8.0
1.0-8IBLF/T	Red	1.0-8IBLF/K	Yellow	1.00	14.0	3.0	6.0	1.4	8.0
1.5-8IBLF/T	Black	1.5-8IBLF/K	Red	1.50	14.0	3.5	6.0	1.7	8.0
2.5-8IBLF/T	Grey	2.5-8IBLF/K	Blue	2.50	14.0	4.2	6.0	2.2	8.0
2.5-18IBLF/T	Grey	2.5-18IBLF/K	Blue	2.50	14.0	4.2	6.0	2.2	18.0
4.0-9IBLF/T	Orange	4.0-9IBLF/K	Grey	4.00	16.5	4.8	8.0	2.8	9.0
4.0-18IBLF/T	Orange	4.0-18IBLF/K	Grey	4.00	25.5	4.8	8.0	2.8	18.0
6.0-12IBLF/T	Green	6.0-12IBLF/K	Black	6.00	20.0	6.3	8.0	3.5	12.0
6.0-18IBLF/T	Green	6.0-18IBLF/K	Black	6.00	26.0	6.3	8.0	3.5	18.0
10-12IBLF/T	Brown	10-12IBLF/K	Ivory	10	22.0	7.6	10.0	4.5	12.0
10-18IBLF/T	Brown	10-18IBLF/K	Ivory	10	28.0	7.6	10.0	4.5	18.0
16-12IBLF/T	Ivory	16-12IBLF/K	Green	16	24.0	8.8	12.0	5.8	12.0
16-18IBLF/T	Ivory	16-18IBLF/K	Green	16	30.0	8.8	12.0	5.8	18.0
25-16IBLF/T	Black	25-16IBLF/K	Brown	25	28.0	11.2	12.0	7.3	16.0
35-25IBLF/T	Red	35-25IBLF/K	Beige	35	39.0	12.7	14.0	8.3	25.0
50-20IBLF/T	Blue	50-20IBLF/K	Olive	50	36.0	15.0	16.0	10.3	20.0

Pack Quantity: 100

Larger sizes available on request.

See pages 163 and 164 for recommended tooling.

Bootlace Ferrules



TEL: (44) 01453 844333 | FAX: (44) 01453 842224 | E-MAIL: sales@swaonline.co.uk

## Bootlace Ferrules



### Insulated Bootlace Ferrules - Twin Entry

Part No.	mm <sup>2</sup>	Colour	Dimensions mm				
			L	D1	D2	D3	L2
0.50-8IBLF/2	0.50	White	15.0	1.50	2.5	4.7	8.0
0.75-8IBLF/2	0.75	Grey	15.0	1.80	2.8	5.0	8.0
1.0-8IBLF/2	1.00	Red	15.0	2.05	3.4	5.4	8.0
1.5-8IBLF/2	1.50	Black	16.0	2.30	3.6	6.6	8.0
2.5-8IBLF/2	2.50	Blue	18.5	2.80	4.2	7.8	10.0
4.0-9IBLF/2	4.00	Grey	23.0	3.70	4.9	8.8	12.0
6.0-14IBLF/2	6.00	Yellow	26.0	4.80	6.9	10.0	14.0
10-14IBLF/2	10	Red	26.0	6.40	7.2	13.0	14.0
16-14IBLF/2	16	Blue	30.0	8.30	9.6	18.4	14.0

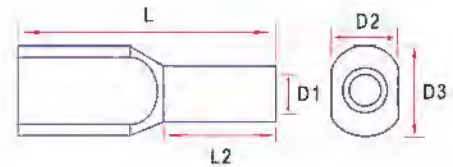

Pack Quantity: 100 Voltage: Max 300V

Approval:



### Uninsulated Bootlace Ferrules

Part No.	mm <sup>2</sup>	Dimensions mm		
		D1	D2	L
0.50-10UBLF	0.50	1.0	2.1	10.0
0.75-8UBLF	0.75	1.2	2.3	8.0
1.0-8UBLF	1.00	1.4	2.5	8.0
1.0-10UBLF	1.00	1.4	2.5	10.0
1.5-8UBLF	1.50	1.7	2.8	8.0
1.5-10UBLF	1.50	1.7	2.8	10.0
2.5-10UBLF	2.50	2.2	3.4	10.0
4.0-9UBLF	4.00	2.8	4.0	9.0
6.0-15UBLF	6.00	3.5	4.7	15.0
10-15UBLF	10	4.5	5.8	15.0
16-15UBLF	16	5.8	7.5	15.0
25-18UBLF	25	7.3	9.5	18.0
35-18UBLF	35	8.3	11.0	18.0
50-25UBLF	50	10.3	13.0	25.0



Pack Quantity: 100 Voltage: Max 300V

See pages 163 and 164 for recommended tooling.

# Copper Tube Terminals

## Cable Preparation

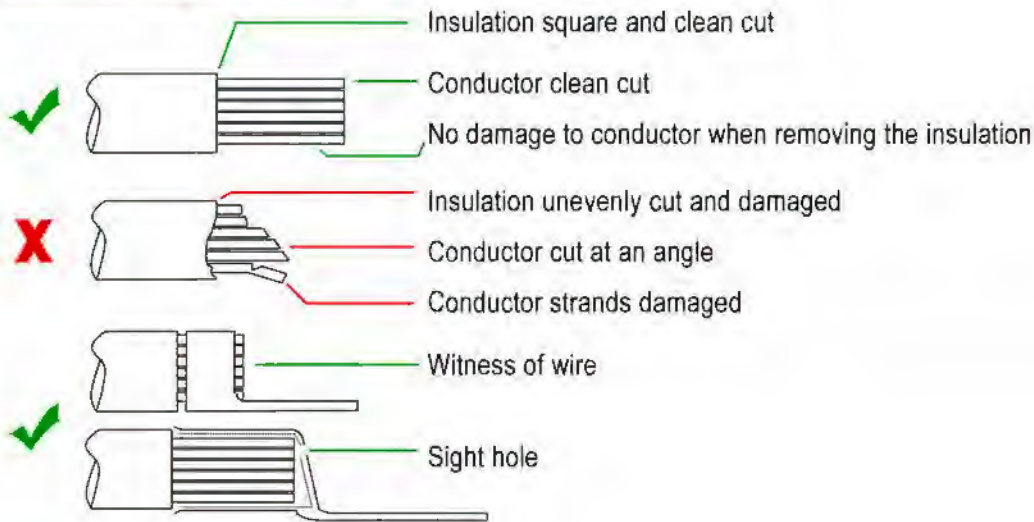

## Correct Compression Techniques

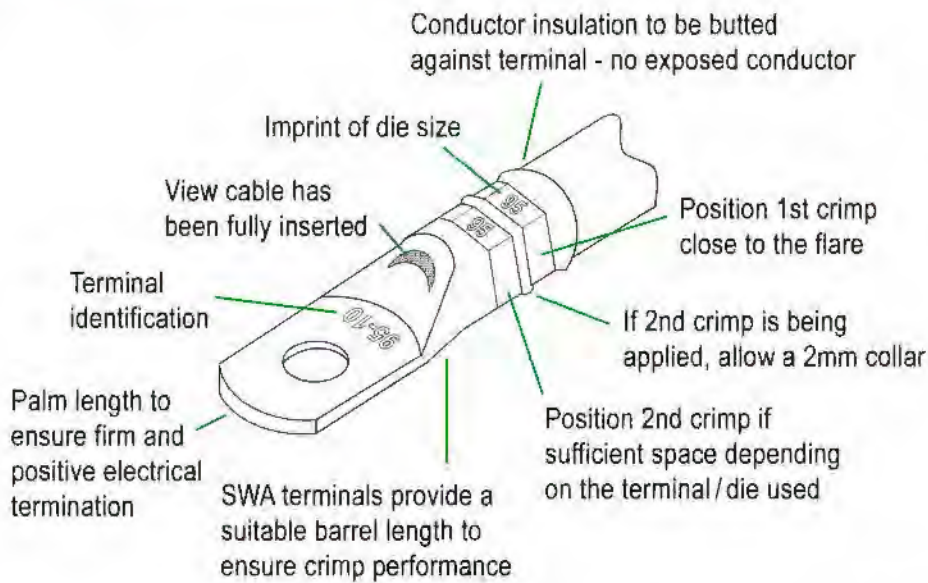

All tooling used in the application of cable connectors should be kept in a good state of repair, regularly maintained and used in strict accordance with the manufacturer's operating instructions

## Common Compression Faults

This joint is very unsafe. It is unlikely that the conductor is more than superficially compressed



# Copper Tube Terminals



## TQ Range

**Application:** Un-insulated heavy duty terminals suitable for power cables up to 1000 volts.

**Material:** Manufactured from seamless copper tube to BS EN 12449:2012

**Finish:** Electro Tin plated to BS 1872:1974

- Tensile performance requirements to BS 61238-1 : 2003
- All terminals are manufactured from 99.5% copper and double annealed to ensure optimum ductility to avoid severe deformation such as cracking and splitting when crimped
- Terminals are supplied with an inspection window which enables the user to ensure full and correct insertion of the conductor and a flared entry ensures a smooth transition from terminal to conductor
- Internal barrel diameters suit standard cables as defined in BS 6360
- All SWA terminals are identified on the palm with cable size (and stud hole size) to ensure correct selection of the appropriate tool and dies

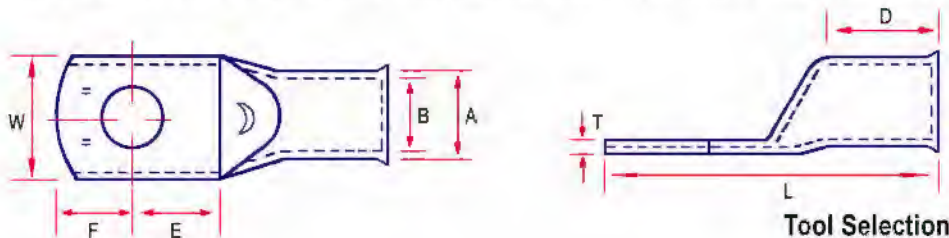

Tool Selection

Cond. Size mm <sup>2</sup> Strand / Flex.	Part No.	Pack Qty	Stud Hole	Dimensions mm								Supplied With Dies						
				A	B	W	E	F	D	L	T	Crimp Profile	Y	Y	Y	Y		
1.5 / 1.5	1.5-4TQ	100	M4	3.3	1.8	8.5	6.0	6.0	6.0	6.0	18.0	0.8						
	1.5-5TQ	100	M5	3.3	1.8	9.5	6.0	6.0	6.0	6.0	20.0	0.8						
	1.5-6TQ	100	M6	3.3	1.8	10.5	6.0	6.0	6.0	6.0	20.0	0.8						
2.5 / 2.5	2.5-4TQ	100	M4	4.2	2.4	8.5	6.0	6.0	6.0	7.0	19.0	1.0						
	2.5-5TQ	100	M5	4.2	2.4	9.5	6.0	6.0	6.0	7.0	21.0	1.0						
	2.5-6TQ	100	M6	4.2	2.4	10.5	6.0	6.0	6.0	7.0	21.0	0.8						
4 / 4	4-4TQ	100	M4	5.0	3.0	8.5	6.0	5.5	9.0	25.0	1.3							
	4-5TQ	100	M5	5.0	3.0	9.5	6.0	6.0	9.0	25.0	1.1							
	4-6TQ	100	M6	5.0	3.0	10.5	9.5	6.0	9.0	25.0	1.0							
	4-8TQ	100	M8	5.0	3.5	12.0	9.5	9.5	9.0	33.0	1.0							
	4-10TQ	100	M10	5.0	3.5	14.0	9.5	9.5	9.0	33.0	1.0							
6 / 6	6-4TQ	100	M4	6.0	4.0	8.0	6.0	6.0	9.0	28.0	1.6							
	6-5TQ	100	M5	6.0	4.0	9.0	6.0	6.0	9.0	28.0	1.6							
	6-6TQ	100	M6	6.0	4.0	11.0	6.0	6.0	9.0	28.0	1.4							
	6-8TQ	100	M8	6.0	4.0	13.0	9.5	9.5	10.0	35.0	1.1							
	6-10TQ	100	M10	6.0	4.0	14.5	9.5	9.5	10.0	35.0	1.0							

### Mechanical Crimp Tools

Y	Y	Y	Y
✓	✓	●	●

RP1516

RP625

CT650H

CT6120H

Blank Palm and Angle Terminals available on request.

# Copper Tube Terminals

## Tool Selection

### TQ Range

Cond. Size mm <sup>2</sup> Strand / Flex.	Part No.	Pack Qty	Stud Hole	Dimensions mm								Supplied With Dies Crimp Profile.	Mechanical Crimp Tools						Hydraulic Crimp Tools					
				A	B	W	E	F	D	L	T		Y	Y	Y	Y	Y	Y	Y	Y	Y	Y	N	N
10 / 10	10-5TQ	50	M5	6.9	4.4	11.0	5.9	5.1	9.0	27.0	2.0	RP1516	RP16											
	10-6TQ	50	M6	6.9	4.4	11.0	5.9	5.1	9.0	27.0	2.0													
	10-8TQ	50	M8	6.9	4.4	14.0	9.75	8.25	11.0	35.0	1.6													
	10-10TQ	50	M10	6.9	4.4	6.0	12.0	10.0	10.0	39.0	1.5													
	10-12TQ	50	M12	6.9	4.4	18.0	12.0	10.0	10.0	39.0	1.3													
16 / 16	16-5TQ	10	M5	8.0	5.6	11.0	5.9	5.1	11.0	29.5	2.2	RP625	CT650H	CT6120H	CT1095I	CT10240I	CT16120H	RT10150H	HH10150H	HHI-10150	HHI-10400	HH10400H	HCH10400 (requires foot pump)	HCH10630 (requires foot pump)
	16-6TQ	10	M6	8.0	5.6	11.0	5.9	5.1	11.0	29.5	2.2													
	16-8TQ	10	M8	8.0	5.6	14.0	9.75	8.25	11.0	38.0	1.7													
	16-10TQ	10	M10	8.0	5.6	16.0	12.0	10.0	11.0	42.0	1.5													
	16-12TQ	10	M12	8.0	5.6	18.0	12.0	10.0	11.0	42.0	1.3													
	25 / 25	25-5TQ	10	M5	9.5	7.0	13.5	9.75	8.25	13.0	40.0													
25-6TQ	10	M6	9.5	7.0	13.5	9.75	8.25	13.0	40.0	2.4														
25-8TQ	10	M8	9.5	7.0	13.5	9.75	8.25	13.0	40.0	2.4														
25-10TQ	10	M10	9.5	7.0	16.0	12.0	10.0	13.0	44.0	2.0														
25-12TQ	10	M12	9.5	7.0	18.0	12.0	10.0	13.0	44.0	1.8														

Cond. Size mm <sup>2</sup> Strand / Flex.	Part No.	Pack Qty	Stud Hole	Dimensions mm								Supplied With Dies Crimp Profile.	Mechanical Crimp Tools						Hydraulic Crimp Tools					
				A	B	W	E	F	D	L	T		Y	Y	Y	Y	Y	Y	Y	Y	N	N	N	
35 / 35	35-6TQ	10	M6	11.0	8.2	15.5	9.75	8.25	14.0	41.0	2.8	CT650H	CT6120H	CT1095I	CT10240I									
	35-8TQ	10	M8	11.0	8.2	15.5	9.75	8.25	14.0	41.0	2.8													
	35-10TQ	10	M10	11.0	8.2	15.5	12.0	10.0	14.0	45.0	2.8													
	35-12TQ	10	M12	11.0	8.2	18.0	12.0	10.0	14.0	45.0	2.2													
	35-14TQ	10	M14	11.0	8.2	20.0	12.0	10.0	14.0	45.0	2.0													
	35-16TQ	10	M16	11.0	8.2	20.0	12.0	10.0	14.0	45.0	2.0													
50 / 50	50-6TQ	10	M6	12.1	9.45	17.2	9.75	8.25	18.0	46.0	4	CT16120H	CT25150H	RT10150H	HH10150H	HHI-10150	HHI-10400	HH10400H	HCH10400 (requires foot pump)	HCH10630 (requires foot pump)				
	50-8TQ	10	M8	12.1	9.45	17.2	9.75	8.25	18.0	46.0	2.4													
	50-10TQ	10	M10	12.1	9.45	17.2	12.0	10.0	18.0	50.0	2.4													
	50-12TQ	10	M12	12.1	9.45	17.2	12.0	10.0	18.0	50.0	2.4													
	50-14TQ	10	M14	12.1	9.45	20.0	15.0	12.0	18.0	55.0	1.9													
	50-16TQ	10	M16	12.1	9.45	22.0	15.0	12.0	18.0	55.0	1.7													
70 / 70	70-6TQ	10	M6	15.0	11.5	21.2	9.75	8.25	18.0	48.0	3.5													
	70-8TQ	10	M8	15.0	11.5	21.2	9.75	8.25	18.0	48.0	3.5													
	70-10TQ	10	M10	15.0	11.5	21.2	12.0	10.0	18.0	52.0	3.5													
	70-12TQ	10	M12	15.0	11.5	21.2	12.0	10.0	18.0	52.0	3.5													
	70-14TQ	10	M14	15.0	11.5	21.2	16.5	16.5	18.0	63.0	3.5													
	70-16TQ	10	M16	15.0	11.5	21.2	16.5	16.5	18.0	63.0	3.5													

Blank Palm and Angle Terminals available on request.



# Copper Tube Terminals

## TQ Range

## Tool Selection

Cond. Size mm <sup>2</sup> Strand / Flex.	Part No.	Pack Qty	Stud Hole	Dimensions mm								Supplied With Dies Crimp Profile	Mechanical Crimp Tools										Hydraulic Crimp Tools						
				A	B	W	E	F	D	L	T		Y	Y	Y	Y	Y	Y	Y	Y	Y	Y	Y	N	N				
95 / 95	95-6TQ	10	M6	17.0	13.5	24.3	12.0	10.0	24.0	58.0	3.5	CT1095i																	
	95-8TQ	10	M8	17.0	3.5	24.3	12.0	10.0	24.0	58.0	3.5																		
	95-10TQ	10	M10	17.0	13.5	24.3	12.0	10.0	24.0	58.0	3.5																		
	95-12TQ	10	M12	17.0	13.5	24.3	12.0	10.0	24.0	52.0	3.5																		
	95-14TQ	10	M14	17.0	13.5	21.2	12.0	10.0	24.0	52.0	3.5																		
	95-16TQ	10	M16	17.0	13.5	21.2	12.0	10.0	24.0	52.0	3.5																		
120 / 120	120-8TQ	10	M8	19.0	15.0	27.2	6.5	16.5	27.0	73.0	4.0	CT16120H	CT16120H	CT10240H	CT10240i														
	120-10TQ	10	M10	19.0	15.0	27.2	16.5	16.5	27.0	73.0	4.0																		
	120-12TQ	10	M12	19.0	15.0	27.2	16.5	16.5	27.0	73.0	4.0																		
	120-14TQ	10	M14	19.0	15.0	27.2	16.5	16.5	27.0	73.0	4.0																		
	120-16TQ	10	M16	19.0	15.0	27.2	16.5	16.5	27.0	73.0	4.0																		
	120-20TQ	10	M20	19.0	15.0	27.2	16.5	18.5	27.0	75.0	4.0																		
150 / 150	150-8TQ	10	M8	21.0	16.5	30.0	16.5	16.5	27.0	78.0	4.5																		
	150-10TQ	10	M10	21.0	16.5	30.0	16.5	16.5	27.0	78.0	4.5																		
	150-12TQ	10	M12	21.0	16.5	30.0	16.5	16.5	27.0	78.0	4.5																		
	150-14TQ	10	M14	21.0	16.5	30.0	16.5	16.5	27.0	78.0	4.5																		
	150-16TQ	10	M16	21.0	16.2	30.0	16.5	16.5	27.0	78.0	4.5																		
	150-20TQ	10	M20	21.0	16.5	30.0	8.75	14.25	27.0	78.0	4.5																		
185 / -	185-10TQ	10	M10	23.0	18.5	33.5	16.5	16.5	30.0	82.0	4.5																		
	185-12TQ	10	M12	23.0	18.5	33.5	16.5	16.5	30.0	82.0	4.5																		
	185-14TQ	10	M14	23.0	18.5	33.5	16.5	16.5	30.0	82.0	4.5																		
	185-16TQ	10	M16	23.0	18.5	33.5	16.5	16.5	30.0	82.0	4.5																		
	185-20TQ	10	M20	23.0	18.5	33.5	18.75	14.25	30.0	82.0	4.5																		
240 / -	240-10TQ	5	M10	26.0	21.0	37.7	18.0	17.0	32.0	88.0	5.0																		
	240-12TQ	5	M12	26.0	21.0	37.7	18.0	17.0	32.0	88.0	5.0																		
	240-14TQ	5	M14	26.0	21.0	37.7	18.0	17.0	32.0	88.0	5.0																		
	240-16TQ	5	M16	26.0	21.0	37.7	18.0	17.0	32.0	88.0	5.0																		
	240-20TQ	5	M20	26.0	21.0	37.7	8.0	17.0	32.0	88.0	5.0																		
300 / -	300-10TQ	5	M10	28.0	23.0	41.0	18.0	17.0	37.0	97.0	5.0																		
	300-12TQ	5	M12	28.0	23.0	41.0	18.0	17.0	37.0	97.0	5.0																		
	300-14TQ	5	M14	28.0	23.0	41.0	18.0	17.0	37.0	97.0	5.0																		
	300-16TQ	5	M16	28.0	23.0	41.0	18.0	17.0	37.0	97.0	5.0																		
	300-20TQ	5	M20	28.0	23.0	41.0	18.0	17.0	37.0	97.0	5.0																		

Blank Palm and Angle Terminals available on request.

# Copper Tube Terminals

## TQ Range

Cond. Size mm <sup>2</sup> Strand / Flex.	Part No.	Pack Qty	Stud Hole	Dimensions mm								Supplied With Dies Crimp Profile	Tool Selection Hydraulic Crimp Tools				
				A	B	W	E	F	D	L	T		Y	N	N	N	
400 / -	400-10TQ	5	M10	32.0	27.0	47.3	25.0	25.0	38.0	113.0	5.0						
	400-12TQ	5	M12	32.0	27.0	47.3	25.0	25.0	38.0	113.0	5.0						
	400-14TQ	5	M14	32.0	27.0	47.3	25.0	25.0	38.0	113.0	5.0						
	400-16TQ	5	M16	32.0	27.0	47.3	25.0	25.0	38.0	113.0	5.0						
	400-20TQ	5	M20	32.0	27.0	47.3	25.0	25.0	38.0	113.0	5.0						
500 / -	500-12TQ	2	M12	38.1	30.0	55.0	29.0	25.0	44.0	127.0	8.2						
	500-14TQ	2	M14	38.1	30.0	55.0	29.0	25.0	44.0	127.0	8.2						
	500-16TQ	2	M16	38.1	30.0	55.0	29.0	25.0	44.0	127.0	8.2						
	500-20TQ	2	M20	38.1	30.0	55.0	29.0	25.0	44.0	127.0	8.2						
630 / -	630-12TQ	2	M12	44.0	33.8	63.0	25.0	23.0	46.0	127.0	10.2						
	630-14TQ	2	M14	44.0	33.8	63.0	25.0	23.0	46.0	127.0	10.2						
	630-16TQ	2	M16	44.0	33.8	63.0	25.0	23.0	46.0	127.0	10.2						
	630-20TQ	2	M20	44.0	33.8	63.0	25.0	23.0	46.0	127.0	10.2						
800 / -	800-*TQ	2	Any	49.0	38.0	70.0	34.0	34.0	56.0	164.0	11.0	POA					
1000 / -	1000-*TQ	2	Any	53.0	42.5	77.0	34.0	34.0	56.0	169.0	10.5	POA					

\* = Denotes Stud Hole Size

Blank Palm and Angle Terminals available on request.

# Copper Tube Terminals

## 4 Hole Transformer Fixing Terminals

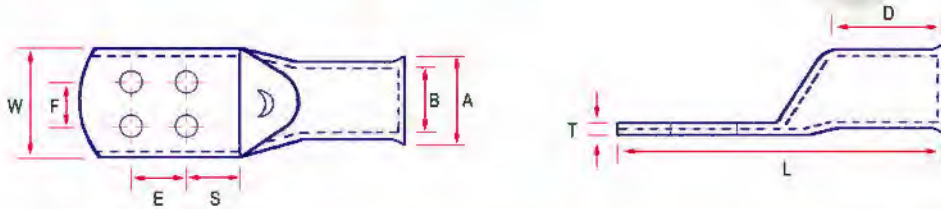

Part No.		Cable Size mm <sup>2</sup>	Dimensions mm									
8mm stud hole	10mm stud hole		A	B	W	E	F	D	L	S	T	
120-4 x 8TQ	120-4 x 10TQ	120	22.0	15.0	56.0	25.0	35.0	34.0	119.0	17.0	4.0	
150-4 x 8TQ	150-4 x 10TQ	150	23.0	16.5	56.0	25.0	35.0	34.0	119.0	17.0	4.5	
185-4 x 8TQ	185-4 x 10TQ	185	24.8	18.5	56.0	25.0	35.0	34.0	119.0	17.0	4.5	
240-4 x 8TQ	240-4 x 10TQ	240	28.0	21.0	56.0	25.0	35.0	34.0	119.0	17.0	5.0	
300-4 x 8TQ	300-4 x 10TQ	300	33.0	23.0	56.0	25.0	35.0	42.0	126.0	17.0	7.0	
400-4 x 8TQ	400-4 x 10TQ	400	36.0	27.0	56.0	25.0	35.0	44.0	126.0	17.0	8.5	
500-4 x 8TQ	500-4 x 10TQ	500	38.0	30.0	56.0	25.0	35.0	65.0	150.0	17.0	8.0	
630-4 x 8TQ	630-4 x 10TQ	630	44.0	34.0	63.0	25.0	35.0	65.0	150.0	17.0	10.0	

For recommended tooling refer to TQ terminals.

## Extended Palm 2 Hole Terminals

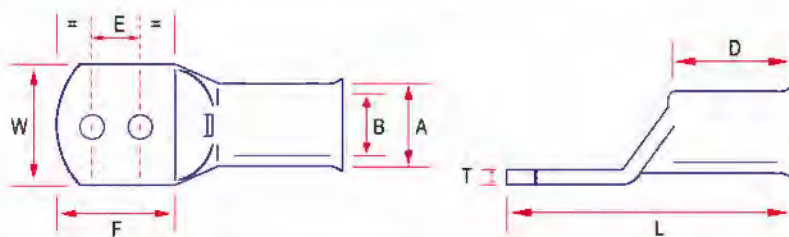

Part No.	Cond. Size mm <sup>2</sup>	Stud Hole	Dimensions mm								
			A	B	W	E	F	D	L	T	
10-6POI	10	6	6.9	4.6	11.0	16.0	34.0	10.0	50.0	2.0	
16-6POI	16	6	8.0	5.6	11.0	16.0	34.0	11.0	52.0	2.2	
25-6POI	25	6	9.5	7.0	13.5	16.0	34.0	13.0	56.0	2.4	
35-6POI	35	6	11.0	8.2	15.5	16.0	34.0	18.0	57.0	2.8	
50-6POI	50	6	11.9	9.5	17.0	45.0	75.0	18.0	83.0	2.5	
70-12POI	70	12.5	15.0	11.5	21.2	45.0	75.0	18.0	105.0	2.0	
95-12POI	95	12.5	17.0	13.5	24.3	45.0	75.0	24.0	111.0	3.5	
120-12POI	120	12.5	19.0	15.0	27.2	45.0	75.0	27.0	115.0	4.0	
150-12POI	150	12.5	21.0	16.5	30.0	45.0	75.0	27.0	120.0	4.5	
185-12POI	185	12.5	23.0	18.5	33.5	45.0	75.0	30.0	125.0	4.5	

Alternative stud hole sizes, hole centres, and blank palms are available to special order.

Larger sizes available on request

For recommended tooling refer to TQ terminals.



# Copper Tube Terminals



## Reduced Palm Heavy Duty Terminals

**Application:** For L.V. circuit breakers with reduced space terminal blocks for immediate and easier installation.

**Material:** Manufactured from seamless copper tube to BS EN 12449:2012

**Finish:** Electro Tin plated to BS 1872:1974

- All terminals are manufactured from 99.5% copper and fully annealed to ensure optimum ductility to avoid severe deformation such as cracking and splitting when crimped
- Internal barrel diameters suit standard cables as defined in BS 6360
- All SWA terminals are identified on the palm with cable size (and stud hole size) to ensure correct selection of the appropriate tool and dies

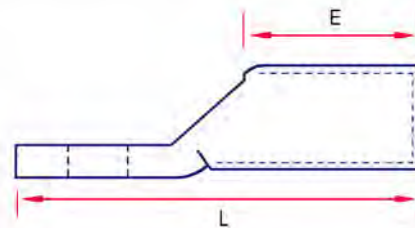
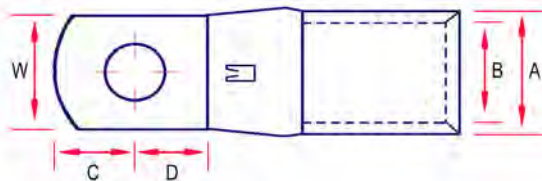

Part No.	Cond. Size mm <sup>2</sup>	Stud Hole	Dimensions mm						
			A	B	C	D	E	W	L
10-5TRP	10	M5	6.9	4.5	6.0	6.5	9.0	9.0	26.0
16-5TRP	16	M5	7.9	5.6	6.0	6.5	11.0	9.0	29.0
25-5TRP	25	M5	9.5	7.0	6.0	6.5	13.0	9.0	31.5
35-6TRP	35	M6	11.0	8.2	7.0	8.0	14.0	11.5	36.5
50-6TRP	50	M6	12.1	9.5	7.0	8.0	18.0	11.5	40.5
70-6TRP	70	M6	15.0	11.5	7.0	8.0	18.0	11.5	44.0
95-8TRP	95	M8	17.0	13.5	8.0	9.0	24.0	15.5	52.5
120-8TRP	120	M8	19.0	15.0	9.0	14.0	27.0	19.0	60.0
120-10TRP	120	M10	19.0	15.0	9.0	14.0	27.0	19.0	60.0
150-8TRP	150	M8	21.0	16.5	9.0	18.0	27.0	19.0	70.0
150-10TRP	150	M10	21.0	16.5	9.0	18.0	27.0	19.0	70.0
185-10TRP	185	M10	23.0	18.5	9.0	18.0	30.0	24.5	77.0
240-10TRP	240	M10	26.0	21.0	9.0	13.0	32.0	31.0	80.0
240-12TRP	240	M12	26.0	21.0	12.0	16.0	32.0	31.0	86.0
240-16TRP	240	M16	26.0	21.0	17.0	19.0	32.0	31.0	94.0
300-12TRP	300	M12	28.0	23.0	12.0	16.0	37.0	31.0	95.0

For recommended tooling refer to TQ terminals.

# Sicon Shear-Bolt Connectors

- Only 3 sizes of connector required to cover conductors 10 to 300mm<sup>2</sup>
- Greatly reduces installation time - no need for crimp tools, only impact driver with allen key
- The best connections for voltages up to 36kV
- Suitable for both copper or aluminium - stranded or solid
- Innovative slip-disc base design to ensure no damage to the conductors
- Bolts always shear-off below barrel of terminal - 98 separate breaking points
- Guaranteed electrical and mechanical connection



SICON - The Bolted Connector with Stepless Shear Bolts for Low and Medium Voltage Cables.

## Technical Features:

- Large clamping range: 10 - 95mm<sup>2</sup>; 25 - 150mm<sup>2</sup>; 50 - 240mm<sup>2</sup>; 95 - 300mm<sup>2</sup>; 300 - 630mm<sup>2</sup>; 6 - 3/0 kcm; 2 - 250 kcm; 1/0 - 500 kcm; 4/0 - 600 kcm; 500 - 1000 kcm (others on request)
- Centric cable guide with different centring sleeves
- Conductor channels with transverse groove and protection against conductor oxidation
- Blind hole designed as pressure-resistant oil barrier for impregnated cables
- Compact design: Rounded edges and flat transitions suitable for slide-on and shrink sleeves
- Contact technology type-tested to IEC 61238-1
- Proven in joint tests to HD 629 and in 18-month endurance test

## Shear Bolt Connectors

Part No.	Dimensions mm			No. of Screws	Round (mm <sup>2</sup> )	Round and Compacted (mm <sup>2</sup> )	Solid Alum. & Copper Cond. (mm <sup>2</sup> )	Hexagon key	Mounting Hole (mm)
	D O	d O	L						
SBC10-95	24	13	70	1	10-95	10-95	10-70	4mm-3/16"	13
SBC50-240	33	20	115	2	50-185	50-240	50-185	6mm-1/4"	13
SBC95-300	38	24	120	2	95-300	95-300	95-240	8mm-5/16"	13

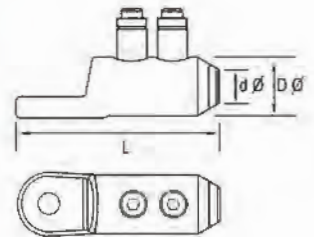

## Shear Bolt Splices Connectors

Part No.	Dimensions mm			No. of Screws	Round (mm <sup>2</sup> )	Round and Compacted (mm <sup>2</sup> )	Solid Alum. & Copper Cond. (mm <sup>2</sup> )	Hexagon key
	D O	d O	L					
SBS10-95	24	13	65	2	10-95	10-95	10-70	4mm-3/16"
SBS50-240	33	20	126	4	50-185	50-240	50-185	6mm-1/4"
SBS95-300	38	24	140	4	95-300	95-300	95-240	8mm-5/16"

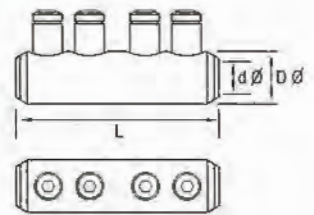

## Tap Connectors

Part No.	Dimensions mm		No. of Screws	Round (mm <sup>2</sup> )	Round and Compacted (mm <sup>2</sup> )	Solid Alum. & Copper Cond. (mm <sup>2</sup> )	Hexagon key
	d O	L					
SBT50-240	20	162	6	50-185	50-240	50-185	6mm-1/4"

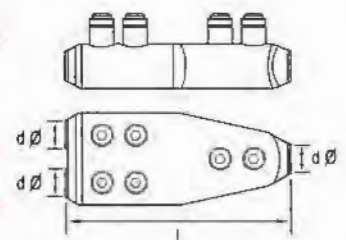

# Copper Tube Splices

Application: Un-insulated heavy duty terminals suitable for power cables up to 1000 volts.

Material: Manufactured from seamless copper tube to BS EN 12449: 2012

Finish: Electro Tin plated to BS 1872:1974

- All terminals are manufactured from 99.5% copper and fully annealed to ensure optimum ductility to avoid severe deformation such as cracking and splitting when crimped
- Internal barrel diameters suit standard cables as defined in BS 6360
- All SWA terminals are identified on the palm with cable size (and stud hole size) to ensure correct selection of the appropriate tool and dies

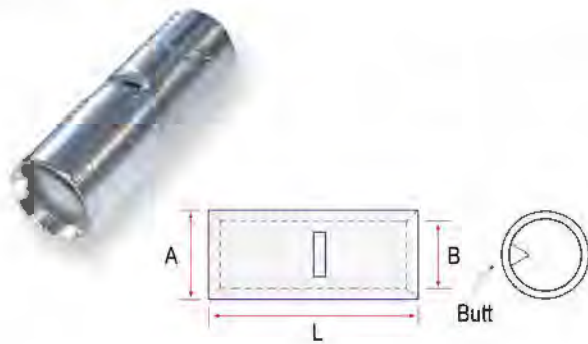

## Butt Splices

Part No.	Pack Qty	Cond. Size mm <sup>2</sup>	Dimensions mm			
			A	B	L	
1.5BS	100	1.5	3.3	1.8	14.0	
2.5BS	100	2.5	4.2	2.3	16.0	
4BS	100	4.0	5.0	3.0	19.0	
6BS	100	6.0	6.0	4.0	22.0	
10BS	50	10	6.9	4.4	25.0	
16BS	10	16	8.0	5.6	30.0	
25BS	10	25	9.5	7.0	35.0	
35BS	10	35	11.0	8.2	39.0	
50BS	10	50	12.1	9.5	44.0	
70BS	10	70	15.0	11.5	44.0	
95BS	10	95	17.0	13.5	55.0	
120BS	10	120	19.0	15.0	63.0	
150BS	10	150	21.0	16.5	66.0	
185BS	10	185	23.0	18.5	74.0	
240BS	5	240	26.0	21.0	80.0	
300BS	5	300	28.0	23.0	89.0	
400BS	5	400	32.0	27.0	90.0	
500BS	2	500	38.1	30.0	135.0	
630BS	2	630	44.0	33.8	135.0	
800BS	-	800	49.0	38.0	135.0	POA
1000BS	-	1000	53.0	42.5	135.0	POA

For recommended tooling refer to TQ terminals

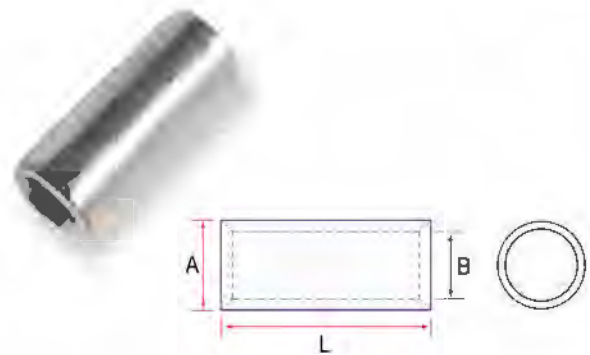

## Parallel Splices

Part No.	Pack Qty	Cond. Size mm <sup>2</sup>	Dimensions mm		
			A	B	L
10PS	50	10	6.9	4.5	13.0
16PS	10	16	7.9	5.6	13.0
25PS	10	25	9.5	7.0	15.0
35PS	10	35	11.0	8.2	16.0
50PS	10	50	12.1	9.5	18.0
70PS	10	70	15.0	11.5	24.0

For recommended tooling refer to TQ terminals  
Sold in eaches

# Copper Reducing Pin Terminals

## Un-insulated Solid Reducing Copper Pin Terminal

**Material:** Electrolytic Copper

**Finish:** Electro-Tin Plated

**Voltage:** 600 - 1000V



Part No.	Cond. Size mm <sup>2</sup>	Dimensions mm			
		A	B	C	D
10USP	10	10	13	6.2	3.8
16USP	16	13	17	7.1	3.8
25USP	25	20	17	9.0	5.0
35USP	35	20	17	10.6	5.0
50USP	50	20	21	12.4	7.5
70USP	70	20	23	14.7	8.0
95USP	95	20	26	17.5	8.0
120USP	120	25	25	19.4	11.5
150USP	150	32	32	21.5	11.5
185USP	185	32	32	24.0	11.5
240USP	240	32	32	27.3	15.6
300USP	300	32	32	30.6	15.6

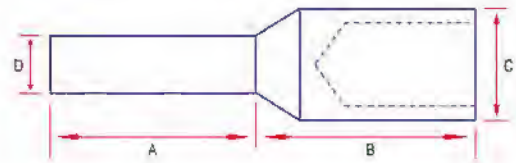

Alternative pin lengths/diameters are available to special order.  
Special bespoke version to customer specification available - ask for details.  
Sold in eaches.

## Un-insulated Reducing Pin Terminal

**Material:** Electrolytic Copper

**Finish:** Electro-Tin Plated

**Voltage:** 600 - 1000V



Part No.	Cond. Size mm <sup>2</sup>	Dimensions mm			
		A	B	C	D
10UP	10	4.8	4.3	14.5	23.5
16UP	16	5.9	5.5	18.0	28.0
25UP	25	7.0	7.0	20.3	32.0
35UP	35	8.9	8.0	24.5	39.0
50UP	50	10.0	9.5	26.0	45.0
70UP	70	11.5	11.0	31.0	55.0

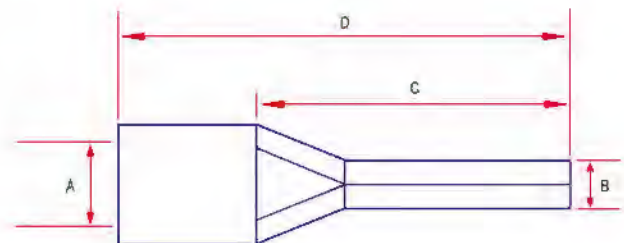

Sold in eaches.

See page 165 for recommended tooling. Note: UP Pins should only be crimped using an indent-style tool.

**Bootlace Ferrules: SAB-BLF**

Selection of Bootlace Ferrules 0.5mm<sup>2</sup> - 6mm<sup>2</sup>



**Pre-insulated Terminals: SAB-PRE**

Selection of Pre-insulated Terminals 1.5mm<sup>2</sup> - 6mm<sup>2</sup>

**Cable Tie Mounts: SAB-CTB**

Selection of Adhesive Cable Tie Mounts and Fixing Bolts



**Heatshrink Sleeving: SAB-HS**

Selection of Heatshrink Sleeving 6.4mm - 12.7mm

**Heatshrink Terminals: SAB-HST**

Selection of Heatshrink Terminals  
1.5mm<sup>2</sup> - 6.0mm<sup>2</sup>



**Splices: SAB-SPL**

Selection of Splices 1.5mm<sup>2</sup> - 16mm<sup>2</sup>



### **Strip & Push-In Connectors: SAB-CONS**

Selection of 12 Way Strip & Push-In Connectors (2, 4, 6 & 8 Ways)

### **Push-In Connectors: SAB-PIC**

Selection of Push-In Connectors  
(see page 38 for technical details)



### **Piano Key Connectors: SAB-PKC**

Selection of 3 Way Piano Key Connectors  
(see page 38 for technical details)

### **Piano Key Connectors: SAB-PKC5**

Selection of 5 Way Piano Key Connectors  
(see page 38 for technical details)



### **Piano Key Connectors: SAB-PKC35**

Selection of 3 and 5 Way Piano Key Connectors  
(see page 38 for technical details)

### **Copper Tube Terminals: SAB-CTT**

Selection of Copper Tube Terminals 10mm<sup>2</sup> - 70mm<sup>2</sup>



**Self-Tapping Screws: SAB-ST5**

Selection of Self-Tapping Screws size 6 - 10

**Socket Screws & Stud Extensions: SAB-SCR**

Selection of Socket Screws 3.5 x 25mm, 3.5 x 35mm, 3.5 x 40mm, 3.5 x 50mm and 3.5 x 75mm and 3.5mm Stud Extensions

**PVC Grommets: SAB-GRO**

Selection of Open and Closed PVC Grommets 20mm and 25mm

**Hose Clamps & Constant Force Springs:****SAB-JC**

Selection of Hose Clamps and Constant Force Springs 10mm - 35mm

**Selekt-A-Box™ Stand: SAB-STD**

Wire Selekt-A-Box™ Display Stand

**Selekt-A-Box™ Stand: SAB-TCD**

Selekt-A-Box™ Stand Graphics

**Pozi-countersunk Woodscrews BZP: FAB-PCS**

Pozi-countersunk twin thread woodscrews BZP contains a selection of 4.2x13, 4.2x16, 4.2x19, 4.2x25, 4.8x16, 4.8x19, 4.8x25, 5.5x19, 5.5x25, 5.5x32

**Hex Head Self Drilling Screws BZP: FAB-HHS**

Hex head self drilling screws BZP contains a selection of 4.2x13, 4.2x16, 4.2x19, 4.2x25, 4.8x16, 4.8x19, 4.8x25, 5.5x19, 5.5x25, 5.5x32

**Pozi Pan Head Self Drilling Screws BZP:****FAB-PPS**

Pozi pan head self drilling screws BZP contains a selection of 3.5x9.5, 3.5x13, 3.5x19, 4.2x13, 4.2x16, 4.2x19, 4.2x25, 4.8x13, 4.8x19, 4.8x25

**Flat Form A Washers: FAB-FAW**

Flat form A washers contains a selection of M5A, M6A, M8A, M10A, M12A, M16A

**Chipboard Screws BZP: FAB-CS**

Chipboard screws BZP contains a selection of 3.5x12, 3.5x20, 3.5x25, 4.0x16, 4.0x25, 4.0x30, 4.0x50, 5.0x25, 5.0x30, 5.0x40

**Slot Pan Head Machine Screws, Nuts & Washers: FAB-SPH**

Slot pan head machine screws contains a selection of M4x8, M4x10, M4x12, M4x16, M4x20, M4x25, M4x30, M4x40, plus nuts and washers



**Roofing Bolts & Nuts BZP: FAB-RBN**

Roofing bolts and nuts BZP contains a selection of M6x10, M6x12, M6x16, M6x20, M6x25, M6x30, M6x40, M6x50, M6x60, M6x80 plus M6 square nuts.

**Brass Bolts: FAB-BB**

Brass bolts contains a selection of M6x12, M6x20, M6x30, M8x20, M8x30, M8x50, M10x20, M10x30, M10x50, M12x30

**Brass Washers: FAB-BW**

Brass washers contains a selection of M4, M5, M6, M8, M10, M12, M16, M20

**Brass Nuts: FAB-BN**

Brass nuts contains a selection of M4, M5, M6, M8, M10, M12, M16, M20

**Pozi Pan-Head: FAB-PPS**

Selection of Pozi pan-head self drillers BZP  
Sizes 3.2 x 9.5 to 4.8 x 25

**Fix-A-Box™ Display Stand: FAB-STD**

Fix-A-Box Display Stand

**Fix-A-Box™ Stand Graphics: FAB-TCD**

Fix-A-Box Stand Graphics



## Terminal Kit Boxes

### **Crimp Tool & Pre-insulated Terminals: PK156**

Complete with hand ratchet crimp tool and a selection of pre-insulated terminals 0.5mm<sup>2</sup> - 6.0mm<sup>2</sup>



### **Crimp Tool & Copper Tube Terminals: EK1016**

Complete with hand ratchet crimp tool and a selection of 10mm<sup>2</sup> & 16mm<sup>2</sup> copper tube terminals

### **Crimp Tool & Bootlace Ferrules: BK0540**

Complete with hand ratchet crimp tool and a selection of insulated bootlace ferrules 0.5mm<sup>2</sup> - 4.0mm<sup>2</sup>



### **Pre-insulated Terminals: LAR-PRE-KIT**

Complete with a selection of 18 popular types of pre-insulated terminals 0.5mm<sup>2</sup> - 6.0mm<sup>2</sup>

### **COP650-kit**

Complete with an assortment of 15 popular types of copper tube terminals 6mm<sup>2</sup> - 50mm<sup>2</sup>



### **PAN-PRE-KIT**

Complete with an assortment of 5 sizes of insulated bootlace ferrules 0.5mm<sup>2</sup> - 2.5mm<sup>2</sup> and 7 types of popular pre-insulated terminals 0.5mm<sup>2</sup> - 6.0mm<sup>2</sup>

### **PAN-KIT**

Complete with an assortment of 6 sizes of insulated bootlace ferrules 0.5mm<sup>2</sup> - 4.0mm<sup>2</sup> and 6 types of popular pre-insulated pin and flat blade terminals 0.5mm<sup>2</sup> - 6.0mm<sup>2</sup>.



## Fixing Tubs: TUB-RPS, TUB-BPS, TUB-CFS

### The new way to transport those all-important fixings

A range of popular fixings in transparent tubs. Easy to see when stocks are running low, each with re-sealable lid. No more frustrating spills. SWA - making life easier for busy contractors



Part No.	Description
TUB-RPS	500 - Red Wall Plugs, 500 - 8x1 1/2" Countersunk Wood Screws, 1xNo.8 Masonry Drill, 1xNo.2 Pozidrive Drill Bit
TUB-BPS	400 - Brown Wall Plugs, 400 - 10x2" Countersunk Wood Screws, 1xNo.10 Masonry Drill, 1xNo.2 Pozidrive Drill Bit
TUB-CFS	200 - Self-Drilling Caving Fixings complete with 200 - Screws, 1xNo.2 Pozidrive Drill Bit

## Aluminium Terminals

### 4 Core Sectorial Aluminium Conductor

Part No.	Conductor Size mm <sup>2</sup>	Stud Hole Size mm	Number of Indents Required
4SLM35	35	12	2
4SLM50	50	12	2
4SLM70	70	12	2
4SLM95	95	12	3
4SLM120	120	12	3
4SLM150	150	12	3
4SLM185	185	12	3
4SLM240	240	12	3
4SLM300	300	12	3



- Used on solid sectorial-shaped aluminium cores
- Die positional marks to ensure correct crimping

For details of other aluminium terminals available please contact SWA. Hire tools available to suit

### Electrical Joint Compound - Unial Paste

- Recommended for use on aluminium to aluminium and aluminium to copper connections, on all bare conductors and bus bars
- Assumes a high conductivity joint by sealing out air and moisture to prevent corrosion and reformation of oxide film

Part No.	Volume
UN225	225ml



# Terminal Connectors

## “Push-In” Wire Connectors

Quick, reliable, easy and convenient way for the installation of cable conductors in a range of electrical wiring applications.

- Can be applied without the need for any tools
- Transparent housing allows a fast and easy visual check
- For use on both solid and flexible conductors
- Easy to use - strip and insert into connector
- To release, simply twist left and right while pulling to release the conductor



Part No.	Colour	Cable range mm <sup>2</sup>		Volt rating	Amp rating
		Solid	Flexible		
PIC2	2-way Orange	0.75 - 2.5	1.5 - 2.5	400	24
PIC4	4-way Blue	0.75 - 2.5	1.5 - 2.5	400	24
PIC6	6-way Black	0.75 - 2.5	1.5 - 2.5	600	20
PIC8	8-way Grey	0.75 - 2.5	1.5 - 2.5	600	20

EN 60998-1:2001  
 EN 60998-2-2:2004  
 UL & CSA approved  
 RoHS compliant

Pack Quantity: 10

## Piano Key Connectors

The new range of piano key push-in wire connectors are ideal for a quick, reliable, easy and convenient way for the installation of cable conductors in a range of electrical wiring applications.

- Quick Release
- Can be applied without the need for any tools
- For use on both solid and flexible conductors
- Easy to use - strip and insert into connector

Wire Cross Section: From 0.75mm<sup>2</sup> to 2.50mm<sup>2</sup>

Cable Types: Solid & flexible wires

Operating Voltage: 400 V AC

Operating Current: 24 A (max)

Operating Temperature: -30°C to +110°C

Flammability Class: V0 according UL94

Approvals: EN 60998-1, EN 60998-2

Cable Stripping Length: 16mm

Housing Material: Plastic GWT 960°C

Contact Material: Electrolytic Copper

Spring Material: Hardened Steel



Part No.	Pole	Length (mm)	Depth (mm)	Height closed (mm)	Height open (mm)	Pack Quantity
PKC3	3	16	21.1	14.8	24	10
PKC5	5	25.8	21.1	14.8	24	10

Selekt-A-Box™ versions are also available see page 28

# Terminal Connectors



## 12-Way Terminal Strip Connector

### Description

Manufactured and tested according to international standards, SWA terminal strips are designed for electrical appliances, lighting fixtures, small transformers and for all kinds of applications that require safety connections with the ability of withstanding high temperatures.

#### PE - POLYETHYLENE

C.E APPROVED

Working Temperature: -40°C to +65°C

Material: Contacts - Brass  
Screws - Steel, Zinc-plated

Voltage: 250-450V

Colour: Natural

#### PA - POLYAMIDE 66

Self-extinguishing 94 V2

Approved to BS EN 60998

Low voltage directive 2006/95/CE

Working Temperature: -30°C to +110°C

Material: Contacts - Brass  
Screws - Steel, Zinc-plated

Voltage: 250-450V

Colour: Natural

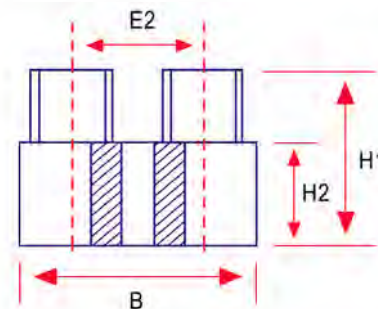
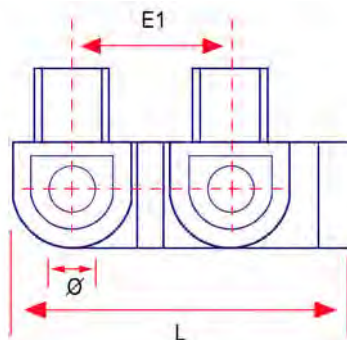

Part No.		Amp	mm <sup>2</sup>	Dimensions mm						
PE	PA			L	B	H1	Ø	E1	E2	H2
12WSC3	12WSC3-PA	3	4	93.3	13.3	11.1	2.8	8.0	4.2	6.3
12WSC5	12WSC5-PA	5	6	117.6	14.4	13.9	3.0	10.0	4.5	7.5
12WSC10	12WSC10-PA	10	10	132.4	18.2	15.0	4.0	11.1	5.4	8.4
12WSC15	12WSC15-PA	15	12	141.2	20.0	17.3	4.3	12.0	6.6	9.1
12WSC30	12WSC30-PA	30	16	168.7	22.3	18.8	4.6	14.4	7.5	10.8
12WSC60	12WSC60-PA	60	25	190.9	26.6	22.9	6.2	16.3	8.3	13.4

All supplied in pack quantity of 10 pieces

# Solar PV Terminals & Tools



MC4: Approval No. TUV DIN EN 50521:2008  
VDE 0126-3/2009-10

## High-Precision Ratchet Crimp Tool: RTMC4

- High-precision ratchet mechanism
- 1.2 metric tons of pressure at the crimping face with minimum hand effort
- Interchangeable high-precision crimping die set
- Interchangeable magnetic locator for precision positioning of terminals
- Ratchet release point in case of user error when crimping
- Crimping range of 2.5/4/6mm<sup>2</sup> (AWG14/12/10)



## MC4 Male & Female Connector: MC4C



- MC4 connector - male & female complete
- 2.5 /4/6mm<sup>2</sup>
- Flame retardant / UV Resistant UL94-VO
- IP67 rated
- Rated voltage: 1000V DC
- Rated Current: 20 amp
- Temperature range: -40°C to +90°C
- Material: PPO

MC4C: Male & female complete  
MC4-MC: Male pin & housing only  
MC4-FC: Female pin & housing only  
MC4-M: Male pin only  
MC4-F: Female pin only

## MC4 Male & Female Panel Connector: MC4P

- MC4 panel connector - male & female complete
- 2.5 /4/6mm<sup>2</sup>
- Flame retardant / UV Resistant UL94-VO
- IP67 rated
- Rated voltage: 1000V DC
- Rated Current: 20 amp
- Temperature range: -40°C to +90°C
- Material: PPO



## MC4 Branch Connector: MC4T1M2F & MC4T1F2M



MC4T1F2M

MC4T1M2F

- MC4 branch connector
- 2.5 /4/6mm<sup>2</sup>
- Flame retardant / UV Resistant UL94-VO
- IP67 rated
- Rated voltage: 1000V DC
- Rated Current: 20 amp
- Temperature range: -40°C to +90°C
- Material: PPO

MC4T1M2F: 1 x male, 2 x female entries  
MC4T1F2M: 2 x male, 1 x female entries

## Solar PV Terminals & Tools

### MC3 Connector: MC3C-4 & MC3C-6

MC3C-4:	MC3C-6:
2.5 - 4mm <sup>2</sup>	6mm <sup>2</sup>
IP67 rated	IP67 rated



### MC3 Panel Connector: MCP-4 & MCP-6

MCP-4:	MCP-6:
2.5 - 4mm <sup>2</sup>	6mm <sup>2</sup>
IP67 rated	IP67 rated

### MC3 Branch Connector: MC3T1M2F & MC3T1F2M

- MC3 branch connector
- 2.5 /4/6mm<sup>2</sup>
- IP67 rated

MC3T1M2F: 1 x male, 2 x female entries

MC3T1F2M: 2 x male, 1 x female entries



### MC4 Open-end Spanner & Quick Disconnect: S-MC4



Supplied as a pair



Part No. 4320-0612: Self-adjusting cut and strip tool frame only.  
Supplied without blade cassette.



Part No. 4320-0615: V-blade stripping cassette  
for 4320-0612. Designed to strip PTFE style hard  
insulation wires and solar cable from 0.1mm<sup>2</sup> - 4.0mm<sup>2</sup>

### PV Cable Stripping Tool





# MICC PRODUCTS

## What is Mineral Insulated Copper Clad cable or MICC cable for short?

MICC is a specialised electrical cable made from copper conductors inside a copper sheath, insulated by inorganic magnesium oxide powder.

Approved by strict electrical codes it is installed in areas of high fire risk where total critical fire protection is paramount. In designated fire tests representative of actual fire conditions it has been shown that it will survive longer than the structure. In the event of a fire the use of MICC cabling ensures circuit reliability for power and control circuits of critical equipment including alarm circuits, fire pumps and smoke control systems.

Our quality range of MICC accessories is the perfect partner for MICC cabling. Manufactured to the most stringent standards and the highest approved safety regulations you can't buy better.

To complement the accessory range we also have a superb range of MICC tools made to our usual high standard making your job just that little bit easier.



### GLANDS

For use on MICC cables, the glands are compatible with Zone 1 & 2 EExd flameproof enclosures.



### POTS & SEALS

Comprising of Pots & Seals with Earth Tail, Sealing Compound and Stub Caps.



### CLIPS & SADDLES

C106 with a Low Smoke & Fume coating available in a range of colours to secure MICC cabling.



### GLAND SHROUDS

Available in PVC and low smoke material in a range of colours.



### EXTENSION & STUB SLEEVING

Designed to satisfy BS2848/3/2051 Type 4 and US Underwriters Laboratories 105°C requirements.



### RMX - SEALING COMPOUND

For filling cavities and making airtight/watertight joints in electrical equipment.

## MICC TOOLING



ATEX



**ZSJ "JOI STRIPPER**  
For stripping cable sheath for cables.



**ZPM20**  
For screwing pots onto cables.



**ZDC20**  
For crimping stub caps into pots.



**ZR**  
Ringing tool for cutting cable neatly.



Cable Size	Gland	Standard Type Plain Seals	Pots & Seals c/w earth tails	PVC Shroud	LSF Shroud
2L1.0	RM2L1.0-10	RPS2L1.0-10	RPSL2L1.0-10	RHG20-10	RXG20-10
2L1.5	RM2L1.5-10	RPS2L1.5-10	RPSL2L1.5-10	RHG20-10	RXG20-10
2L2.5	RM2L2.5-10	RPS2L2.5-10	RPSL2L2.5-10	RHG20-10	RXG20-10
3L1.0	RM3L1.0-10	RPS3L1.0-10	RPSL3L1.0-10	RHG20-10	RXG20-10
3L1.5	RM3L1.5-10	RPS3L1.5-10	RPSL3L1.5-10	RHG20-10	RXG20-10
4L1.0	RM4L1.0-10	RPS4L1.0-10	RPSL4L1.0-10	RHG20-10	RXG20-10
4L1.5	RM4L1.5-10	RPS4L1.5-10	RPSL4L1.5-10	RHG20-10	RXG20-10

Pack Quantities: 10 Shrouds available in orange, red, white and black.  
RHG25 shrouds also available in orange, white and red

## Clips & Saddles

Cable Size	Plastic coated clips	LSF Powder coated clips	Bare copper clips	Plastic coated saddles	LSF Powder coated saddles	Cable Diameter (mm)	
	RCHJ*-50	RCHL*-50	RC(size)-50	RSFJ*-50	RSFL*-50	Covered	Bare
2L1.0	30	26	20	272	272	6.4	5.1
2L1.5	32	28	22	302	302	7.0	5.7
2L2.5	34	30	26	342	342	7.9	6.6
2L4.0	40	37	30	382	382	9.2	7.7
3L1.0	32	28	22	302	302	7.1	5.8
3L1.5	34	32	24	342	342	7.7	6.4
3L2.5	37	34	28	342	342	8.8	7.3
4L1.0	34	32	24	342	342	7.6	6.3
4L1.5	37	34	28	342	342	8.3	7.0
4L2.5	43	40	32	422	422	9.6	8.1

Pack Quantities: 50 \*Suffix Black, Red, Orange, White

**Product Description:** A range of clips and saddles to compliment fire resistant type cables in securing them to any range of surfaces.

**Raw Material:** Stamped from chamfered edge copper strip C106.

### Coating (RCHL and RSFL):

Chemical type: Polyester, Application: Electrostatic spray, Dry film thickness: From 40-100 microns (typically 50 microns).

### Mechanical Properties:

Adhesion (BS 3900 E3): Pass 1mm cross-hatch, class 0

Impact Resistance (BS 3900 E3): Pass 220"/lb indentation to 2.5mm

Flexibility (BS 3900 E11): Pass 1/4" conical mandrel

Erichsen Cupping (BS 3900 E4): Pass 8mm

Scratch Resistance (BS 3900 E2): Pass 400gms no penetration to substrate



## FP200 Clips & Saddles Selection Chart

Cable (mm)	Cores	Plastic Clips	Plastic Saddles	LSF Powder Coated Clips	LSF Powder Coated Saddles
1.0	2 core + Earth	RCHJ32	RSFJ302	RCHL28	RSFL302
1.0	3 core + Earth	RCHJ34	RSFJ342	RCHL32	RSFL342
1.0	4 core + Earth	RCHJ37	RSFJ342	RCHL34	RSFL342
1.5	2 core + Earth	RCHJ34	RSFJ342	RCHL32	RSFL342
1.5	3 core + Earth	RCHJ37	RSFJ342	RCHL34	RSFL342
1.5	4 core + Earth	RCHJ40	RSFJ382	RCHL37	RSFL422
2.5	2 core + Earth	RCHJ40	RSFJ382	RCHL37	RSFL422
2.5	3 core + Earth	RCHJ43	RSFJ422	RCHL37	RSFL422
2.5	4 core + Earth	RCHJ47	RSFJ462	RCHL43	RSFL462
4.0	2 core + Earth	RCHJ47	RSFJ462	RCHL43	RSFL462
4.0	3 core + Earth	RCHJ47	RSFJ462	RCHL43	RSFL462
4.0	4 core + Earth	RCHJ47	RSFJ462	RCHL43	RSFL462

	Nominal cross sectional area mm <sup>2</sup>	Construction	Mean overall diameter	Max. conductor resistance at 20°C ohms/km	Current rating DC or single phase AC enclosed amps	Current rating DC or single phase AC clipped direct amps	Volt drop DC or single phase AC mV/A/m
Two Core FP200	1.0	1 / 1.13	8.0	18.1	13	15	44
	1.5	1 / 1.38	8.1	12.1	16.5	19.5	29
	2.5	1 / 1.78	9.5	7.4	23	27	18
	4.0	7 / 0.85	11.6	4.6	30	36	11
Three Core FP200	1.0	1 / 1.13	8.2	18.1	13	15	44
	1.5	1 / 1.38	8.4	12.1	16.5	19.5	29
	2.5	1 / 1.78	10.4	7.4	23	27	18
	4.0	7 / 0.85	12.3	4.6	30	36	11
Four Core FP200	1.0	1 / 1.13	8.5	18.1	13	15	44
	1.5	1 / 1.38	10	12.1	16.5	19.5	29
	2.5	1 / 1.78	11.9	7.4	23	27	18
	4.0	7 / 0.85	13.5	4.6	30	36	11

FP200 Gold<sup>®</sup> is also available in multi-core versions (7, 12 and 19 core configurations).

## MICC Products



### Sealing Compound

For filling cavities and making air-tight and watertight joints, especially in electrical equipment to exclude moisture.

Part No.	Pack Size
RMX	100g

**Type:** Non oxidizing resin/oil based compound suitably filled with inert mineral fillers.

**Appearance:** Grey putty-like finish.

**Consistency:** Putty-like.

**Flash Point:** Minimum 200°C

**Temp. Range:** 150°C continuous

**Breakdown Strength:** When tested in a cell with a 4mm gap at 18°C the compound withstood 25kV for 1 minute.



## MICC Tooling

### ZSJ - "JOI Stripper"

For stripping cable sheath for cables 2L1.0, 2L1.5, 2L2.5, 3L1.0, 3L1.5, 4L1.0, 4L1.5



### ZSJB

Replacement blade for ZSJ



### ZPM20

For screwing pots onto cables



### ZDC20

For crimping stub caps into pots



### ZR

Ringing tool for cutting cable neatly



# CABLE GLANDS & ACCESSORIES

## CABLE GLANDS & ACCESSORIES

	<b>EarthingNut™</b> .....	<b>44</b>
	<b>TAURAS™</b> <small>Use with Confidence FastFit Glands</small> <b>Fast Fit Range of Cable Glands</b> .....	<b>45-51</b>
	<b>PEX Brass Cable Glands</b> .....	<b>52-53</b>
	<b>Premier Brass Cable Glands</b> .....	<b>54-58</b>
	<b>Accessories For Cable Glands</b> .....	<b>65 &amp; 71</b>
	<b>Hazardous Area Cable Glands</b> .....	<b>60-64</b>
	<b>Hazardous Area Cable Accessories</b> .....	<b>66</b>
	<b>Cable Gland Sizing Charts</b> .....	<b>68-72</b>
	<b>Aluminium Cable Glands</b> .....	<b>73</b>
	<b>Polyamide Cable Glands</b> .....	<b>74-76</b>
	<b>Food Hygiene Glands &amp; Fittings</b> .....	<b>77-78</b>
	<b>EMC Cable Glands</b> .....	<b>79-80</b>



**EarthingNuts™ So simple it's nuts to use anything else!**

EarthingNuts™ will change the way you terminate and earth metal cable glands forever!

### Electrical Industry Awards Winner - Innovative Power Products

- No extra drilling required - saving up to **60%** on fitting time than conventional methods and does not compromise the enclosure IP rating
- Improved safety during fitting and in service
- Fitted right first time every time
- Replaces the traditional "banjo" earth-tag and lock-nut
- Unique cutting teeth bite into the box wall so that the gland can be tightened with one tool from the outside
- Teeth provide voltage equalising connection to EMI shielding
- Enable a direct high integrity connection for protective earthing
- Grub screw secures nut to the gland ensuring continuity, even if the enclosure becomes damaged



Scan to view the demo



- 1 Front facing connection
- 2 Locking Grubscrew
- 3 Anti rotation teeth

Part No.	To Suit Thread Size (mm)	Pack Quantity
BELN20-PK2	20	2
BELN20-PK10	20	10
BELN25-PK2	25	2
BELN25-PK10	25	10
BELN32-PK2	32	2
BELN40-PK1	40	1
BELN50-PK1	50	1
BELN63-PK1	63	1
BELN75-PK1	75	1

Supplied with grub screw(s), connecting bolt, & Allen key



Patented in the UK and Ireland No. EP1790053. Other international patents granted and pending. The Squirrel logo is a Registered Trade Mark of Cable Terminology Ltd



To include Earthing Nut

# TPBW RANGE

**60% QUICKER INSTALLATION**

Complete with the Award Winning EarthingNut™

Innovative Power Product of the Year

**Taurus™ PEX® BW Indoor Brass Cable Gland Pack**

**with award-winning EarthingNut™**

Application: Brass indoor gland suitable for all types of steel wire armoured cable (SWA), providing mechanical cable retention and electrical continuity via armour wire termination.

Operating Temperature: -80°C to + 300°C

Ingress Protection: IP2X

Approval: BS 6121 Part 1:2005



Everything supplied to terminate the gland in one convenient kit



Scan to view the demo

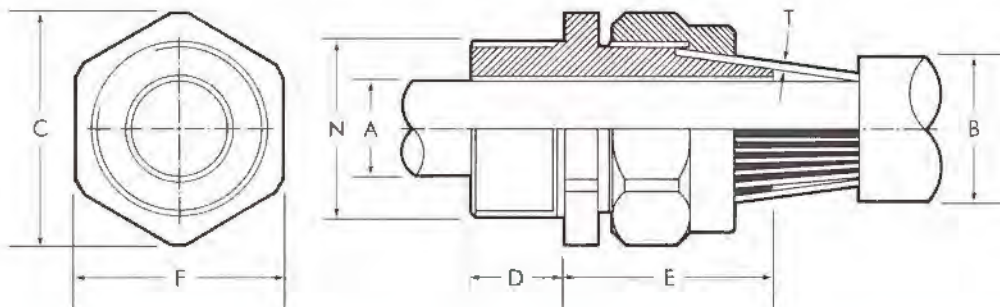

Part No.	Pack Quantity	Entry Thread		Cable Acceptance Details			Hexagonal Details		Assembled Length E
		Diameter N	Length D	Diameter A max	Diameter B max	Armour wire size T	A/F F	A/C C	
TPBW20S-PACK-EN	2	20	10	11.8	15.8	0.90/1.25	22.0	24.4	16.0
TPBW20-PACK-EN	2	20	10	13.8	19.5	0.90/1.25	25.0	27.7	17.0
TPBW25-PACK-EN	2	25	10	19.8	27.0	1.25/1.60	33.0	36.6	18.0
TPBW32-PACK-EN	2	32	10	26.4	33.5	1.60/2.00	40.0	44.4	21.0
TPBW40-PACK-EN	1	40	15	32.4	40.1	1.60/2.00	48.0	53.3	23.0
TPBW50-PACK-EN	1	50	15	44.0	52.6	2.00/2.50	62.5	69.4	25.0
TPBW63-PACK-EN	1	63	15	56.2	65.5	2.50	76.0	84.4	28.0

All dimensions are in mm.

Pack content: Gland(s), shroud(s), EarthingNut™(s) and Crimp Connectors.

Packs are also available with Low-smoke LSF shroud or

Low Smoke Zero-halogen LSZH shroud -

Suffix above part numbers with either -LSF or -LSZH



See page 44 for more information on EarthingNuts™



## TBW RANGE

**60% QUICKER INSTALLATION**

Complete with the Award Winning EarthingNut™

Innovative Power Product of the Year

### Tauras™ BW Premier Range Brass Cable Gland Pack

#### 2 Part Indoor

Application: Brass indoor gland suitable for all types of steel wire armoured cable (SWA), providing mechanical cable retention and electrical continuity via armour wire termination.

Operating Temperature: -80°C to + 300°C Ingress Protection: IP2X

Approval: BS 6121 Part 1:2005

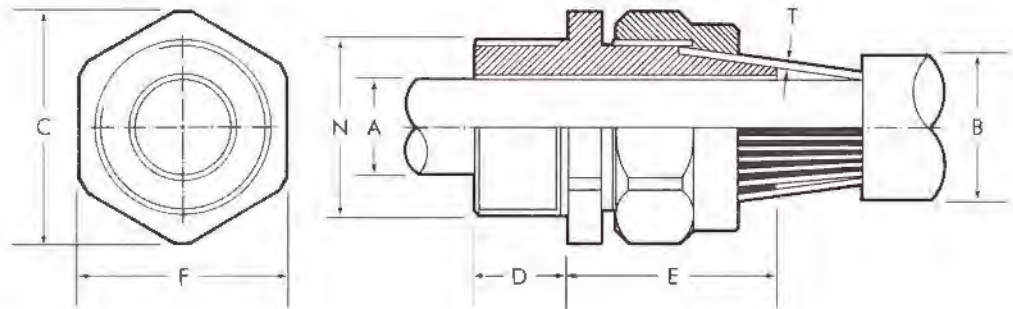

Part No.	Pack Quantity	Entry Thread		Cable Acceptance Details			Hexagonal Details		Assembled Length E
		Diameter N	Length D	Diameter A min max	Diameter B min max	Armour wire size T	A/F F	A/C C	
TBW20S PACK-EN	2	20	10	8.0 - 11.8	12.9 - 15.8	0.90/1.25	22.0	24.4	16.0
TBW20 PACK-EN	2	20	10	11.0 - 13.8	15.5 - 20.8	0.90/1.25	27.0	30.0	18.0
TBW25 PACK-EN	2	25	10	13.0 - 19.8	20.3 - 27.5	1.25/1.60	34.0	37.7	20.0
TBW32 PACK-EN	2	32	10	19.0 - 26.4	26.7 - 33.5	1.60/2.00	41.0	45.5	21.0
TBW40 PACK-EN	1	40	15	25.0 - 32.4	33.0 - 40.9	1.60/2.00	50.0	55.5	23.0
TBW50S PACK-EN	1	50	15	31.5 - 38.0	39.4 - 46.3	2.00/2.50	60.0	66.6	24.5
TBW50 PACK-EN	1	50	15	36.5 - 44.0	45.7 - 52.6	2.00/2.50	65.0	72.1	24.5
TBW63S PACK-EN	1	63	15	42.5 - 49.0	52.1 - 61.5	2.50	75.0	83.2	29.0
TBW63 PACK-EN	1	63	15	48.5 - 55.5	58.4 - 65.3	2.50	80.0	88.8	29.0
TBW75S PACK-EN	1	75	20	54.5 - 62.0	64.8 - 73.0	2.50	90.0	100.0	33.0
TBW75 PACK-EN	1	75	20	60.5 - 67.0	71.0 - 78.0	2.50	95.0	105.4	33.0
TBW90 PACK-EN	1	*90	20	66.0 - 79.0	77.0 - 90.0	2.50/3.15	106.0	117.6	37.0

All dimensions are in mm. \* Not included in BS 6121

Pack content: Gland(s), shroud(s), EarthingNut™(s) and Crimp Connectors.

Packs are also available with Low-smoke LSF shroud or Low Smoke Zero-halogen LSZH shroud - Suffix above part numbers with either -LSF or -LSZH





# TBWL RANGE

**60% QUICKER INSTALLATION**

Complete with the Award Winning EarthingNut™

Innovative Power Product of the Year



## Taurus™ BWL Premier Range Brass Cable Gland Pack

### 3 Part Indoor

**Application:** Brass indoor gland suitable for all types of steel wire armoured cable (SWA), providing mechanical cable retention and electrical continuity via armour wire termination and additional armour locking ring.

**Operating Temperature:** -80°C to +300°C **Ingress Protection:** IP2X EN60529

**Approval:** BS 6121 Part 1:2005

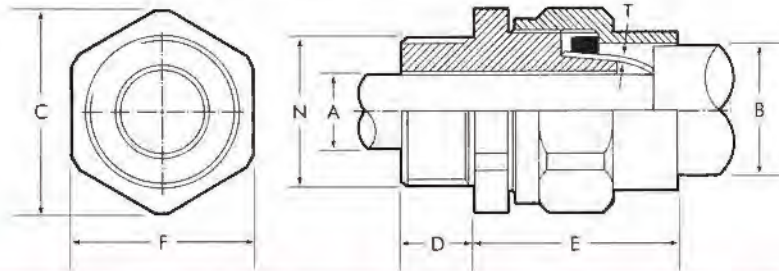

Part No.	Pack Quantity	Entry Thread		Cable Acceptance Details			Hexagonal Details		Assembled Length E
		Diameter N	Length D	Diameter A min max	Diameter B min max	Armour wire size T	A/F F	A/C C	
TBWL20S PACK-EN	2	20	10	8.0 - 11.8	12.9 - 15.8	0.90/1.25	24.0	26.6	26.0
TBWL20 PACK-EN	2	20	10	11.0 - 13.8	15.5 - 20.8	0.90/1.25	30.0	33.3	28.0
TBWL25 PACK-EN	2	25	10	13.0 - 19.8	20.3 - 27.5	1.25/1.60	36.0	42.2	30.0
TBWL32 PACK-EN	2	32	10	19.0 - 26.4	26.7 - 33.5	1.60/2.00	46.0	51.0	33.0
TBWL40 PACK-EN	1	40	15	25.0 - 32.4	33.0 - 40.9	1.60/2.00	55.0	61.0	35.0
TBWL50 PACK-EN	1	50	15	36.5 - 44.0	45.7 - 52.6	2.00/2.50	65.0	72.1	37.0
TBWL63 PACK-EN	1	63	15	48.5 - 55.5	58.4 - 65.3	2.50	80.0	88.8	43.0
TBWL75 PACK-EN	1	75	20	60.5 - 67.0	71.0 - 78.0	2.50	95.0	105.4	48.0

### Taurus™ BWL Long Thread Versions

TBWL20SLT PACK-EN	2	20	12	8.0 - 11.8	12.9 - 15.8	0.90/1.25	24.0	26.6	26.0
TBWL20LT PACK-EN	2	20	12	11.0 - 13.8	15.5 - 20.8	0.90/1.25	30.0	33.3	28.0
TBWL25LT PACK-EN	2	25	12	13.0 - 19.8	20.3 - 27.5	1.25/1.60	36.0	42.2	30.0
TBWL32LT PACK-EN	2	32	12	19.0 - 26.4	26.7 - 33.5	1.60/2.00	46.0	51.0	33.0
TBWL40LT PACK-EN	1	40	17	25.0 - 32.4	33.0 - 40.9	1.60/2.00	55.0	61.0	35.0
TBWL50LT PACK-EN	1	50	17	36.5 - 44.0	45.7 - 52.6	2.00/2.50	65.0	72.1	37.0
TBWL63LT PACK-EN	1	63	17	48.5 - 55.5	58.4 - 65.3	2.50	80.0	88.8	43.0
TBWL75LT PACK-EN	1	75	22	60.5 - 67.0	71.0 - 78.0	2.50	95.0	105.4	48.0

All dimensions are in mm.

Pack content: Gland(s), shroud(s), EarthingNut™(s) and Crimp Connectors.

Packs are also available with Low-smoke LSF shroud or Low Smoke Zero-halogen LSZH shroud - Suffix above part numbers with either -LSF or -LSZH



# TPCW RANGE

**60% QUICKER INSTALLATION**

Complete with the Award Winning EarthingNut™

Innovative Power Product of the Year

**Tauras™ PEX® CW Outdoor Brass Cable Gland Pack**  
with award-winning EarthingNut™

**Application:** Brass indoor and outdoor gland suitable for all types of steel wire armoured cable (SWA), providing an environmental seal on the outer cable sheath. The gland also provides mechanical cable retention and electrical continuity via armour wire termination.

**Operating Temperature (standard seals):** -20°C to +80°C

**Ingress Protection:** IP66

**Approval:** BS 6121 Part 1:2005



Scan to view the demo

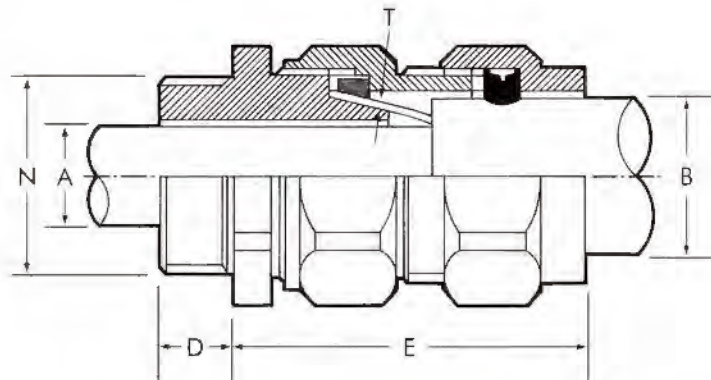
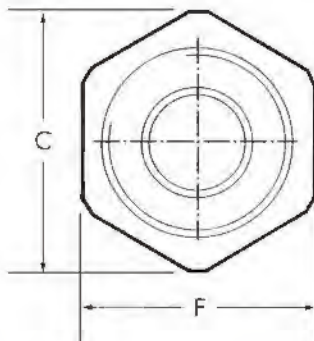

Part No.	Pack Quantity	Entry Thread		Cable Acceptance Details			Hexagonal Details				Assembled Length
		Diameter N	Length D	Diameter A min	Diameter B max	Armour Wire Size T	Body & Back Nut		Compression Nut		
							A/F F	A/C C	A/F J	A/C K	
TPCW20S-PACK-EN	2	20	10	8.0 - 11.8	12.9 - 15.8	0.90/1.25	23.0	25.6	24.0	26.7	38.0
TPCW20-PACK-EN	2	20	10	11.0 - 13.8	15.5 - 20.5	0.90/1.25	26.0	28.9	28.0	31.1	39.0
TPCW25-PACK-EN	2	25	10	13.0 - 20.0	20.3 - 27.0	1.25/1.60	34.0	37.7	35.5	39.5	45.0
TPCW32-PACK-EN	2	32	10	19.0 - 26.4	26.7 - 33.5	1.60/2.00	42.0	46.8	46.0	51.2	48.0
TPCW40-PACK-EN	1	40	15	25.0 - 32.4	33.0 - 40.1	1.60/2.00	50.0	55.7	55.0	61.0	53.0
TPCW50-PACK-EN	1	50	15	37.0 - 44.2	46.0 - 52.6	2.00/2.50	62.0	69.1	65.0	72.1	59.0
TPCW63-PACK-EN	1	63	15	48.0 - 56.2	58.4 - 65.3	2.50	76.0	84.7	80.0	88.8	66.0

All dimensions are in mm.

Pack content: Gland(s), shroud(s), EarthingNut™(s) and Crimp Connectors.

Packs are also available with Low-smoke LSF shroud or

Low Smoke Zero-halogen LSZH shroud -

Suffix above part numbers with either -LSF or -LSZH





# TCW RANGE

**60% QUICKER INSTALLATION**

Complete with the Award Winning EarthingNut™

Innovative Power Product of the Year



## Taurus™ CW Premier Range Brass Cable Gland Pack

### 4 Part Outdoor

Application: Brass indoor and outdoor gland suitable for all types of steel wire armoured cable (SWA), providing an environmental seal on the outer cable sheath. The gland also provides mechanical cable retention and electrical continuity via armour wire termination.

Operating Temperature (standard seals): -20°C to +80°C

Ingress Protection: IP66 EN60529



Approval: BS EN 62444 : 2013

Gland only available on request.

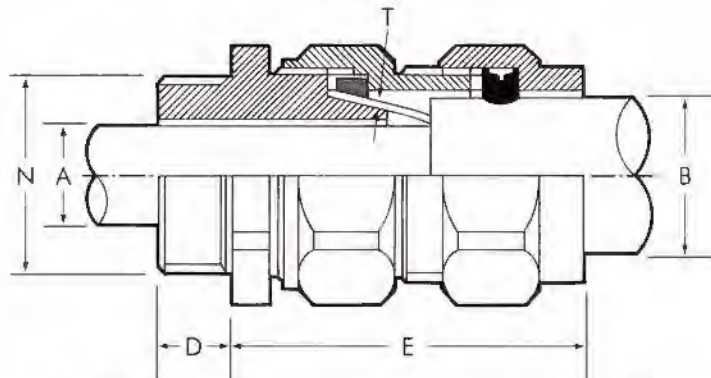
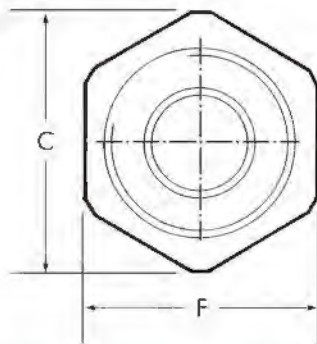

Part No.	Pack Quantity	Entry Thread		Cable Acceptance Details			Hexagonal Details		Assembled Length E
		Diameter N	Length D	Diameter A min max	Diameter B min max	Armour wire size T	A/F F	A/C C	
TCW20/16 PACK-EN	2	20	10	9.0	8.4 - 13.8	0.90	22.0	24.4	38.0
TCW20S PACK-EN	2	20	10	8.0 - 11.8	12.9 - 15.8	0.90/1.25	24.0	26.6	40.0
TCW20 PACK-EN	2	20	10	11.0 - 13.8	15.5 - 20.8	0.90/1.25	30.0	33.3	41.0
TCW25 PACK-EN	2	25	10	13.0 - 19.8	20.3 - 27.5	1.25/1.60	38.0	42.2	44.0
TCW32 PACK-EN	2	32	10	19.0 - 26.4	26.7 - 33.5	1.60/2.00	46.0	51.0	48.0
TCW40 PACK-EN	1	40	15	25.0 - 32.4	33.0 - 40.9	1.60/2.00	55.0	61.0	52.0
TCW50S PACK-EN	1	50	15	31.5 - 38.0	39.4 - 46.3	2.00/2.50	60.0	66.6	55.0
TCW50 PACK-EN	1	50	15	36.5 - 44.0	45.7 - 52.6	2.00/2.50	65.0	72.1	55.0
TCW63S PACK-EN	1	63	15	42.5 - 49.0	52.1 - 61.5	2.50	75.0	83.2	60.0
TCW63 PACK-EN	1	63	15	48.5 - 55.5	58.4 - 65.3	2.50	80.0	88.8	60.0
TCW75S PACK-EN	1	75	20	54.5 - 62.0	64.8 - 73.0	2.50	90.0	100.0	65.0
TCW75 PACK-EN	1	75	20	60.5 - 67.0	71.0 - 78.0	2.50	95.0	105.4	65.0
TCW90 PACK-EN	1	*90	20	66.0 - 79.0	77.0 - 90.0	2.50/3.15	110.0	122.1	70.0

All dimensions are in mm. \*Not included in BS 6121

Pack content: Gland(s), shroud(s), EarthingNut™(s) and Crimp Connectors.

Packs are also available with Low-smoke LSF shroud or Low Smoke Zero-halogen LSZH shroud - Suffix above part numbers with either -LSF or -LSZH



# TE1W RANGE

**60% QUICKER INSTALLATION**

Complete with the Award Winning EarthingNut™

Innovative Power Product of the Year



## Taurus™ E1W Premier Range Brass Cable Gland Pack

Application: Brass indoor and outdoor gland suitable for all types of steel wire armoured cable (SWA), providing an environmental seal on both the cable inner and outer sheaths. The gland also provides mechanical cable retention and electrical continuity via armour wire termination.

Operating Temperature (standard seals): -20°C to +80°C

Ingress Protection: IP66 EN60529

Approval: BS EN 62444 : 2013



Gland only available on request.

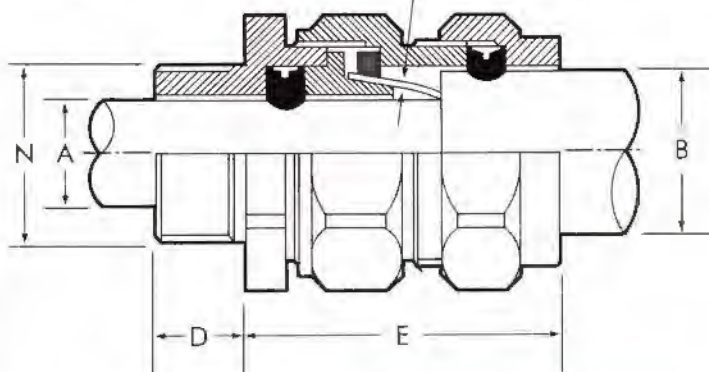
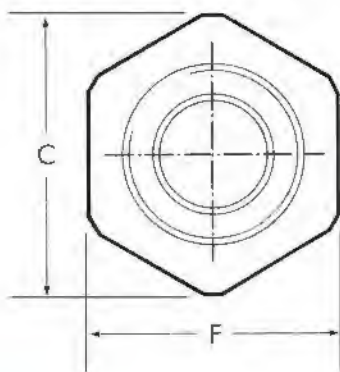

Part No.	Pack Quantity	Entry Thread		Cable Acceptance Details			Hexagonal Details		Assembled Length E
		Diameter N	Length D	Diameter A	Diameter B	Armour wire size T	A/F	A/C	
							F	C	
TE1W20/16 PACK-EN	2	20	15	3.5 - 9.0	8.4 - 13.8	0.90	22.0	24.4	40.0
TE1W20S PACK-EN	2	20	15	8.0 - 11.8	12.9 - 15.8	0.90/1.25	24.0	26.6	42.0
TE1W20 PACK-EN	2	20	15	11.0 - 13.8	15.5 - 20.0	0.90/1.25	30.0	33.3	43.0
TE1W25 PACK-EN	2	25	15	13.0 - 19.8	20.3 - 27.5	1.25/1.60	38.0	42.2	46.0
TE1W32 PACK-EN	2	32	15	19.0 - 26.4	26.7 - 33.5	1.60/2.00	46.0	51.0	50.0
TE1W40 PACK-EN	1	40	20	25.0 - 32.4	33.0 - 40.9	1.60/2.00	55.0	61.0	54.5
TE1W50S PACK-EN	1	50	20	31.5 - 38.0	39.4 - 46.3	2.00/2.50	60.0	66.6	57.5
TE1W50 PACK-EN	1	50	20	36.5 - 44.0	45.7 - 52.6	2.00/2.50	65.0	72.1	57.5
TE1W63S PACK-EN	1	63	20	42.5 - 49.0	52.1 - 61.5	2.50	75.0	83.2	63.0
TE1W63 PACK-EN	1	63	20	48.5 - 55.5	58.4 - 65.3	2.50	80.0	88.8	63.0
TE1W75S PACK-EN	1	75	20	54.5 - 62.0	64.8 - 73.0	2.50	90.0	100.0	68.0
TE1W75 PACK-EN	1	75	20	60.5 - 67.0	71.0 - 78.0	2.50	95.0	105.4	68.0

All dimensions are in mm.

Pack content: Gland(s), shroud(s), EarthingNut™(s) and Crimp Connectors.

Packs are also available with Low-smoke LSF shroud or

Low Smoke Zero-halogen LSZH shroud -

Suffix above part numbers with either -LSF or -LSZH





# TE1FW RANGE

**60% QUICKER INSTALLATION**

Complete with the Award Winning EarthingNut™  
Innovative Power Product of the Year



## Taurus™ E1FW Premier Range Brass Cable Gland Pack

**Hazardous Areas**



Application: Dual certified flameproof Ex d and Increased Safety Ex e indoor and outdoor cable gland for use in Zone 1, Zone 2, Zone 21 and Zone 22 hazardous areas with all types of circular armoured cable, providing a flameproof seal on the cable outer sheath.

Gland must be used as part of a certified assembly in surface installations only. Gland may not be used on a group IIC Ex d Enclosure that is larger than 2000cc volume.

Certification: ITS11ATEX17453X (For Ex d & Ex e)

Operating Temperature: -20°C to +100°C

Ingress Protection: IP67

Degree of Protection: IEC 60529

Electrical Apparatus Use in Dust Zone 21 & 22: EN 60079-31:2009

Code of Protection Category: II 2 GD, Ex d IIC Gb / Ex e IIC Gb -20°C to +100°C,

Ex tb IIIC -20°C to +100°C Db IP67, Equipment Zone 1, Zone 2, Zone 21 and Zone 22. Gas Groups IIA, IIB, IIC

Compliance Standards: EN 60079-0:2009, IEC 60079-0:2011, EN 60079-1:2007 & EN 60079-7:2007

Cable Type: Wire Armour, Steel Wire Armoured

Sealing Area(s): Outer sheath of both the cables A & B (inner & outer sheath)

Sealing Material: Polyamide / PTFE

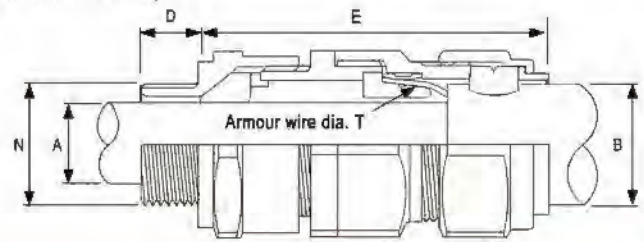
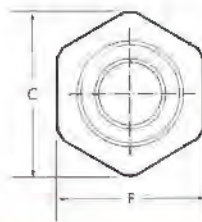

Part No.	Entry Threads Dia. Length N D		Cable Acceptance Diameter								Armour Wire Dia. T	Hex. Details - Body, Body Lock, & GN		Hex. Details Compression Nut		Assembled Length Approx.	
			Cable A				Cable B					A/F F	A/C C	A/F F	A/C C	Comp. E	Uncomp. E
			RR Without Min.	RR With Max.	RR Without Min.	RR With Max.	RR Without Min.	RR With Max.	RR Without Min.	RR With Max.							
TE1FW20/16 PACK-EN	M20x1.5	16.5	3.5	6.0	5.9	8.5	8.4	10.8	10.7	13.2	0.90	22.0	24.4	24.0	26.6	55.0	70.0
TE1FW20S PACK-EN	M20x1.5	16.5	8.0	9.75	9.65	11.5	12.9	14.4	14.3	15.8	0.90/1.25	24.0	26.6	26.0	28.8	59.0	74.0
TE1FW20 PACK-EN	M20x1.5	16.5	11.0	12.25	12.15	13.5	15.5	18.2	18.1	20.8	0.90/1.25	30.0	33.3	32.0	35.5	64.0	81.0
TE1FW25 PACK-EN	M25x1.5	16.5	13.0	16.25	16.15	19.5	20.3	23.8	23.7	27.2	1.25/1.60	38.0	42.2	41.0	45.5	71.0	91.0
TE1FW32 PACK-EN	M32x1.5	16.5	19.0	22.25	22.15	25.5	26.7	30.1	30.0	33.5	1.60/2.00	46.0	51.1	48.0	53.3	77.0	100.0
TE1FW40 PACK-EN	M40x1.5	22.0	25.0	28.50	28.40	32.0	33.0	36.5	36.4	39.9	1.60/2.00	55.0	61.1	57.0	63.3	83.0	108.0
TE1FW50S PACK-EN	M50x1.5	22.0	31.5	34.25	34.15	37.0	39.4	42.9	42.8	46.3	2.00/2.50	60.0	66.6	62.0	68.9	91.0	116.0
TE1FW50 PACK-EN	M50x1.5	22.0	36.5	39.75	39.15	43.0	45.7	49.2	49.1	52.6	2.00/2.50	68.0	75.5	70.0	77.7	91.0	116.0
TE1FW63S PACK-EN	M63x1.5	22.0	42.5	46.25	46.15	50.0	52.1	55.5	55.4	58.9	2.50	75.0	83.3	78.0	86.6	100.0	126.0
TE1FW63 PACK-EN	M63x1.5	22.0	48.5	51.75	51.65	55.0	58.4	61.9	61.8	65.3	2.50	80.0	88.8	85.0	94.4	100.0	126.0

All dimensions are in mm.

Pack content: Gland(s), shroud(s), EarthingNut™(s) and Crimp Connectors.

Packs are also available with Low-smoke LSF shroud or Low Smoke Zero-halogen LSZH shroud - Suffix above part numbers with either -LSF or -LSZH



## Cable Glands



### PEX® BW Commercial Brass Cable Gland Pack

#### 2 Part Indoor

**Application:** Brass indoor gland suitable for all types of steel wire armoured cable (SWA), providing mechanical cable retention and electrical continuity via armour wire termination.

**Operating Temperature:** -80°C to + 300°C

**Ingress Protection:** IP2X EN60529

**Approval:** BS 6121 Part 1:2005

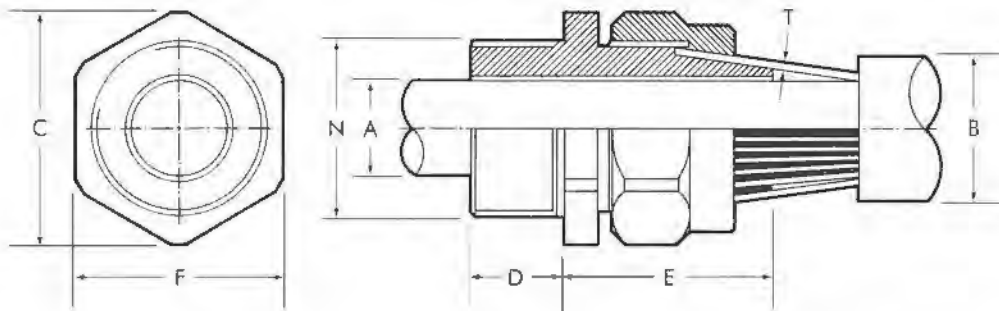

Part No.	Pack Quantity	Entry Thread		Cable Acceptance Details			Hexagonal Details		Assembled Length
		Diameter N	Length D	Diameter A max	Diameter B max	Armour wire size T	A/F F	A/C C	
PBW20S PACK	2	20	10	11.8	15.8	0.90/1.25	22.0	24.4	16.0
PBW20 PACK	2	20	10	13.8	19.5	0.90/1.25	25.0	27.7	17.0
PBW25 PACK	2	25	10	19.8	27.0	1.25/1.60	33.0	36.6	18.0
PBW32 PACK	2	32	10	26.4	33.5	1.60/2.00	40.0	44.4	21.0
PBW40 PACK	1	40	15	32.4	40.1	1.60/2.00	48.0	53.3	23.0
PBW50S PACK	1	50	15	38.0	46.3	2.00/2.50	56.0	62.2	24.0
PBW50 PACK	1	50	15	44.0	52.6	2.00/2.50	62.5	69.4	25.0
PBW63S PACK	1	63	15	49.0	61.5	2.50	70.0	77.7	26.0
PBW63 PACK	1	63	15	56.2	65.5	2.50	76.0	84.4	28.0
PBW75S PACK	1	75	15	62.0	71.6	2.50	85.0	94.4	36.0

All dimensions are in mm.

Pack content: Gland(s), steel locknut(s), earth tag(s) and shroud(s).

Packs are also available with Low-smoke LSF shroud or

Low Smoke Zero-halogen LSZH shroud -

Suffix above part numbers with either -LSF or -LSZH



See page 44 for EarthingNut™ Information.



## PEX® CW Commercial Brass Cable Gland Pack

### 4 Part Outdoor



**Application:** Brass indoor and outdoor 4 part cable gland suitable for all types of steel wire armoured cable (SWA), providing an environmental seal on the outer cable sheath. The gland also provides mechanical cable retention and electrical continuity via armour wire termination.

**Operating Temperature (standard seals):** -20°C to +80°C

**Ingress Protection:** IP66 EN60529

**Approval:** BS EN 62444 : 2013

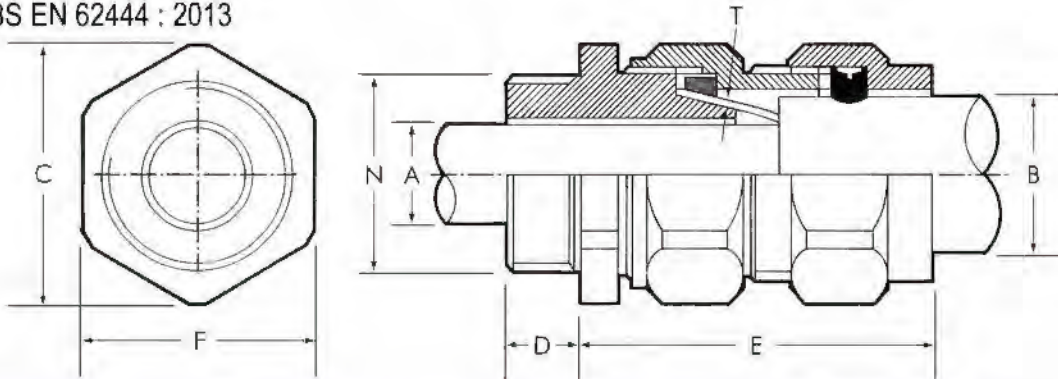

Part No.	Pack Quantity	Entry Thread		Cable Acceptance Details			Hexagonal Details				Assembled Length
		Diameter N	Length D	Diameter A max	Diameter B min max	Armour Wire Size T	Body & Back Nut A/F F	A/C C	Compression Nut A/F J	A/C K	
PCW20S PACK	2	20	10	11.8	12.9 - 15.8	0.90/1.25	23.0	25.6	24.0	26.7	38.0
PCW20 PACK	2	20	10	13.8	15.5 - 20.5	0.90/1.25	26.0	28.9	28.0	31.1	39.0
PCW25 PACK	2	25	10	19.8	20.3 - 27.0	1.25/1.60	34.0	37.7	35.5	39.5	45.0
PCW32 PACK	2	32	10	26.4	26.7 - 33.5	1.60/2.00	42.0	46.8	46.0	51.2	48.0
PCW40 PACK	1	40	15	32.4	33.0 - 40.1	1.60/2.00	50.0	55.7	55.0	61.0	53.0
PCW50S PACK	1	50	15	38.0	39.8 - 46.3	2.00/2.50	62.0	69.1	65.0	72.4	59.0
PCW50 PACK	1	50	15	44.0	46.0 - 52.6	2.00/2.50	62.0	69.1	65.0	72.1	59.0
PCW63S PACK	1	63	15	49.0	52.3 - 61.5	2.50	76.0	84.7	80.0	89.2	66.0
PCW63 PACK	1	63	15	55.5	58.4 - 65.3	2.50	76.0	84.7	80.0	88.8	66.0

All dimensions are in mm.

Pack content: Gland(s), steel locknut(s), earth tag(s) and shroud(s).

Packs are also available with Low-smoke LSF shroud or

Low Smoke Zero-halogen LSZH shroud -

Suffix above part numbers with either -LSF or -LSZH



See page 44 for EarthingNut™ Information.

## BW Premier Range Brass Cable Gland Pack

### 2 Part Indoor



Application: Brass indoor gland suitable for all types of steel wire armoured cable (SWA), providing mechanical cable retention and electrical continuity via armour wire termination.

Operating Temperature: -80°C to +300°C

Ingress Protection: IP2X EN60529

Approval: BS 6121 Part 1:2005

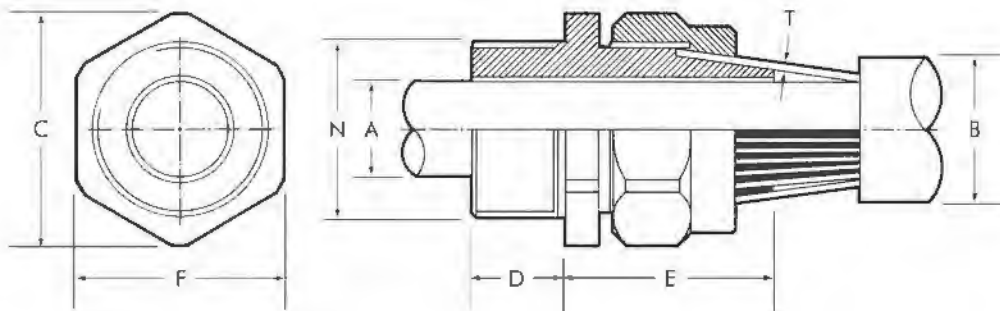

Part No.	Pack Quantity	Entry Thread		Cable Acceptance Details			Hexagonal Details		Assembled Length
		Diameter N	Length D	Diameter A min max	Diameter B min max	Armour wire size T	A/F F	A/C C	
BW20S PACK	2	20	10	8.0 - 11.8	12.9 - 15.8	0.90/1.25	22.0	24.4	16.0
BW20 PACK	2	20	10	11.0 - 13.8	15.5 - 20.8	0.90/1.25	27.0	30.0	18.0
BW25 PACK	2	25	10	13.0 - 19.8	20.3 - 27.5	1.25/1.60	34.0	37.7	20.0
BW32 PACK	2	32	10	19.0 - 26.4	26.7 - 33.5	1.60/2.00	41.0	45.5	21.0
BW40 PACK	1	40	15	25.0 - 32.4	33.0 - 40.9	1.60/2.00	50.0	55.5	23.0
BW50S PACK	1	50	15	31.5 - 38.0	39.4 - 46.3	2.00/2.50	60.0	66.6	24.5
BW50 PACK	1	50	15	36.5 - 44.0	45.7 - 52.6	2.00/2.50	65.0	72.1	24.5
BW63S PACK	1	63	15	42.5 - 49.0	52.1 - 61.5	2.50	75.0	83.2	29.0
BW63 PACK	1	63	15	48.5 - 55.5	58.4 - 65.3	2.50	80.0	88.8	29.0
BW75S PACK	1	75	20	54.5 - 62.0	64.8 - 73.0	2.50	90.0	100.0	33.0
BW75 PACK	1	75	20	60.5 - 67.0	71.0 - 78.0	2.50	95.0	105.4	33.0
BW90 PACK	1	*90	20	66.0 - 79.0	77.0 - 90.0	2.50/3.15	106.0	117.6	37.0

All dimensions are in mm. \* Not included in BS 6121

Pack content: Gland(s), steel locknut(s), earth tag(s) and shroud(s).

Packs are also available with Low-smoke LSF shroud or Low Smoke Zero-halogen LSZH shroud - Suffix above part numbers with either -LSF or -LSZH



# Cable Glands

## BWL Premier Range Brass Cable Gland Pack

### 3 Part Indoor

Application: Brass indoor gland suitable for all types of steel wire armoured cable (SWA), providing mechanical cable retention and electrical continuity via armour wire termination and additional armour locking ring.

Operating Temperature: -80°C to +300°C Ingress Protection: IP2X EN60529

Approval: BS 6121 Part 1:2005

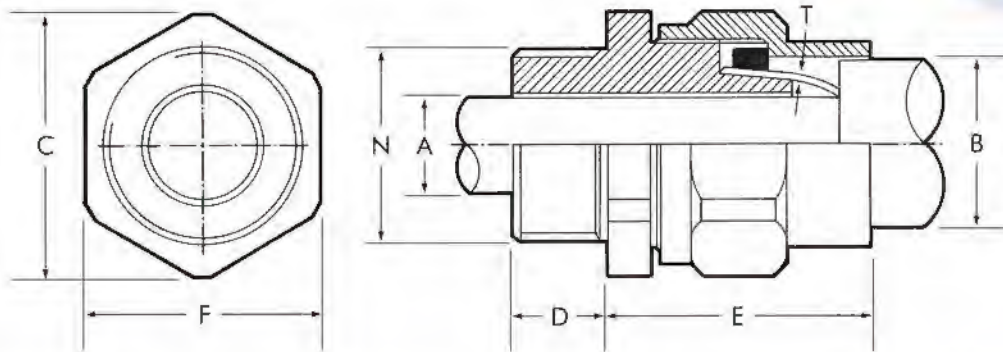

Part No.	Pack Quantity	Entry Thread		Cable Acceptance Details			Hexagonal Details		Assembled Length
		Diameter N	Length D	Diameter A min max	Diameter B min max	Armour wire size T	A/F F	A/C C	
BWL20S PACK	2	20	10	8.0 - 11.8	12.9 - 15.8	0.90/1.25	24.0	26.6	26.0
BWL20 PACK	2	20	10	11.0 - 13.8	15.5 - 20.8	0.90/1.25	30.0	33.3	28.0
BWL25 PACK	2	25	10	13.0 - 19.8	20.3 - 27.5	1.25/1.60	36.0	42.2	30.0
BWL32 PACK	2	32	10	19.0 - 26.4	26.7 - 33.5	1.60/2.00	46.0	51.0	33.0
BWL40 PACK	1	40	15	25.0 - 32.4	33.0 - 40.9	1.60/2.00	55.0	61.0	35.0
BWL50 PACK	1	50	15	36.5 - 44.0	45.7 - 52.6	2.00/2.50	65.0	72.1	37.0
BWL63 PACK	1	63	15	48.5 - 55.5	58.4 - 65.3	2.50	80.0	88.8	43.0
BWL75 PACK	1	75	20	60.5 - 67.0	71.0 - 78.0	2.50	95.0	105.4	48.0

### BWL Long Thread Versions

BWL20SLT PACK	2	20	12	8.0 - 11.8	12.9 - 15.8	0.90/1.25	24.0	26.6	26.0
BWL20LT PACK	2	20	12	11.0 - 13.8	15.5 - 20.8	0.90/1.25	30.0	33.3	28.0
BWL25LT PACK	2	25	12	13.0 - 19.8	20.3 - 27.5	1.25/1.60	36.0	42.2	30.0
BWL32LT PACK	2	32	12	19.0 - 26.4	26.7 - 33.5	1.60/2.00	46.0	51.0	33.0
BWL40LT PACK	1	40	17	25.0 - 32.4	33.0 - 40.9	1.60/2.00	55.0	61.0	35.0
BWL50LT PACK	1	50	17	36.5 - 44.0	45.7 - 52.6	2.00/2.50	65.0	72.1	37.0
BWL63LT PACK	1	63	17	48.5 - 55.5	58.4 - 65.3	2.50	80.0	88.8	43.0
BWL75LT PACK	1	75	22	60.5 - 67.0	71.0 - 78.0	2.50	95.0	105.4	48.0

All dimensions are in mm.

Pack content: Gland(s), steel locknut(s), earth tag(s) and shroud(s).

Packs are also available with Low-smoke LSF shroud or Low Smoke Zero-halogen LSZH shroud - Suffix above part numbers with either -LSF or -LSZH



# Cable Glands

## CW Premier Brass Cable Gland Pack

### 4 Part Outdoor



Application: Brass indoor and outdoor gland suitable for all types of steel wire armoured cable (SWA), providing an environmental seal on the outer cable sheath. The gland also provides mechanical cable retention and electrical continuity via armour wire termination.

Operating Temperature (standard seals): -20°C to +80°C

Ingress Protection: IP66 EN60529 Approval: BS EN 62444 : 2013

Gland only available on request.

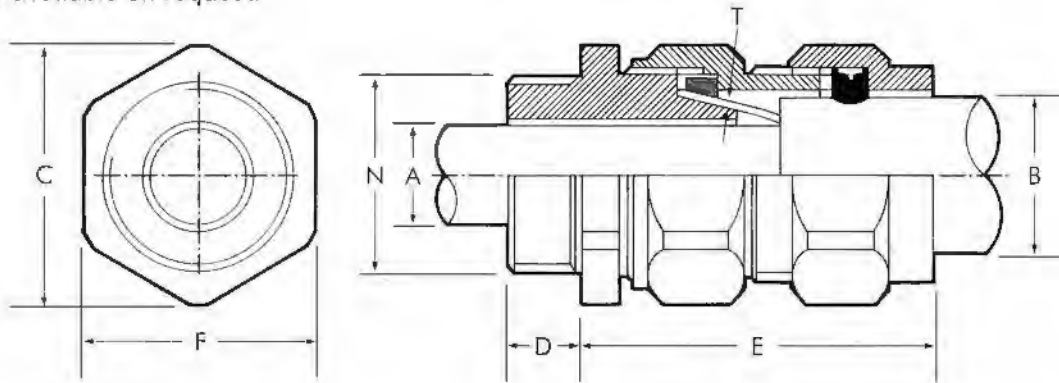

Part No.	Pack Quantity	Entry Thread		Cable Acceptance Details			Hexagonal Details		Assembled Length
		Diameter N	Length D	Diameter A min max	Diameter B min max	Armour wire size T	A/F F	A/C C	
<b>CW20/16 PACK</b>	2	20	10	9.0	8.4 - 13.8	0.90	22.0	24.4	38.0
<b>CW20S PACK</b>	2	20	10	8.0 - 11.8	12.9 - 15.8	0.90/1.25	24.0	26.6	40.0
<b>CW20 PACK</b>	2	20	10	11.0 - 13.8	15.5 - 20.8	0.90/1.25	30.0	33.3	41.0
<b>CW25 PACK</b>	2	25	10	13.0 - 19.8	20.3 - 27.5	1.25/1.60	38.0	42.2	44.0
<b>CW32 PACK</b>	2	32	10	19.0 - 26.4	26.7 - 33.5	1.60/2.00	46.0	51.0	48.0
<b>CW40 PACK</b>	1	40	15	25.0 - 32.4	33.0 - 40.9	1.60/2.00	55.0	61.0	52.0
<b>CW50S PACK</b>	1	50	15	31.5 - 38.0	39.4 - 46.3	2.00/2.50	60.0	66.6	55.0
<b>CW50 PACK</b>	1	50	15	36.5 - 44.0	45.7 - 52.6	2.00/2.50	65.0	72.1	55.0
<b>CW63S PACK</b>	1	63	15	42.5 - 49.0	52.1 - 61.5	2.50	75.0	83.2	60.0
<b>CW63 PACK</b>	1	63	15	48.5 - 55.5	58.4 - 65.3	2.50	80.0	88.8	60.0
<b>CW75S PACK</b>	1	75	20	54.5 - 62.0	64.8 - 73.0	2.50	90.0	100.0	65.0
<b>CW75 PACK</b>	1	75	20	60.5 - 67.0	71.0 - 78.0	2.50	95.0	105.4	65.0
<b>CW90 PACK</b>	1	*90	20	66.0 - 79.0	77.0 - 90.0	2.50/3.15	110.0	122.1	70.0

All dimensions are in mm. \*Not included in BS 6121

Pack content: Gland(s), steel locknut(s), earth tag(s) and shroud(s).

Packs are also available with Low-smoke LSF shroud or Low Smoke Zero-halogen LSZH shroud - Suffix above part numbers with either -LSF or -LSZH

# Cable Glands

## E1W Premier Range Brass Cable Gland Pack



CE

Application: Brass indoor and outdoor gland suitable for all types of steel wire armoured cable (SWA), providing an environmental seal on both the cable inner and outer sheaths. The gland also provides mechanical cable retention and electrical continuity via armour wire termination.

Operating Temperature (standard seals): -20°C to +80°C

Ingress Protection: IP66 EN60529

Approval: BS EN 62444 : 2013

Gland only available on request.

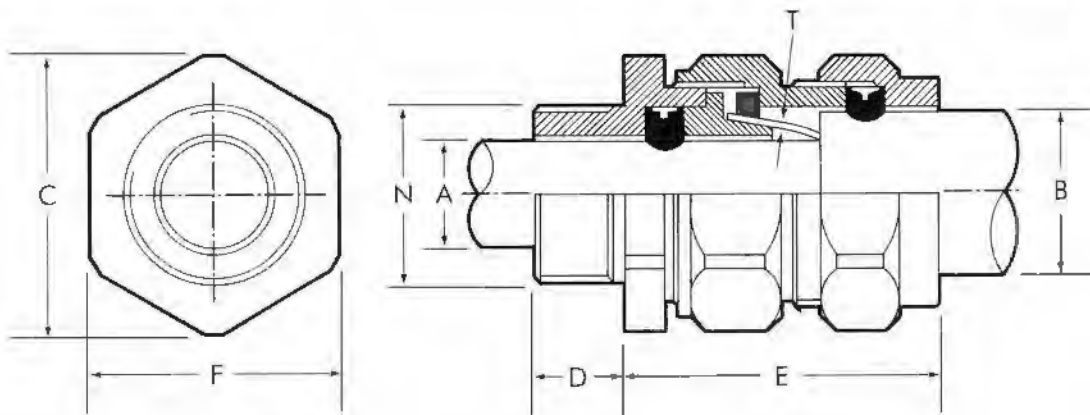

Part No.	Pack Quantity	Entry Thread		Cable Acceptance Details			Hexagonal Details		Assembled Length E
		Diameter N	Length D	Diameter A min max	Diameter B min max	Armour wire size T	A/F F	A/C C	
E1W20/16 PACK	2	20	15	3.5 - 9.0	8.4 - 13.8	0.90	22.0	24.4	40.0
E1W20S PACK	2	20	15	8.0 - 11.8	12.9 - 15.8	0.90/1.25	24.0	26.6	42.0
E1W20 PACK	2	20	15	11.0 - 13.8	15.5 - 20.0	0.90/1.25	30.0	33.3	43.0
E1W25 PACK	2	25	15	13.0 - 19.8	20.3 - 27.5	1.25/1.60	38.0	42.2	46.0
E1W32 PACK	2	32	15	19.0 - 26.4	26.7 - 33.5	1.60/2.00	46.0	51.0	50.0
E1W40 PACK	1	40	20	25.0 - 32.4	33.0 - 40.9	1.60/2.00	55.0	61.0	54.5
E1W50S PACK	1	50	20	31.5 - 38.0	39.4 - 46.3	2.00/2.50	60.0	66.6	57.5
E1W50 PACK	1	50	20	36.5 - 44.0	45.7 - 52.6	2.00/2.50	65.0	72.1	57.5
E1W63S PACK	1	63	20	42.5 - 49.0	52.1 - 61.5	2.50	75.0	83.2	63.0
E1W63 PACK	1	63	20	48.5 - 55.5	58.4 - 65.3	2.50	80.0	88.8	63.0
E1W75S PACK	1	75	20	54.5 - 62.0	64.8 - 73.0	2.50	90.0	100.0	68.0
E1W75 PACK	1	75	20	60.5 - 67.0	71.0 - 78.0	2.50	95.0	105.4	68.0

All dimensions are in mm.

Pack content: Gland(s), steel locknut(s), earth tag(s) and shroud(s).

Packs are also available with Low-smoke LSF shroud or

Low Smoke Zero-halogen LSZH shroud -

Suffix above part numbers with either -LSF or -LSZH



See page 44 for more information on EarthingNuts™

## GXD Premier Range Brass Cable Gland Pack For Braided Type Cable



CE

Application: Brass indoor and outdoor gland suitable for all types of flexible wire braided cable such as CY and SY. The gland provides an environmental seal on the cable outer sheath and internal mechanical retention of wire braid for electrical continuity. Gland complete with steel locknuts and brass washers.

Operating Temperature (standard seals): -20°C to +80°C

Ingress Protection: IP66 EN60529

Approval: BS EN 62444:2013

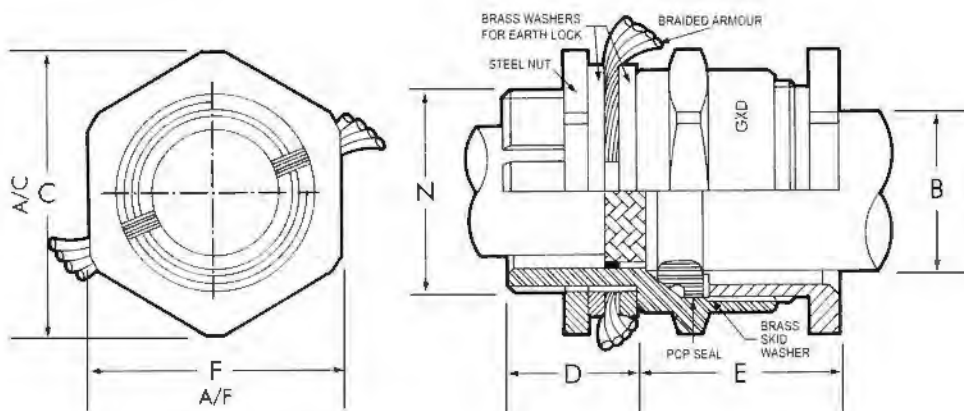

Part No.	Pack Quantity	Entry Thread		Cable Acceptance Details		Hexagonal Details		Assembled Length
		Diameter N	Length D	Minimum B	Maximum B	A/F F	A/C C	
GXD20S PACK	2	20	15	7.0	11.6	24.0	26.9	18.0
GXD20 PACK	2	20	15	10.5	13.6	27.0	30.0	20.0
GXD25 PACK	2	25	15	12.5	19.8	36.0	40.3	26.0
GXD32 PACK	2	32	15	18.5	26.3	41.0	45.6	26.0
GXD40 PACK	1	40	15	25.0	32.1	50.0	55.8	27.0
GXD50S PACK	1	50	15	30.5	38.1	55.0	61.5	27.0
GXD50 PACK	1	50	15	36.5	44.0	60.0	67.0	27.0

All dimensions are in mm.

Other sizes available on request.

Pack content: Gland(s), locknut(s), shroud(s) and brass washer(s).

Accessories available: Earth Tags and Entry Washers.

## A2 Brass Cable Gland Pack

CE

Application: Brass indoor and outdoor industrial gland suitable for all types of unarmoured cable, providing a seal on the outer sheath.

Operating Temperature (standard seals): -20°C to +80°C

Ingress Protection: IP66 EN60529

Approval: BS EN 62444 : 2013

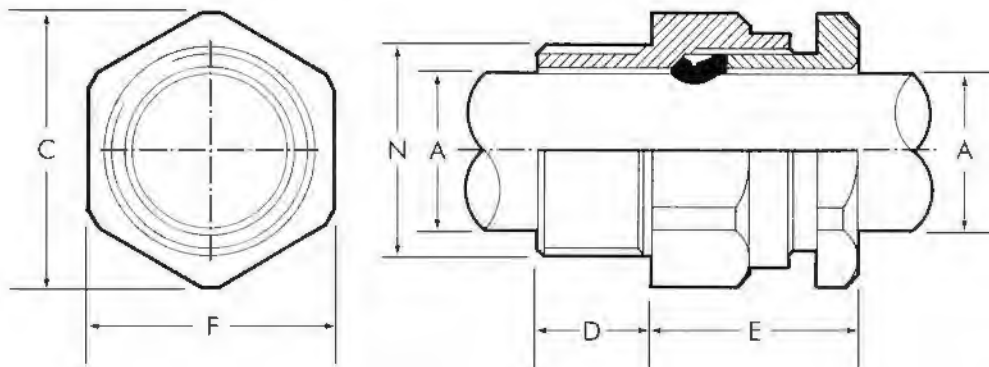

Part No.	Pack Quantity	Entry Thread		Cable Acceptance Details		Hexagonal Details		Assembled Length
		Diameter N	Length D	Minimum A	Maximum A	A/F F	A/C C	
<b>A2/2016 PACK</b>	2	20	12	3.5	9.0	17.0	18.8	17.0
<b>A2/20S PACK</b>	2	20	12	8.0	11.8	19.0	21.0	18.0
<b>A2/20 PACK</b>	2	20	12	11.0	13.8	21.0	23.3	18.0
<b>A2/25 PACK</b>	2	25	12	13.0	19.8	27.0	30.0	20.0
<b>A2/32 PACK</b>	2	32	12	19.0	26.4	35.0	38.8	24.0
<b>A2/40 PACK</b>	1	40	15	25.0	32.4	42.0	46.6	27.0
<b>A2/50S PACK</b>	1	50	15	31.5	38.0	50.0	55.5	28.0
<b>A2/50 PACK</b>	1	50	15	37.0	43.5	55.0	61.0	28.0
<b>A2/63S PACK</b>	1	63	15	42.5	49.0	63.0	70.0	30.0
<b>A2/63 PACK</b>	1	63	15	48.5	55.5	70.0	77.7	30.0
<b>A2/75S PACK</b>	1	75	15	54.5	62.0	75.0	83.2	32.0
<b>A2/75 PACK</b>	1	75	15	60.5	67.0	80.0	88.8	32.0
<b>A2/90 PACK*</b>	1	90	15	70.0	79.0	95.0	105.4	34.0

All dimensions are in mm. \*Not included in BS 6121

Pack content: Gland(s), steel locknut(s) and shroud(s).

# Hazardous Area Cable Glands

## E1FW-RC Premier Range (Reversible Cone)

**Hazardous Areas**



**Application:** Dual certified flameproof Ex d and Increased Safety Ex e indoor and outdoor cable gland for use in Zone 1, Zone 2, Zone 21 and Zone 22 hazardous areas with all types of circular armoured cable, braided SY cables and steel tape armoured cables providing a flameproof seal on the cable outer sheath. Gland features Reversible Cone to suit all applications.

*Gland must be used as part of a certified assembly in surface installations only. Gland may not be used on a group IIC Ex d Enclosure that is larger than 2000cc volume.*

**Certification:** Group II, Category-2 (zone 1) gas group IIC confirm to EBN 60079-0:2009 & EN 60079-1:2007.

**Electrical Apparatus** for use in dust Zone 21 & 22 as per EN 60079-31:2009.

**Degree of protection:** IP67 as per EN 60529:1991

**Material:** Material of construction of cable gland is BRASS/SS304/SS316/MS

Brass: BS 2874 CZ121 / IS 319 gr.1 / SS: ASTM A314 gr. 304/304

**Threads:** Isometric (ISO) ISO:965 - 1 & 965 - 3, BS:3643

**Operating Temperature:** The cable sealing washer (elastomeric sealing ring) used and is suitable for operating temperature -20°C to +100°C

**Note:** The cable glands are suitable for SWA (Steel Wire Armoured), steel tape armoured and braid wire cable. 'W' refer to the wire diameter in a steel tape armoured cable.

'XYZ' - refer to the wire diameter in a steel tape armoured cable or braid wire cable.

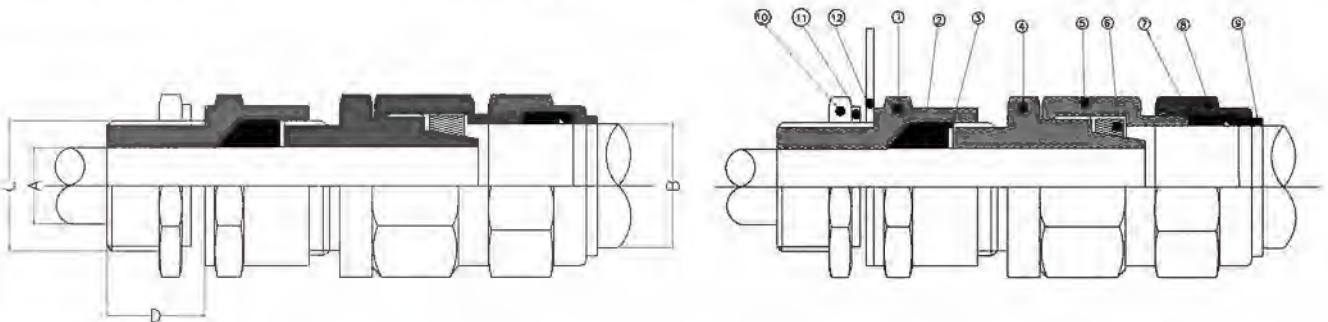

### Specification

Name	Part Name	Material	Name	Part Name	Material
1	Gland Body	Brass	7	Outer Sealing	NBR
2	Inner Sealing	NBR	8	Cable Nut	Brass
3	Inner Washer	Brass	9	Protection Tube	Nylon
4	Ring Body	Brass	10	Lock Nut	Brass
5	Body	Brass	11	Thread Seals	Nylon
6	Armoured Ring	Brass	12	Earth Tag	Brass

SWA Part No.	Pack Qty	Entry Threads		Thread Length 'D'		Cable Dimen. (mm)				Armour Acceptance Range	
		Metric (ISO)	ET	Metric (ISO)	ET	Cable Diam. (A) Min.	Cable Diam. (A) Max.	Cable Diam. (B) Min.	Cable Diam. (B) Max.	W	XYZ
E1FW20S PACK-RC	2	M20	15	16.5	6.1	11.6	9.5	15.9	0.90/1.25	0.15/0.35	
E1FW20 PACK-RC	2	M20	15	16.5	6.5	13.9	12.5	20.9	0.90/1.25	0.15/0.50	
E1FW25 PACK-RC	2	M25	15	16.5	11.1	19.9	17	26.2	1.25/1.60	0.15/0.50	
E1FW32 PACK-RC	2	M32	15	16.5	17	26.2	22.9	33.9	1.60/2.00	0.15/0.55	

All measurements are in mm.

Pack content: Gland(s), brass locknut(s), earth tag(s), and shroud(s).



TEL: (44) 01453 844333 | FAX: (44) 01453 842224 | E-MAIL: sales@swaonline.co.uk

# Hazardous Area Cable Glands



## E1FW Premier Range Brass Cable Gland Pack

**Hazardous Areas** CE  $\text{Ex}$

Application: Dual certified flameproof Ex d and Increased Safety Ex e indoor and outdoor cable gland for use in Zone 1, Zone 2, Zone 21 and Zone 22 hazardous areas with all types of circular armoured cable, providing a flameproof seal on the cable outer sheath.

Gland must be used as part of a certified assembly in surface installations only. Gland may not be used on a group IIC Ex d Enclosure that is larger than 2000cc volume.

Certification: ITS11ATEX17453X (For Ex d & Ex e)

Operating Temperature: -20°C to +100°C

Ingress Protection: IP67

Degree of Protection: IEC 60529

Electrical Apparatus Use in Dust Zone 21 & 22: EN 60079-31:2009

Code of Protection Category: II 2 GD, Ex d IIC Gb / Ex e IIC Gb -20°C to +100°C,

Ex tb IIC -20°C to +100°C Db IP67, Equipment Zone 1, Zone 2, Zone 21 and Zone 22. Gas Groups IIA, IIB, IIC

Compliance Standards: EN 60079-0:2009, IEC 60079-0:2011, EN 60079-1:2007 & EN 60079-7:2007

Cable Type: Wire Armour, Steel Wire Armoured

Sealing Area(s): Outer sheath of both the cables A & B (inner & outer sheath)

Sealing Material: Polyamide/PTFE

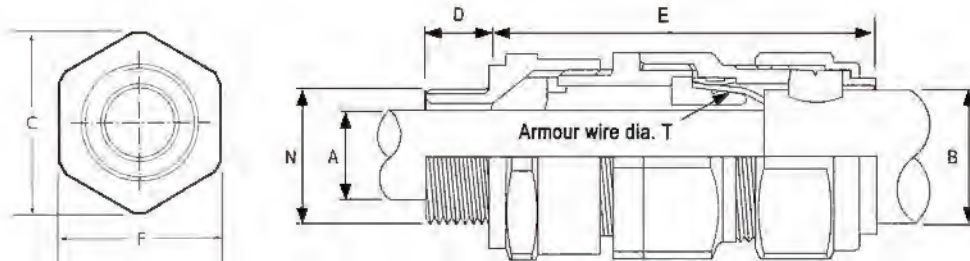

Part No.	Entry Threads Dia. Length N D		Cable Acceptance Diameter								Armour Wire Dia. T	Hex. Details - Body, Body Lock, & GN		Hex. Details Compression Nut		Assembled Length Approx.	
			Cable A				Cable B					A/F F	A/C C	A/F F	A/C C	Comp. E	Uncomp. E
			RR Without Min.	RR With Max.	RR Without Min.	RR With Max.	RR Without Min.	RR With Max.	RR Without Min.	RR With Max.							
<b>E1FW16 PACK</b>	M16x1.5	16.5	3.5	6.0	5.9	8.5	8.4	10.8	10.7	13.2	0.90	22.0	24.4	24.0	26.6	55.0	70.0
<b>E1FW20/16 PACK</b>	M20x1.5	16.5	3.5	6.0	5.9	8.5	8.4	10.8	10.7	13.2	0.90	22.0	24.4	24.0	26.6	55.0	70.0
<b>E1FW20S PACK</b>	M20x1.5	16.5	8.0	9.75	9.65	11.5	12.9	14.4	14.3	15.8	0.90/1.25	24.0	26.6	26.0	28.8	59.0	74.0
<b>E1FW20 PACK</b>	M20x1.5	16.5	11.0	12.25	12.15	13.5	15.5	18.2	18.1	20.8	0.90/1.25	30.0	33.3	32.0	35.5	64.0	81.0
<b>E1FW25 PACK</b>	M25x1.5	16.5	13.0	16.25	16.15	19.5	20.3	23.8	23.7	27.2	1.25/1.60	38.0	42.2	41.0	45.5	71.0	91.0
<b>E1FW32 PACK</b>	M32x1.5	16.5	19.0	22.25	22.15	25.5	26.7	30.1	30.0	33.5	1.60/2.00	46.0	51.1	48.0	53.3	77.0	100.0
<b>E1FW40 PACK</b>	M40x1.5	22.0	25.0	28.50	28.40	32.0	33.0	36.5	36.4	39.9	1.60/2.00	55.0	61.1	57.0	63.3	83.0	108.0
<b>E1FW50S PACK</b>	M50x1.5	22.0	31.5	34.25	34.15	37.0	39.4	42.9	42.8	46.3	2.00/2.50	60.0	66.6	62.0	68.9	91.0	116.0
<b>E1FW50 PACK</b>	M50x1.5	22.0	36.5	39.75	39.15	43.0	45.7	49.2	49.1	52.6	2.00/2.50	68.0	75.5	70.0	77.7	91.0	116.0
<b>E1FW63S PACK</b>	M63x1.5	22.0	42.5	46.25	46.15	50.0	52.1	55.5	55.4	58.9	2.50	75.0	83.3	78.0	86.6	100.0	126.0
<b>E1FW63 PACK</b>	M63x1.5	22.0	48.5	51.75	51.65	55.0	58.4	61.9	61.8	65.3	2.50	80.0	88.8	85.0	94.4	100.0	126.0

All measurements are in mm.

Pack content: Gland(s), brass locknut(s), earth tag(s), and shroud(s).

Hazardous Area Cable Glands



# Hazardous Area Cable Glands



## E1FX Premier Range Brass Cable Gland Pack

**Hazardous Areas** CE Ex

**Application:** Dual certified flameproof Ex d and Increased Safety Ex e indoor and outdoor cable gland for use in Zone 1, Zone 2, Zone 21 and Zone 22 hazardous areas with all types of flexible wire braided cable, providing a flameproof seal on the cable outer sheath.

*Gland must be used as part of a certified assembly in surface installations only. Gland may not be used on a group IIC Ex d Enclosure that is larger than 2000cc volume.*

**Certification:** ITS11ATEX17453X (For Ex d & Ex e)

**Operating Temperature:** -20°C to +100°C

**Ingress Protection:** IP67

**Degree of Protection:** IEC 60529

**Electrical Apparatus Use in Dust Zone 21 & 22:** EN 60079-31:2009

**Code of Protection Category:** II 2 GD, Ex d IIC Gb / Ex e IIC Gb -20°C to +100°C,

Ex tb IIIC -20°C to +100°C Db IP67, Equipment Zone 1, Zone 2, Zone 21 and Zone 22. Gas Groups IIA, IIB, IIC

**Compliance Standards:** EN 60079-0:2009, IEC 60079-0:2011, EN 60079-1:2007 & EN 60079-7:2007

**Cable Type:** Flexible Wire Braided

**Sealing Area(s):** Outer Sheath of both the cables A & B (inner & outer)

**Sealing Material:** Polyamide/PTFE

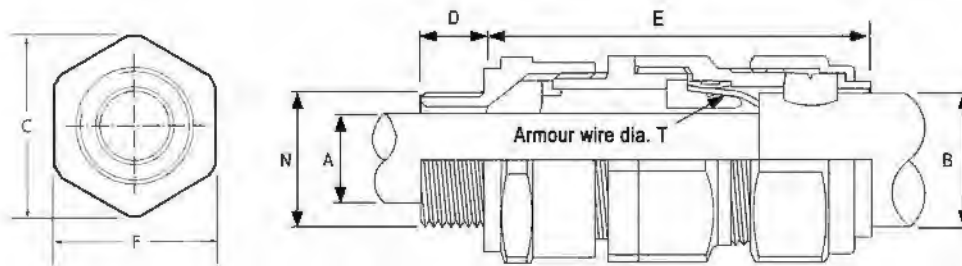

Part No.	Entry Threads		Cable Acceptance Diameter								Armour Wire Dia. T	Hex. Details - Body, Body Lock, & GN		Hex. Details Compression Nut		Assembled Length Approx.	
	Dia. N	Length D	Cable A				Cable B					A/F	A/C	A/F	A/C	Comp. E	Uncomp. E
			RR Without Min.	RR With Max.	RR Without Min.	RR With Max.	RR Without Min.	RR With Max.									
<b>E1FX16 PACK</b>	M16x1.5	16.5	3.5	6.0	5.9	8.5	8.4	10.8	10.7	13.2	0.90	22.0	24.4	24.0	26.6	55.0	70.0
<b>E1FX20/16 PACK</b>	M20x1.5	16.5	3.5	6.0	5.9	8.5	8.4	10.8	10.7	13.2	0.90	22.0	24.4	24.0	26.6	55.0	70.0
<b>E1FX20S PACK</b>	M20x1.5	16.5	8.0	9.75	9.65	11.5	12.9	14.4	14.3	15.8	0.90/1.25	24.0	26.6	26.0	28.8	59.0	74.0
<b>E1FX20 PACK</b>	M20x1.5	16.5	11.0	12.25	12.15	13.5	15.5	18.2	18.1	20.8	0.90/1.25	30.0	33.3	32.0	35.5	64.0	81.0
<b>E1FX25 PACK</b>	M25x1.5	16.5	13.0	16.25	16.15	19.5	20.3	23.8	23.7	27.2	1.25/1.60	38.0	42.2	41.0	45.5	71.0	91.0
<b>E1FX32 PACK</b>	M32x1.5	16.5	19.0	22.25	22.15	25.5	26.7	30.1	30.0	33.5	1.60/2.00	46.0	51.1	48.0	53.3	77.0	100.0
<b>E1FX40 PACK</b>	M40x1.5	22.0	25.0	28.50	28.40	32.0	33.0	36.5	36.4	39.9	1.60/2.00	55.0	61.1	57.0	63.3	83.0	108.0
<b>E1FX50S PACK</b>	M50x1.5	22.0	31.5	34.25	34.15	37.0	39.4	42.9	42.8	46.3	2.00/2.50	60.0	66.6	62.0	68.9	91.0	116.0
<b>E1FX50 PACK</b>	M50x1.5	22.0	36.5	39.75	39.15	43.0	45.7	49.2	49.1	52.6	2.00/2.50	68.0	75.5	70.0	77.7	91.0	116.0

All measurements are in mm.

Pack content: Gland(s), brass locknut(s), earth tag(s), and shroud(s).



# Hazardous Area Cable Glands

## A2F Premier Range Brass Cable Gland Pack

**Hazardous Areas**

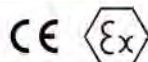

Application: Dual certified flameproof Ex d and Increased Safety Ex e indoor and outdoor cable gland for use of in Zone 1, Zone 2, Zone 21 and Zone 22 hazardous areas with all types of circular unarmoured cable, providing a flameproof seal on the cable outer sheath.

Gland must be used as part of a certified assembly in surface installations only. Gland may not be used on a group IIC Ex d Enclosure that is larger than 2000cc volume.

Certification: ITS11 ATEX 17453X (For Ex d & Ex e)

Operating Temperature: -20°C to +100°C

Ingress Protection: IP67

Degree of Protection: IEC 60529

Electrical Apparatus Use in Dust Zone 21 & 22: EN 60079-31:2009

Code of Protection Category: II 2 GD, Ex d IIC Gb / Ex e IIC Gb -20°C to +100°C,

Ex tb IIIC -20°C to +100°C Db IP67, Equipment Zone 1, Zone 2, Zone 21 and Zone 22. Gas Groups IIA, IIB, IIC

Compliance Standards: EN 60079-0:2009, IEC 60079-0:2011, EN 60079-1:2007 & EN 60079-7:2007

Cable Type: Unarmoured, SWA Extruded Bending Cable

Sealing Area(s): Outer Sheath

Sealing Material: Polyamide/PTFE

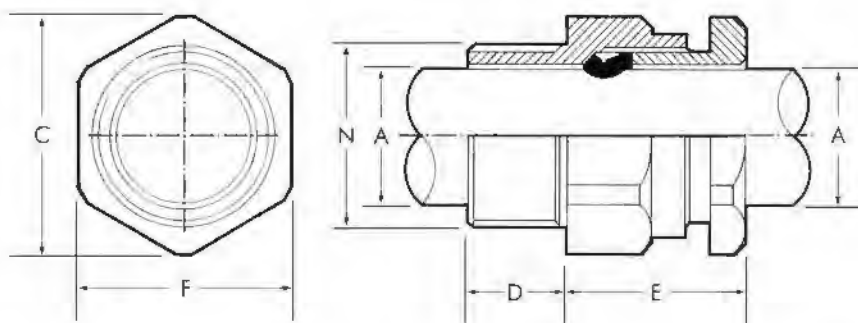

Part No	Entry Threads		Cable Acceptance Diameter Cable A				Hexagonal Details Body		Hexagonal Details Compression Nut		Assembled Length	
	Dia. N	Length D	Rubber Ring Small Min.	Rubber Ring Small Max.	Rubber Ring Large Min.	Rubber Ring Large Max.	A/F F	A/C C	A/F F	A/C C	Comp. E	Uncomp. E
<b>A2F16 PACK</b>	M16 x 1.5	16.5	3.5	6.0	5.9	8.5	20.0	22.2	22.0	24.4	22.0	26.0
<b>A2F20/16 PACK</b>	M20 x 1.5	16.5	3.5	6.0	5.9	8.5	20.0	22.2	22.0	24.4	22.0	26.0
<b>A2F20S PACK</b>	M20 x 1.5	16.5	8.0	9.75	9.65	11.5	22.0	24.4	24.0	26.7	25.0	29.5
<b>A2F20 PACK</b>	M20 x 1.5	16.5	11.0	12.25	12.15	13.5	26.0	28.9	27.0	30.0	28.0	33.0
<b>A2F25 PACK</b>	M25 x 1.5	16.5	13.0	16.25	16.15	19.5	32.0	35.5	34.0	37.8	34.0	40.8
<b>A2F32 PACK</b>	M32 x 1.5	16.5	19.0	22.25	22.15	25.5	41.0	45.5	43.0	47.8	34.0	41.5
<b>A2F40 PACK</b>	M40 x 1.5	22.0	25.0	28.50	28.40	32.0	48.0	53.3	50.0	55.5	36.0	45.0
<b>A2F50S PACK</b>	M50 x 1.5	22.0	31.5	34.25	34.15	37.0	55.0	61.1	57.0	63.3	36.0	45.0
<b>A2F50 PACK</b>	M50 x 1.5	22.0	36.5	39.75	39.15	43.0	62.0	68.9	65.0	72.2	36.0	45.0
<b>A2F63S PACK</b>	M63 x 1.5	22.0	42.5	46.25	46.15	50.0	70.0	77.7	75.0	83.3	38.0	48.0
<b>A2F63 PACK</b>	M63 x 1.5	22.0	48.5	51.75	51.65	55.0	75.0	83.2	80.0	88.8	38.0	48.0

All dimensions are in mm.

Pack content: Gland(s), steel locknut(s) and shroud(s).

Hazardous Area Cable Glands



TEL: (44) 01453 844333 | FAX: (44) 01453 842224 | E-MAIL: sales@swaonline.co.uk

# Hazardous Area Cable Glands

## A2FB Premier Range Brass Cable Gland Pack

**Hazardous Areas**



Application: Dual certified flameproof Ex d and Increased Safety Ex e indoor and outdoor cable gland for use in Zone 1, Zone 2, Zone 21 and Zone 22 hazardous areas with all types of circular unarmoured cable, providing a flameproof seal on the cable outer sheath.

Gland must be used as part of a certified assembly in surface installations only. Gland may not be used on a group IIC Ex d Enclosure that is larger than 2000cc volume.

Approved by: IMQ

Certification: IMQ 11 ATEX 038X

Temperature Classes: -30°C / +120°C with NBR Sealing Ring;  
 -40°C / +100°C with NEOPRENE Sealing Ring;  
 -60°C / +180°C with SILICONE Sealing Ring

Safety Requirements: EN 60079-0:2009 / EN 60079-1:2007 / EN 60079-7:2007 / EN 60079-11:2010 / EN 60079-31:2009

Equipment Marking: Flameproof Ex-d and Increased Safety Ex-e EX II 2GD Ex d IIC Gb / Exe IIC Gb

Suitable for use in: Zone 1, Zone 2, Zone 21, Zone 22 for Gas Groups IIA, IIB, IIC for Gas & Dust potentially explosive atmospheres

Degree of Protection: IP66-IP68 (EN 60529)

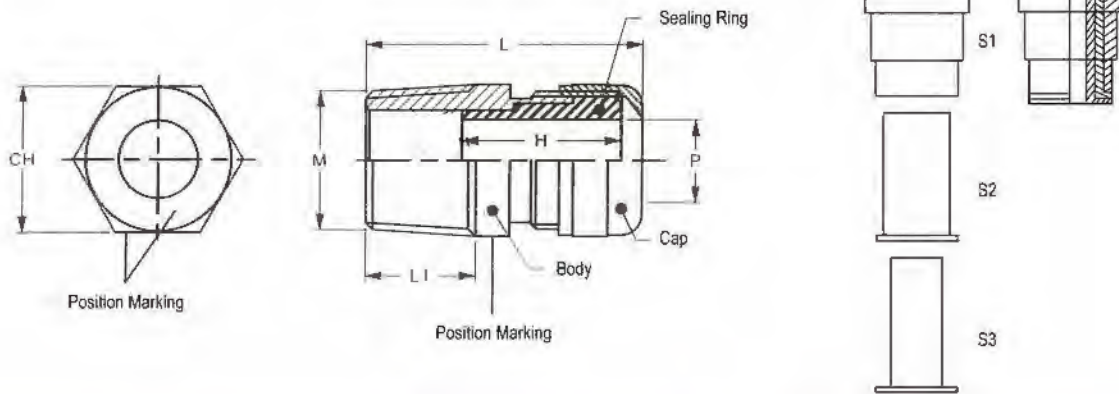

Part No	Entry Thread ISO pitch	Pack Quantity	Dimensions				∅ Sealing Ring Dimension		Sealing Combinations		
			L	L1 mi	CH	H min	Min	Max	S1+S2+S3	S1+S2	S1
A2FB20S PACK	M20 x 1.5	2	40	16	22	20	3.0	12.0	3-6	6-9	9-12
A2FB20 PACK	M20 x 1.5	2	45	16	28	20	10.0	16.0		10-13	13-16
A2FB25 PACK	M25 x 1.5	2	50	16	35	25	14.0	20.0	14-17	17-20	
A2FB32S PACK	M32 x 1.5	2	43	16	35	25	14.0	24.0	14-17	17-20	20-24
A2FB32 PACK	M32 x 1.5	2	53	16	45	39	22.0	28.0		22-26	26-28
A2FB40 PACK	M40 x 1.5	1	45	18	45	39	22.0	32.0		22-26	26-32
A2FB50S PACK	M50 x 1.5	1	46	18	55/50	32	26.0	35.0		26-30	30-35
A2FB50 PACK	M50 x 1.5	1	63	18	55/58	38	35.0	44.0		35-38	38-44

All dimensions are in mm.

Pack content: Gland(s), steel locknut(s) and shroud(s).

## Cable Gland Accessories

### Entry Thread Washers

To maintain the IP rating of the equipment and gland it may be necessary to fit an entry thread washer at the gland interface.

Part No.		To Fit Thread Size
Nylon	Fibre	
<b>M16NW</b>	<b>M16FW</b>	M16
<b>M20NW</b>	<b>M20FW</b>	M20
<b>M25NW</b>	<b>M25FW</b>	M25
<b>M32NW</b>	<b>M32FW</b>	M32
<b>M40NW</b>	<b>M40FW</b>	M40
<b>M50NW</b>	<b>M50FW</b>	M50
<b>M63NW</b>	<b>M63FW</b>	M63
<b>M75NW</b>	<b>M75FW</b>	M75



Fibre



Nylon

### Serrated 'Shakeproof' Washers

Internal serrated washers, manufactured from mild steel, are used on cable gland entry threads to dampen the vibrations of the cable gland or equipment assembly which may loosen the cable gland or locknut.

Manufactured to suit thread specification Isometric (ISO) to BS3643:1981

Zinc plated and stainless steel available to order.

Part No.	To Fit Thread Size
<b>M20SW</b>	M20
<b>M25SW</b>	M25
<b>M32SW</b>	M32
<b>M40SW</b>	M40
<b>M50SW</b>	M50
<b>M63SW</b>	M63



### Brass Reducers and Adapters

SWA brass adaptors and reducers provide an effective method of connection between dissimilar threads or sizes. Reducers reduce the thread entry diameter of an enclosure to accept a gland or fitting with a smaller or alternative thread. It should be noted that no more than one adaptor or reducer should be used at any one time.

Increased safety versions also available - suffix part numbers EExe



Ordering details:

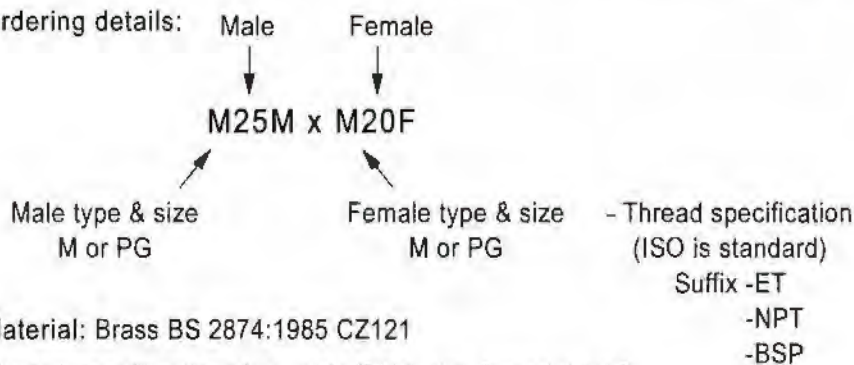

Material: Brass BS 2874:1985 CZ121

Thread specification: Isometric (ISO), PG, Imperial (ET), National Pipe Thread (NPT), British Standard Pipe (BSP)

ISO Metric Thread World-wide most commonly used type thread

Characterized by its major diameter and its pitch

Designated by the letter M followed by the value of the nominal diameter and the pitch, both expressed in millimetres and separated by the multiplication sign 'x'

NPT Thread = National Pipe Thread

Taper rate for all NPT threads is 1/16

The taper on NPT threads allows them to form a seal when torqued as the flanks of the threads compress against each other, as opposed to straight thread fittings

PG Thread = Panzer-Gewinde (also Panzer-Rohr-Gewinde) German thread type

Depth of thread smaller than NPT or Metric, but larger flank angle



Brass Reducer



Brass Adaptor

# Hazardous Area Cable Gland Accessories

## Brass Stopping Plugs

**Material:** Brass BS 2874:1985 CZ121

This material is classified as a component and is therefore not given a temperature rating.

The SWA range of stopping plugs are designed to close any unused entries in electrical equipment without revoking existing certification.

The range covers three design types:



**Tamperproof**

Inserted from the outside with the allen key towards the enclosure and then tightened from the inside to leave a flush finish to prevent unauthorised removal.



**Allen Key Type**

Inserted with the allen key pointing away from the box and tightened from the outside.



**Hexagonal Head Type**

Hexagon headed plugs are inserted from the outside and fastened by means of a spanner.

Tamperproof	Part No. Allen key	Hexagon head	Thread	Allen key	Hex. head A/F mm
SP-M16T	SP-M16A	SP-M16H	M16	6	19.0
SP-M20T	SP-M20A	SP-M20H	M20	10	23.3
SP-M25T	SP-M25A	SP-M25H	M25	10	28.0
SP-M32T	SP-M32A	SP-M32H	M32	10	37.5
SP-M40T	SP-M40A	SP-M40H	M40	10	47.0
SP-M50T	SP-M50A	SP-M50H	M50	10	56.0
SP-M63T	SP-M63A	SP-M63H	M63	10	70.0
SP-M75T	SP-M75A	SP-M75H	M75	10	80.0

EExe and EExd versions available: suffix above part numbers - **EExe** or **EExd**

Nylon stopping plugs now also available.

Plugs should be inserted directly into the unused entry and not into a thread reducer or thread adaptor.

## Nylon Stopping Plugs

EX Metric nylon (PBT) EExe II certified stopping plugs.

**Material:** PBT (Polybutylene Terephthalate)

**IP Ratings:** IP66/68 (with sealing washer)

**Standards:** ATEX Category 2, Category 3, II 2GD EExe e 11

Zones 1, 2, 21 & 22 EEx e IIC. DIP A21



SWA Part No.	Size	Allen Key	Hex Head A/F
SP-M20AN-EEXE	M20	10	23
SP-M25AN-EEXE	M25	10	28

# Cable Gland Accessories

## EarthingNut™

See page 44 for innovative EarthingNut™ range



Scan to view the demo

## Brass Earth Tags

Part No.	Size (mm)	Screw Hole Size
ET20	20	7.8
ET25	25	7.8
ET32	32	7.8
ET40	40	7.8
ET50	50	7.8
ET63	63	12.6
ET75	75	12.6

Manufactured in brass. Also available in aluminium and copper.



## Lock Nuts

Part No.		To suit thread size (mm) 1.5mm pitch
Steel	Brass	
SLN20	BLN20	20
SLN25	BLN25	25
SLN32	BLN32	32
SLN40	BLN40	40
SLN50	BLN50	50
SLN63	BLN63	63
SLN75	BLN75	75



Brass



Steel

## Dip Moulded PVC Shrouds

Part No.		Size (mm)
BW Glands	CW Glands	
SH20S	SHCW20S	20
SH20	SHCW20	20
SH25	SHCW25	25
SH32	SHCW32	32
SH40	SHCW40	40
SH50	SHCW50	50
SH63	SHCW63	63
SH75	SHCW75	75

## Low Smoke (LSF) Shrouds

## Zero Halogen (LSZH) Shrouds

Part No. Low Smoke	Part No. Zero Halogen	Size (mm)
SH20S-LSF	SH20S-LSZH	20
SH20-LSF	SH20-LSZH	20
SH25-LSF	SH25-LSZH	25
SH32-LSF	SH32-LSZH	32
SH40-LSF	SH40-LSZH	40
SH50-LSF	SH50-LSZH	50
SH63-LSF	SH63-LSZH	63
SH75-LSF	SH75-LSZH	75



Shroud



LSF Shroud







LSZH Shroud

# Cable Gland Sizing Charts

## Cable Gland Sizing Charts

XLPE / PVC / SWA - BS 4567

CABLE GLAND

Conductor Size (mm <sup>2</sup> )	No. of Cores	Approx. Overall Diameter (mm)									
			BW	TPBW & PBW	CW	TPCW & PCW	E1W	E1FW	E1FW-RC		
1.5	2	12.3	20S	20S	20/16	20S	20/16	20/16	20S		
	3	12.8			20S		20S				
	4	14.0			20S		20S				
	5	14.2			20S		20S				
	6	15.2			20S		20S				
	7	15.6			20S		20S				
2.5	2	13.6	20S	20S	20S	20S	20S	20S	20S		
	3	13.6	20S	20S	20S	20S	20S	20S	20S		
	4	14.7	20	20	20	20	20	20	20		
	5	16.3	20	20	20	20	20	20	20		
	6	17.1	20	20	20	20	20	20	20		
	7	17.6	20	20	20	20	20	20	20		
4	2	14.7	20	20	20S	20S	20S	20S	20S		
	3	15.3			20S	20S	20S	20S	20S		
	4	16.4			20	20	20	20	20		
	5	18.9			20	20	20	20	20		
6	2	15.9	20	20	20	20	20	20S	20S		
	3	16.6						20	20		
	4	18.7						20	20		
	5	20.5						25	25		
10	2	18.0	20	25	20	20	20	20	20		
	3	18.9								20	20
	4	20.3								25	25
	5	22.0								25	25
16	2	20.0	25	25	25	25	25	25	25		
	3	21.2								25	25
	4	22.9								25	25
	5	28.1								32	32

Due to cable diameter variances between manufacturers, we strongly advise the cable diameter is checked where possible, prior to purchasing the products.

# Cable Gland Sizing Charts

## Cable Gland Sizing Charts

XLPE / PVC / SWA - BS 4567





CABLE GLAND

Conductor Size (mm <sup>2</sup> )	No. of Cores	Approx. Overall Diameter (mm)										
			BW	TPBW & PBW	CW	TPCW & PCW	E1W	E1FW	E1FW-RC			
25	2	24.1	25	25	25	25	25	25	25			
	3	26.7	32		32					32	32	32
	4	28.9		32		32						
	5	31.0		32								
35	2	27.9		32	32	32	32	32	32			
	3	29.9	32									
	4	32.1			40							
	5	35.0	40									
50	2	25.8	32	25	25	25	25	25				
	3	28.5							32	32		
	4	32.0		40							50S	40
	5	40.0							40			
70	2	29.0	32	32	32	32	32	32				
	3	32.2							40	40		
	4	37.7		50S							N/A	50S
	5	43.3							50S			
95	2	33.1	32	32	32	32	32	32				
	3	37.0							40	40		
	4	41.7		50S							N/A	50S
	5	52.0							50			
120	2	36.1	40	40	40	40	40	40				
	3	40.4		N/A					50S			
	4	47.1		50								
150	2	39.3	40	40	40	40	40	40				
	3	45.5							50	50	50S	50
	4	51.4										

Due to cable diameter variances between manufacturers, we strongly advise the cable diameter is checked where possible, prior to purchasing the products.

# Cable Gland Sizing Charts

## Cable Gland Sizing Charts

XLPE / PVC / SWA - BS 4567			CABLE GLAND						
Conductor Size (mm <sup>2</sup> )	No. of Cores	Approx. Overall Diameter (mm)							
			BW	TPBW & PBW	CW	TPCW & PCW	E1W	E1FW	E1FW-RC
185	2	44.7	50S	50	50S	50	50S	50	N/A
	3	49.8	50		50		50		
	4	56.6	63S		63		63S		
240	2	49.0	50	63	50	N/A	50	63	N/A
	3	55.1	63S		63S		63S		
	4	63.0	63		63		63		
300	2	53.5	63S	N/A	63S	N/A	63S	63	N/A
	3	60.2	63	63	63		63		
	4	68.8	75S	75S	75S		N/A		
400	2	59.0	63S	63	63S	N/A	63	63	N/A
	3	66.6	75S	75S	75S		75S		
	4	78.1	90	N/A	90		75		

Due to cable diameter variances between manufacturers, we strongly advise the cable diameter is checked where possible, prior to purchasing the products.



# Cable Gland Sizing Charts

## Cable Gland Sizing Charts



GXD

E1FW20 PACK RC

### SY PVC Signal and Control Cables

Size mm <sup>2</sup> & No. of Cores	Nom. Dia. mm	GXD Gland Ref.	E1FW-RC Gland Ref.
0.5 x 2	7.1	GXD20S PACK	N/A
0.5 x 3	7.6	GXD20S PACK	N/A
0.5 x 4	8.0	GXD20S PACK	N/A
0.5 x 5	8.5	GXD20S PACK	N/A
0.5 x 7	9.3	GXD20S PACK	E1FW20S PACK-RC
0.5 x 12	11.5	GXD20 PACK	E1FW20S PACK-RC
0.5 x 18	13.4	GXD20 PACK	E1FW20S PACK-RC
0.5 x 25	15.8	GXD25 PACK	E1FW20S PACK-RC
0.75 x 2	7.6	GXD20S PACK	N/A
0.75 x 3	7.8	GXD20S PACK	N/A
0.75 x 4	8.3	GXD20S PACK	N/A
0.75 x 5	8.9	GXD20S PACK	N/A
0.75 x 7	9.7	GXD20S PACK	E1FW20S PACK-RC
0.75 x 12	12.2	GXD20 PACK	E1FW20S PACK-RC
0.75 x 18	13.6	GXD25 PACK	E1FW20S PACK-RC
0.75 x 25	16.7	GXD25 PACK	E1FW20 PACK-RC
1.0 x 2	8.2	GXD20S PACK	N/A
1.0 x 3	8.4	GXD20S PACK	N/A
1.0 x 4	8.8	GXD20S PACK	N/A
1.0 x 5	9.3	GXD20S PACK	N/A
1.0 x 7	9.9	GXD20S PACK	E1FW20S PACK-RC
1.0 x 12	12.5	GXD20 PACK	E1FW20S PACK-RC
1.0 x 18	14.5	GXD25 PACK	E1FW20S PACK-RC
1.0 x 25	17.9	GXD25 PACK	E1FW20 PACK-RC
1.5 x 2	8.5	GXD20S PACK	N/A
1.5 x 3	8.7	GXD20S PACK	N/A
1.5 x 4	9.3	GXD20S PACK	E1FW20S PACK-RC
1.5 x 5	9.9	GXD20S PACK	E1FW20S PACK-RC
1.5 x 7	12.4	GXD20 PACK	E1FW20S PACK-RC
1.5 x 12	13.7	GXD25 PACK	E1FW20S PACK-RC
1.5 x 18	16.8	GXD25 PACK	E1FW20 PACK-RC
1.5 x 25	19.8	GXD32 PACK	E1FW20 PACK-RC

Size mm <sup>2</sup> & No. of Cores	Nom. Dia. mm	GXD Gland Ref.	E1FW-RC Gland Ref.
2.5 x 2	4.8	GXD20S PACK	N/A
2.5 x 3	10.1	GXD20S PACK	E1FW20S PACK-RC
2.5 x 4	10.9	GXD20S PACK	E1FW20S PACK-RC
2.5 x 5	11.8	GXD20 PACK	E1FW20S PACK-RC
2.5 x 7	13	GXD20 PACK	E1FW20S PACK-RC
2.5 x 12	17.3	GXD25 PACK	E1FW20 PACK-RC
2.5 x 18	19.8	GXD32 PACK	E1FW20 PACK-RC
4.0 x 3	11.7	GXD20PACK	E1FW20S PACK-RC
4.0 x 4	12.6	GXD20 PACK	E1FW20S PACK-RC
4.0 x 5	13.9	GXD25 PACK	E1FW20S PACK-RC
4.0 x 7	15.7	GXD25 PACK	E1FW20S PACK-RC
6.0 x 3	14.1	GXD25 PACK	E1FW20S PACK-RC
6.0 x 4	14.8	GXD25 PACK	E1FW20S PACK-RC
6.0 x 5	16.9	GXD25 PACK	E1FW20 PACK-RC
6.0 x 7	18.4	GXD25 PACK	E1FW20 PACK-RC
10 x 4	18.2	GXD25 PACK	E1FW20 PACK-RC
10 x 5	19.8	GXD32 PACK	E1FW20 PACK-RC
10 x 7	22.2	GXD32 PACK	E1FW25 PACK-RC
16 x 4	21.8	GXD32 PACK	E1FW25 PACK-RC
16 x 5	23.5	GXD32 PACK	E1FW25 PACK-RC
25 x 4	25.3	GXD32 PACK	E1FW25 PACK-RC
25 x 5	28.9	GXD40 PACK	E1FW32 PACK-RC
35 x 4	29.7	GXD40 PACK	E1FW32 PACK-RC
50 x 4	34.9	GXD50S PACK	N/A

Due to cable diameter variances between manufacturers, we strongly advise the cable diameter is checked where possible, prior to purchasing the products.

See page 58 and 60 for product details

# Cable Gland Sizing Charts



## Cable Gland Sizing Charts

### CY PVC Signal and Control Cables

Size mm <sup>2</sup> & No. of Cores	Nominal Diameter mm	GXD Gland Ref.	E1FW-RC Gland Ref.
0.5 x 3	7.4	GXD20S PACK	N/A
0.5 x 4	7.9	GXD20S PACK	N/A
0.5 x 5	8.6	GXD20S PACK	N/A
0.5 x 7	9.2	GXD20S PACK	E1FW20S PACK-RC
0.5 x 12	11.6	GXD20 PACK	E1FW20S PACK-RC
0.5 x 18	13.4	GXD20 PACK	E1FW20S PACK-RC
0.5 x 25	15.5	GXD25 PACK	E1FW20S PACK-RC
0.75 x 2	7.2	GXD20S PACK	N/A
0.75 x 3	7.7	GXD20S PACK	N/A
0.75 x 4	8.3	GXD20S PACK	N/A
0.75 x 5	8.9	GXD20S PACK	N/A
0.75 x 7	9.7	GXD20S PACK	E1FW20S PACK-RC
0.75 x 12	12.1	GXD20 PACK	E1FW20S PACK-RC
0.75 x 18	15.3	GXD25 PACK	E1FW20S PACK-RC
0.75 x 25	16.8	GXD25 PACK	E1FW20S PACK-RC
1.0 x 2	7.6	GXD20S PACK	N/A
1.0 x 3	8.1	GXD20S PACK	N/A
1.0 x 4	8.6	GXD20S PACK	N/A
1.0 x 5	9.7	GXD20S PACK	E1FW20S PACK-RC
1.0 x 7	10.5	GXD20S PACK	E1FW20S PACK-RC
1.0 x 12	13.4	GXD20 PACK	E1FW20S PACK-RC
1.0 x 18	15.6	GXD25 PACK	E1FW20S PACK-RC
1.0 x 25	18.1	GXD25 PACK	E1FW20S PACK-RC

Size mm <sup>2</sup> & No. of Cores	Nominal Diameter mm	GXD Gland Ref.	E1FW-RC Gland Ref.
1.5 x 2	8.6	GXD20S PACK	N/A
1.5 x 3	9.1	GXD20S PACK	N/A
1.5 x 4	10.1	GXD20S PACK	E1FW20S PACK-RC
1.5 x 5	10.6	GXD20S PACK	E1FW20S PACK-RC
1.5 x 7	11.5	GXD20 PACK	E1FW20S PACK-RC
1.5 x 12	15.1	GXD25 PACK	E1FW20S PACK-RC
1.5 x 18	17.4	GXD25 PACK	E1FW20S PACK-RC
2.5 x 3	10.4	GXD20S PACK	E1FW20S PACK-RC
2.5 x 4	11.3	GXD20 PACK	E1FW20S PACK-RC
2.5 x 5	12.9	GXD20 PACK	E1FW20S PACK-RC
2.5 x 7	13.9	GXD25 PACK	E1FW20S PACK-RC
4.0 x 4	13.5	GXD25 PACK	E1FW20S PACK-RC
4.0 x 5	14.8	GXD25 PACK	E1FW20S PACK-RC
6.0 x 4	15.9	GXD25 PACK	E1FW20S PACK-RC
6.0 x 5	17.4	GXD25 PACK	E1FW20S PACK-RC
10 x 4	19.1	GXD32 PACK	E1FW20S PACK-RC
10 x 5	22.6	GXD32 PACK	E1FW25S PACK-RC
16 x 4	22.3	GXD32 PACK	E1FW25S PACK-RC
25 x 4	32.5	GXD50S PACK	N/A
35 x 4	35.6	GXD50S PACK	N/A
50 x 4	38.7	GXD50S PACK	N/A
70 x 4	43.8	GXD50S PACK	N/A

Due to cable diameter variances between manufacturers, we strongly advise the cable diameter is checked where possible, prior to purchasing the products.

See page 58 and 60 for product details

# Aluminium Cable Glands

## PEX® CW Aluminium Cable Gland Pack



Application: Aluminium indoor and outdoor gland suitable for all types of aluminium wire armoured cable (AWA), providing an environmental seal on the cable outer sheath. The gland also provides mechanical retention and electrical continuity via armour wire termination.

Operating Temperature (standard seals): -20°C to +80°C

Ingress Protection: IP66 EN60529

Approval: BS EN 50262:1999

Material: Aluminium Alloy

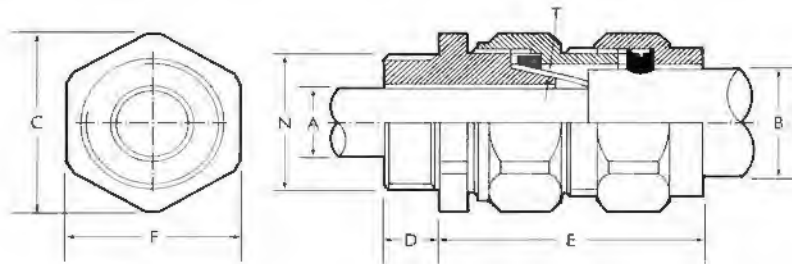

Part No.	Pack Quantity	Entry Thread		Cable Acceptance Details			Hexagonal Details				Assembled Length E
		Diameter N	Length D	Diameter A max	Diameter B min max	Armour wire size T	A/F Gland Body F	A/C Gland Body C	A/F Compression Nut F	A/C Compression Nut C	
PCW20AL - PK	2	20	10	13.8	15.5 - 20.5	0.90/1.25	26.0	28.9	28.0	31.1	40.0
PCW25AL - PK	2	25	10	19.8	20.3 - 27.0	1.25/1.60	34.0	37.9	36.0	40.0	44.0
PCW32AL - PK	2	32	10	26.4	27.0 - 33.5	1.60/2.00	43.0	47.7	45.0	50.0	50.0
PCW40AL - PK	1	40	15	32.4	3.0 - 40.0	1.60/2.00	50.0	55.5	55.0	61.1	52.0
PCW50SAL - PK	1	50	15	38.0	39.8 - 46.3	2.00/2.50	57.0	63.3	60.0	66.6	54.0
PCW50AL - PK	1	50	15	44.0	46.0 - 52.5	2.00/2.50	62.0	68.8	65.0	72.2	54.0
PCW63SAL - PK	1	63	15	49.0	52.0 - 59.5	2.50	70.0	77.7	75.0	83.2	58.0
PCW63AL - PK	1	63	15	55.5	58.4 - 65.3	2.50	75.0	83.2	80.0	88.8	58.0

All dimensions are in mm.



## Polyamide Metric Cable Glands

**Material:** Polyamide 6 (halogen free) Trade name: Ultramid B.

**Protection Class:** IP68 5 bar.

**Temperature Range:** -30°C to +80°C.

**Operation Temperature:** Up to +150°C intermittent.

**Seal:** Neoprene.

**Approvals:** Underwriters Laboratories (UL Approval) - Cert. no: E178501(N).



Canadian Standards (CSA Approval) - Cert. no: 1454383.

VDE Approval DIN EN 50262 (VDE 0619).

### Properties of Plastic Cable Glands:

Gross density DIN 53457: 1.14g/cm<sup>3</sup>

### Chemical Characteristics: Resistant to:

Acids - high concentrate (conditionally resistant).

Acids - low concentrate.

Fuel DIN gasoline/super.

Vegetable oils and fats.

Fuel DIN diesel.

Leys - low and high

Mineral oil.

concentrate.

### Mechanical Values (at 23°C)

Tensile Strength	DIN 53455:	50N/mm <sup>2</sup>
Bending Stress Limit	DIN 53455:	130N/mm <sup>2</sup>
Notch Impact Strength	DIN 53455:	No break

### Electrical Values (at 23°C)

Dielectric Strength	DIN 53455	100 - 150 Kv/m
Surface Resistance	DIN 53455	10 <sup>10</sup> Ohm

Part No.*	Unit Of Supply	TD (mm)	TL (mm)	Wrench (mm)	Clamping Range (mm)	Recom. Cap Tightening Torque (Nm)
CG/LNM12	50	12	8	15	3.0 - 6.5	1.7
CG/LNM16	50	16	10	22	5.0 - 10.0	2.5
CG/LNM20S	50	20	10	24	6.0 - 12.0	2.5
CGLNM20S - PK10	10	20	10	24	6.0 - 12.0	2.5
CG/LNM20	50	20	10	27	10.0 - 14.0	3.3
CGLNM20 - PK10	10	20	10	27	10.0 - 14.0	3.3
CG/LNM20L LT	50	20	15	27	10.0 - 14.0	3.3
CG/LNM25	25	25	10	33	13.0 - 18.0	5.0
CGLNM25 - PK10	10	25	10	33	13.0 - 18.0	5.0
CG/LNM32	EA	32	18	42	18.0 - 25.0	11.0
CG/LNM40	EA	40	18	53	22.0 - 32.0	12.0
CG/LNM50	EA	50	18	60	30.0 - 38.0	12.0
CG/LNM63	EA	63	18	65	34.0 - 44.0	12.0

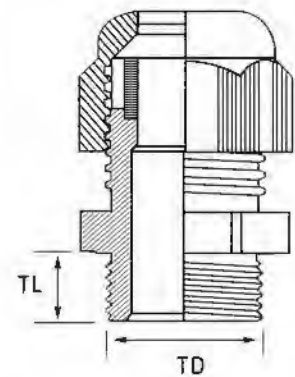

CG/LNM Glands supplied with washer and locknut.

Locknuts available seperately - Prices P.O.A

### \* Specify colour required

Standard colours: black (RAL 9005), dark grey (RAL 7001), light grey (RAL 7035), white (RAL 9003), red (RAL 53025), blue (RAL 5015).

(N.B colours limited on certain sizes - 40mm, 50mm & 63mm only available in black & light grey)

## Cable Glands

### Polyamide PG Cable Glands



Part No.*	Unit Of Supply	TD (mm)	TL (mm)	 (mm)	Clamping Range (mm)	Recom. Cap Tightening Torque (Nm)
CGPG7	Each	13	8	15	3.0 - 6.5	1.7
CGPG9	Each	16	8	19	4.0 - 8.0	2.5
CGPG11	Each	19	8	22	5.0 - 10.0	2.5
CGPG13.5	Each	21	9	2	6.0 - 12.0	2.5
CGPG16	Each	23	10	27	10.0 - 14.0	3.3
CGPG21	Each	29	11	33	13.0 - 18.0	5.0
CGPG29	Each	37	11	42	18.0 - 25.0	5.0
CGPG36	Each	47	13	53	22.0 - 32.0	12.0
CGPG42	Each	54	13	60	30.0 - 38.0	12.0
CGPG48	Each	59	14	65	34.0 - 44.0	12.0

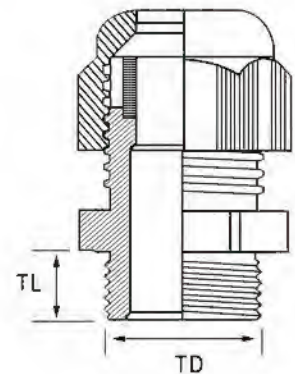

Locknuts supplied separately - Part No. PLNPG (size) - (colour) e.g. PLNPG7-G

**\* Specify colour required**

Standard colours: black (RAL 9005), dark grey (RAL 7001), light grey (RAL 7035), white (RAL 9003), red (RAL 53025), blue (RAL 5015)  
(N.B colours limited on certain sizes)

### Commercial TRS Range

**Material:** Polyamide 6 (halogen free) Trade name: Ultramid B.

**Protection Class:** IP54.

Part No.	Colour	Cable Range (mm)	Part No.	Colour	Cable Range (mm)
CG251B-PK10	Black	7.0 - 10.0	CG252B-PK10	Black	8.0 - 13.0
CG251W-PK10	White	7.0 - 10.0	CG252W-PK10	White	8.0 - 13.0
CG251R-PK10	Red	7.0 - 10.0	CG252R-PK10	Red	8.0 - 13.0

Pack Quantity: 10

Glands supplied with locknuts.

Pack Quantity: 10



# Cable Glands

## Polyamide Metric Cable Glands

### Hazardous Areas



Examination Certificate Number: IMQ 08 ATEX 012 X.

Examination & Test Report Number: 43AI00015-43AI00015.1.

Safety Requirements: EN60079-0:2006 / EN60079-7:2007 .  
EN60079-11:2007 / EN61241-1:2004

Equipment Marking: Increased Safety "e" and Intrinsic Safety "I" x II 2GD  
Ex e II, Ex i, Ex tD A21 (The Cable Glands Ex e II can be used with circuits EX i. These Cable Glands should have a nut painted light blue).

Suitable for use in: ZONE1, ZONE2 for Groups IIA, IIB, IIC.

For: Gas & Dust potential explosive atmospheres

Degree of Protection: IP66-IP68 (EN 60529)

Temperature Classes: +20°C / +80°C

For equivalence PG Threads see table A. Thread tolerance in according ISO 965-1± / -965-3 for dimensions ISO pitch 1,5 and PG DIN 400430. Can be used also threads ANSI ASME B1.20.1 NPT.

Table A

Metric	Standard threads							
		12	16	20	25	32	40	50
Pg	Equivalent threads							
		7	9-11	13,5-16	21	29	36	42

Part No.	M ISO-pitch 1,5	R ∅ Standard Rubber min-max	L	Dimensions mm		
				H min	CH	CH1
CGLNM20SB-EEXE	20	6,0 - 12,0	10	41	24	24
CGLNM20B-EEXE	20	10,0 - 14,0	10	42	27	27
CGLNM25B-EEXE	25	13,0 - 18,0	10	47	33	33
CGLNM32B-EEXE	32	18,0 - 25,0	15	58,5	42	42
CGLNM40B-EEXE	40	22,0 - 32,0	18	68	53	53
CGLNM50B-EEXE	50	30,0 - 38,0	18	69	60	60
CGLNM63B-EEXE	63	34,0 - 44,0	18	71	65	65

Sold in eaches

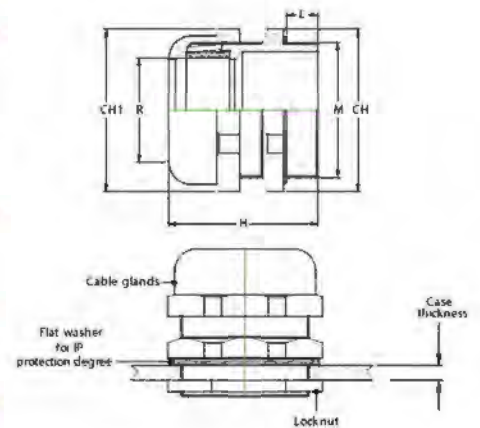

# Hygienic Cable Glands - Standard Type

## Technical Details

- Application areas**
- Manufacturing and packaging of food and pharmaceuticals
  - Clean room technology
  - Biotechnology
  - Chemical industry

- Benefits**
- Smooth finish prevents harmful micro organisms to adhere to the surface
  - No threads are exposed
  - Cleaning of cable glands is easier, faster and less expensive compared to traditional stainless steel cable glands
  - Reliable strain relief due to strain relief element separated from grommet
  - Suitable for high pressure steam cleaning

<b>Item</b>	<b>Material</b>
Body & Cap	Stainless Steel 1.4404 (AISI 316L) other stainless steel grades available on request
Gasket	TPE according to FDA guideline 21 CFR 177-2600
Clamping Insert	POM
Lock Nut	Stainless Steel 1.4305 (AISI 303)
<b>Protection Class</b>	IP68 (5 bar, 30 min) according to EN 60529 IP69K according to DIN 40050-9

## Operating Temperature

Permanent	-20°C up to +100°C
Intermittent	-40°C up to +150°C

**Attachment Thread** Metric according to EN 60423  
Pg and NPT available on request



## Tightening Tool

Part No.	Gland Type	SW B	SW C	H
<b>HCG-TT12</b>	M12	5	7	5
<b>HCG-TT16</b>	M16	6	10	5
<b>HCG-TT20</b>	M20	8	13	8
<b>HCG-TT25</b>	M25	10	17	8

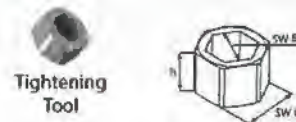

Scan to view demo

## Gland

### Cable Gland Dimensions

Part No.	Thread Type	Cable Clamping Range mm	Cable Gland Dimensions							Rec Cap Tightening Torque Nm	
			SW A mm	SW C mm	TD mm	D1 mm	D2 mm	H mm	TL mm		
<b>HCG12</b>	M12 x 1.5	3.0 - 6.5	14.0	7.0	12.0	15.6	6.8	21.5	6.0	2.5	
<b>HCG16</b>	M16 x 1.5	5.0 - 10.0	18.0	10.0	16.0	20.2	10.3	23.0	7.0	4.0	
<b>HCG20</b>	M20 x 1.5	6.0 - 12.0	22.0	13.0	20.0	24.1	12.3	27.0	10.0	5.0	
<b>HCG25</b>	M25 x 1.5	12.0 - 17.0	28.0	17.0	25.0	30.1	17.3	30.0	14.0	6.0	
Locknut	Thread Type	SW L mm	e mm		Rec Locknut Tightening Torque Nm						
			M12 x 1.5	15	2.8	6.0					
			M16 x 1.5	19	3.0	9.0					
M20 x 1.5	24	3.5	12.0								
M25 x 1.5	30	4.0	14.0								

Sold in eases



TEL: (44) 01453 844333 | FAX: (44) 01453 842224 | E-MAIL: sales@swaonline.co.uk

# Hygienic Cable Glands - EMC Type

## Technical Details

**Application areas** ■ Manufacturing and packaging of food and pharmaceuticals

- Clean room technology
- Biotechnology
- Chemical industry

## Benefits

- Smooth finish prevents harmful micro organisms to adhere to the surface
- No threads are exposed
- Cleaning of cable glands is easier, faster and less expensive compared to traditional stainless steel cable glands
- Reliable strain relief due to strain relief element separated from grommet
- Suitable for high pressure steam cleaning

## Item

Body & Cap

## Material

Stainless Steel 1.4404 (AISI 316L)  
other stainless steel grades  
available on request

Gasket

TPE according to FDA guideline  
21 CFR 177-2600

Clamping Insert

POM

Lock Nut

Stainless Steel 1.4305 (AISI 303)

## Protection Class

IP68 (5 bar, 30 min) according to EN 60529  
IP69K according to DIN 40050-9

## Operating Temperature

Permanent -20°C up to +100°C

Intermittent -40°C up to +150°C

## Attachment Thread

Metric according to EN 60423  
Pg and NPT available on request

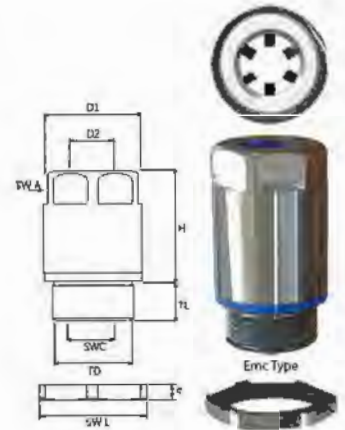

## Tightening Tool

Part No.	Gland Type	SW B	SW C	H
HCG-TT12	M12	5	7	5
HCG-TT16	M16	6	10	5
HCG-TT20	M20	8	13	8
HCG-TT25	M25	10	17	8

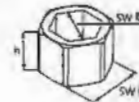

Scan to  
view demo

## EMC Type (Gland and Locknut)

### Cable Gland Dimensions

Part No.	Thread Type	Cable Clamping Range mm	SW A mm	SW C mm	TD mm	D1 mm	D2 mm	H mm	TL mm	Rec Cap Tightening
										Torque Nm
HCG16-EMC	M16 x 1.5	5.0-10.0	18.0	10.0	16.0	20.2	10.3	28.5	7.0	4.0
HCG20-EMC	M20 x 1.5	6.0-12.0	22.0	13.0	20.0	24.1	12.3	33.0	10.0	5.0
HCG25-EMC	M25 x 1.5	12.0-17.0	28.0	17.0	25.0	30.1	17.3	38.0	14.0	6.0
Locknut	Thread Type	SW L mm		e mm		Rec Locknut Tightening Torque Nm				
	M16 x 1.5	19		3.0		9.0				
	M20 x 1.5	24		3.5		12.0				
	M25 x 1.5	30		4.0		14.0				

Sold in eaches



# Cable Glands

## EMC Glands for Electromagnetical Purposes



EMC

EMC Grip Range

**Applications:**

- Suitable for the shielding of cable for electromagnetical purposes.
- Cable gland with neoprene sealing-ring and polyamide traction relief clamping insert.
- Supplied with lock-nut and neoprene O-ring on entry thread.

Approval: BS EN 50262:1999

Ingress Protection: IP68 EN60529

Temperature Rating: -20°C to +100°C

Pressure Rating: 5 bar

Finish: Bright nickel-plated

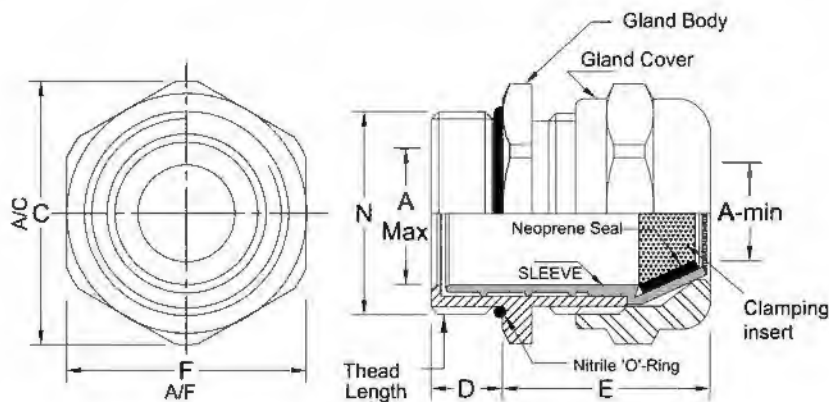

### EMC Range

Part No.	Entry Thread		Cable Acceptance Details		Hexagonal Details		Assembled Length
	Thread	Length	Minimum	Maximum	A/F	A/C	
	N	D	A	A	F	C	E
<b>EMC16NP</b>	M16 x 1.5	10.0	5.5	9.0	18.0	20.0	17.0
<b>EMC20NP</b>	M20 x 1.5	10.0	8.5	12.5	22.0	24.4	18.0
<b>EMC25NP</b>	M25 x 1.5	10.0	12.0	16.5	27.0	30.0	20.0
<b>EMC32NP</b>	M32 x 1.5	13.0	16.0	21.0	34.0	37.7	23.0
<b>EMC40NP</b>	M40 x 1.5	13.0	19.5	27.0	43.0	47.7	29.0
<b>EMC50NP</b>	M50 x 1.5	14.0	25.0	34.0	55.0	61.0	34.0
<b>EMC63NP</b>	M63 x 1.5	14.0	32.0	42.0	68.0	75.5	35.0

All dimensions are in mm

EMC LP Range on following page

## Cable Glands

### EMC Glands for Electromagnetical Purposes



EMC NP-LP Range

#### Applications:

- Suitable for the shielding of cable for electromagnetical purposes.
- Cable gland with neoprene sealing-ring and polyamide traction relief clamping insert.
- Supplied with lock-nut and neoprene O-ring on entry thread.

Ingress Protection: IP68 EN60529

Temperature Rating: -40°C to +100°C

Pressure Rating: 5 bar

Finish: Bright nickel-plated

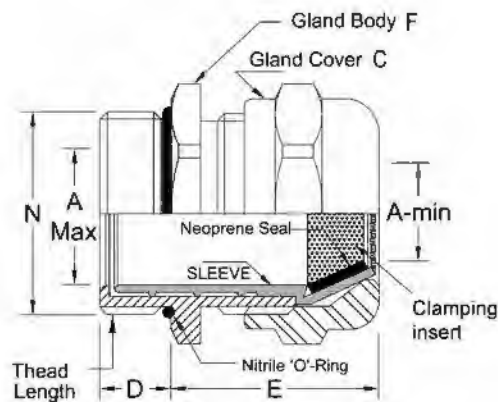

#### EMC LP Range

Part No.	Entry Thread		Cable Acceptance Details		Hexagonal Details		Assembled Length
	Thread	Length	Minimum	Maximum	Body	Gland Cover	
	N	D	A	A	F	C	E
<b>EMC16NP-LP</b>	M16 x 1.5	8.0	4.0	8.0	18.0	17.0	23.0
<b>EMC20NP-LP</b>	M20 x 1.5	8.0	6.0	12.0	22.0	22.0	24.3
<b>EMC25NP-LP</b>	M25 x 1.5	8.0	10.0	14.0	27.0	24.0	27.6
<b>EMC32NP-LP</b>	M32 x 1.5	9.0	13.0	18.0	34.0	30.0	31.2
<b>EMC40NP-LP</b>	M40 x 1.5	9.0	18.0	25.0	43.0	40.0	38.5
<b>EMC50NP-LP</b>	M50 x 1.5	9.0	22.0	32.0	55.0	50.0	47.3
<b>EMC63NP-LP</b>	M63 x 1.5	14.0	34.0	44.0	68.0	64.0	50.3

All dimensions are in mm.

Sold in Eaches

# CABLE FIXINGS



**Fix-A-Box™**.....30-31



**Nylon Cable Ties**.....82-85



**Special Purpose Cable Ties**.....86



**Nylon Cable Tie Accessories**.....87-88



**Stainless Steel Cable Ties**.....89-90



**Stainless Steel Banding Tape & Buckles**.....90



**Fire Safety Clips**.....90



**Cable Protection Accessories**.....91



**Cable Cleats**.....92-93



**Aluminium Cable Cleats**.....94-96



**Fixing Band**.....97

CABLE FIXINGS

# Nylon Cable Ties



**RoHS**  
Compliant



## Standard Cable Ties

Suitable for a variety of applications, such as cable binding or harnessing

- Manufactured from UL approved virgin nylon 6/6
- General operating temperature: -40°C to 85°C
- Flammability rating: UL94V-2 (self-extinguishing within 30 seconds)
- UV resistant for outdoor use (black ties only)
- Black ties are halogen free
- RoHS compliant

### Black and Natural Ties

Part No.	Size (mm)	Colour	Min. Tensile Strength (kg)
CT100-2.5N	100 x 2.5	Natural	8
CT100-2.5B	100 x 2.5	Black	8
CT160-2.5N	160 x 2.5	Natural	8
CT160-2.5B	160 x 2.5	Black	8
CT200-2.5N	200 x 2.5	Natural	8
CT200-2.5B	200 x 2.5	Black	8

Pack Quantity: 100

Part No.	Size (mm)	Colour	Min. Tensile Strength (kg)
CT100-2.5N/K	100 x 2.5	Natural	8
CT100-2.5B/K	100 x 2.5	Black	8

Pack Quantity: 1000

Part No.	Size (mm)	Colour	Min. Tensile Strength (kg)
CT140-3.6N	140 x 3.6	Natural	18
CT140-3.6B	140 x 3.6	Black	18
CT200-3.6N	200 x 3.6	Natural	18
CT200-3.6B	200 x 3.6	Black	18
CT300-3.6N	300 x 3.6	Natural	18
CT300-3.6B	300 x 3.6	Black	18

Pack Quantity: 100

Part No.	Size (mm)	Colour	Min. Tensile Strength (kg)
CT120-4.8N	120 x 4.8	Natural	22
CT120-4.8B	120 x 4.8	Black	22
CT160-4.8N	160 x 4.8	Natural	22
CT160-4.8B	160 x 4.8	Black	22
CT200-4.8N	200 x 4.8	Natural	22
CT200-4.8B	200 x 4.8	Black	22
CT250-4.8N	250 x 4.8	Natural	22
CT250-4.8B	250 x 4.8	Black	22
CT300-4.8N	300 x 4.8	Natural	22
CT300-4.8B	300 x 4.8	Black	22
CT370-4.8N	370 x 4.8	Natural	22
CT370-4.8B	370 x 4.8	Black	22
CT430-4.8N	430 x 4.8	Natural	22
CT430-4.8B	430 x 4.8	Black	22

Pack Quantity: 100

### Colour Cable Ties

Part No.*	Size (mm)	Min. Tensile Strength (kg)
CT100-2.5	100 x 2.5	8
CT160-2.5	160 x 2.5	8
CT200-2.5	200 x 2.5	8
CT200-4.8	200 x 4.8	22
CT300-4.8	300 x 4.8	22

Pack Quantity: 100

\*Please specify colour required - Red (red), Blue (blu), Yellow (yel), Green (gre), Orange (ora).  
CT300-4.8 also available in silver (svr).

# Nylon Cable Ties



## Standard Cable Ties

### Black and Natural Ties

Part No.	Size (mm)	Colour	Min. Tensile Strength (kg)
CT240-7.8N	240 x 7.8	Natural	54
CT240-7.8B	240 x 7.8	Black	54
CT300-7.8N	300 x 7.8	Natural	54
CT300-7.8B	300 x 7.8	Black	54
CT370-7.8N	370 x 7.8	Natural	54
CT370-7.8B	370 x 7.8	Black	54

Pack Quantity: 100

Part No.	Size (mm)	Colour	Min. Tensile Strength (kg)
CT450-8.0N	450 x 7.8	Natural	54
CT450-8.0B	450 x 7.8	Black	54
CT540-8.0N	540 x 7.8	Natural	54
CT540-8.0B	540 x 7.8	Black	54
CT750-8.0N	750 x 7.8	Natural	54
CT750-8.0B	750 x 7.8	Black	54

Pack Quantity: 100

For coloured cable ties please see previous page

Part No.	Size (mm)	Colour	Min. Tensile Strength (kg)
CT530-9.0N	530 x 9	Natural	79
CT530-9.0B	530 x 9	Black	79
CT780-9.0N	780 x 9	Natural	79
CT780-9.0B	780 x 9	Black	79

Pack Quantity: 100

Part No.	Size (mm)	Colour	Min. Tensile Strength (kg)
CT500-12.6N	500 x 12.6	Natural	114
CT500-12.6B	500 x 12.6	Black	114
CT1000-12.6N	1000 x 12.6	Natural	114
CT1000-12.6B	1000 x 12.6	Black	114

Pack Quantity: 100

### Cable Tie Tensioning Tool - CTG2248

Moulded cable tie tensioning tool complete with cut off facility for nylon ties 2.2mm - 4.8mm width.



### Cable Tie Tensioning Tool - CTG2248MET

Metal cable tie tensioning tool with cut off facility for nylon ties 2.2mm - 4.8mm width.

### Cable Tie Tensioning Tool - CTG3690

Metal cable tie tensioning tool with cut off facility for nylon cable ties 3.6mm - 9.0mm width.



# Nylon Cable Ties

## Push Mounting Cable Ties

Part No.	Length (mm)	Width (mm)	Ø Hole (mm)	Panel Thickness (mm)	Maximum Bundle Dia. (mm)	Minimum Tensile Strength (kg)
CT200-4.8B/PM	200	4.8	6.3	3.6	50	22
CT200-4.8N/PM	200	4.8	6.3	3.6	50	22

**Material:** Nylon 6/6. **Colour:** Natural (NPM) and Black (BPM)  
 Self - extinguishing UL 94 Flammability Class V2.  
 Pack Quantity: 100



## Cable Ties With Mounting Hole

Part No.	Length (mm)	Width (mm)	Maximum Bundle Dia. (mm)	Minimum Tensile Strength (kg)	Screw Hole Size (mm)
CT150-3.6N/MH	150	3.6	32	13	4.5
CT200-4.8N/MH	200	4.8	47	22	4.5
CT200-4.8B/MH	200	4.8	47	22	4.5

**Material:** Nylon 6/6. **Colour:** Natural (NMH) and Black (BMH)  
 Self - extinguishing UL 94 Flammability Class V2.  
 Pack Quantity: 100



## Cable Ties For Identification

Part No.	Length (mm)	Width (mm)	Tab size (mm)	Maximum Bundle Dia. (mm)	Minimum Tensile Strength (kg)
CT100-2.5N/M	100	2.5	25 x 20	20	8
CT200-2.5N/M	200	2.5	28 x 13	20	8
CT200-4.8N/M	200	4.8	28 x 13	48	22

**Material:** Nylon 6/6. **Colour:** Natural  
 Self - extinguishing UL 94 Flammability Class V2.  
 Pack Quantity: 100



4.8mm width



2.5mm width

# Nylon Cable Ties

## Releasable Cable Ties

These ties, which are easily assembled by hand or with pliers, remain securely locked until intentionally released by operating the finger catch.

Suitable for temporary fastening purposes.

Part No.	Length (mm)	Width (mm)	Maximum Bundle Dia. (mm)	Min. Tensile Strength (Kg)
CT200-4.8B/RE	200	4.8	50	22
CT250-7.8B/RE	250	7.8	65	22
CT300-4.8B/RE	300	4.8	80	22
CT370-4.8B/RE	370	4.8	102	22

**Material:** Nylon 6/6. **Colour:** Black  
Self - extinguishing UL 94 Flammability Class V2.  
Pack Quantity: 100



Part No.	Length (mm)	Width (mm)	Maximum Bundle Dia. (mm)	Min. Tensile Strength (Kg)
CT250-7.8RED/RE	250	7.8	65	22

**Material:** Nylon 6/6. **Colour:** Red  
Self - extinguishing UL 94 Flammability Class V2.  
Pack Quantity: 100



## Special Application Cable Ties

### Polypropylene Cable Ties

- For chemical resistance in indoor or for outdoor/weather resistant applications that are unsuitable for standard nylon cable ties
- These ties can be used in areas where hydrochloric acid, salts and bases are present
- One piece construction for consistent performance and reliability
- Curved tip is easy to pick up from flat surfaces and allows faster initial threading to speed installation
- Maximum continuous operating temperature: 115°C
- RoHS compliant
- CE compliant

**Outdoor Applications:** Material Flammability Rating: UL94HB **Colour:** Black

**Indoor Applications:** Material Flammability Rating: Not recognised **Colour:** Green

Outdoor	Part No.	Indoor	Length (mm)	Width (mm)	Maximum Bundle Dia. (mm)	Min. Tensile Strength (Kg)
CT188-4.8B-PP	CT188-4.8G-PP		188	4.8	48	13
CT292-4.8B-PP	CT292-4.8G-PP		292	4.8	76	13
CT368-4.8B-PP	CT368-4.8G-PP		368	4.8	102	13
CT368-7.6B-PP	CT368-7.6G-PP		368	7.6	102	22

Other sizes available on request – subject to minimum order quantities

Pack Quantity: 100



### Metal Content Tie

The metal content tie is a cable tie specifically designed for use in the food, pharmaceutical and chemical processing industries. A unique manufacturing process, involving the inclusion of metallic particles, enables the tie to be detected more readily than standard nylon ties.

- Nylon tie incorporating a metallic compound throughout the length of the tie
- Can be used as part of HACCP process
- Blue in colour to assist in detection (RAL 5007)
- Greatly reduces the risk of contamination

Part No.	Length (mm)	Width (mm)	Maximum Bundle Dia. (mm)	Ave Tensile Strength (Kg)	Ave Tensile Strength (N)
CT140-3.6MC	140	3.6	36	20	200
CT200-4.8MC	200	4.8	51	28	280
CT280-4.8MC	280	4.8	76	28	280
CT380-4.8MC	380	4.8	110	28	280

Pack Quantity: 100

SWA cannot guarantee that our products will be detectable by your metal detectors. Therefore, we cannot take responsibility for any non-detection of our products or their parts. Detectability of our products depends on metal detector settings, and type of food products produced (product composition, size, humidity etc). In order to make sure that our detectable ties will be detected we strongly recommend that you test them on your detectors before use.

**Material:** Detectable ties of polyamide 6.6 **Flame resistance** in accordance with UL94V-HB (not self-extinguishing)  
**Temperature range:** -40°C to +65°C **Water Absorption:** Can absorb up to 8% when immersed.

**Solution Resistance:** Solvents, oils, lubricants petroleum derivatives and Alkalis when used at low temperatures in low concentrates and for short periods of time.

Acids, Phenols and chlorinated solvents - No



CE

RoHS Compliant



# Nylon Cable Tie Accessories

## Self Adhesive Mounts - Two Way

Part No.	Size (mm)	To accept Tie width	Colour
<b>SAM20N-2</b>	19 x 19	3.6mm	Natural
<b>SAM20B-2</b>	19 x 19	3.6mm	Black
<b>SAM28N-2</b>	28 x 28	4.8mm	Natural
<b>SAM28B-2</b>	28 x 28	4.8mm	Black



**Material:** Nylon 6/6

SAM28 supplied with M6 centre screw fixing hole.

For best results mountings should only be applied to clean, dry, smooth surfaces, free from dust, oils, grease or solvents.

Pack Quantity: 100

## Wall Plug Bases

Part No.	Dimensions (mm)				Drill Hole Size (mm)
	A	B	C	D	
CTFB6	6.8	37	6.0	9.2	6
CTFB9	10	37	6.5	9.2	8
CTFB9RH	10	37	13	9.2	8

CTFB6 or CTFB9

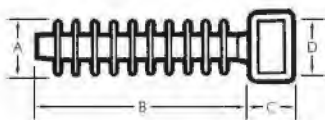

CTFB6 or CTFB9

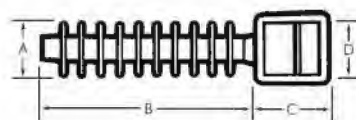

CTFB9RH

CTFB9RH

**Material:** Nylon 6/6.

They are used with cable ties up to 9mm wide. Designed in 2 different types with differing distances from the wall. The wall plug bases avoid friction of the cable on the wall protecting the insulation.

Pack Quantity: 100

# Nylon Cable Tie Accessories

## Cable Tie Supports

Part No.	Max Cable Tie Width (mm)	Ø Screw Hole (mm)	Maximum Support Width (mm)	Support Height (mm)
<b>CTS9B</b>	9.5	5	14	18

Black only.

Screwed support. For cable ties up to 9mm width. Fixing is suitable for either a countersunk or flat head screw. For wall plug max 8mm

Pack Quantity: 100

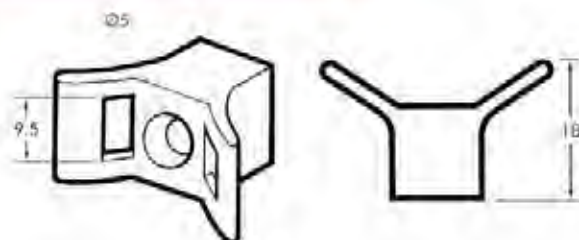

## Cable Tie Eyelets

Part No.		Max Cable Tie Width (mm)	Dimensions mm				
Natural	Black		A	B	C	F	H
<b>EL4.8N</b>	<b>EL4.8B</b>	4.8	10	20	4.3	5	6

Material: Nylon 6/6.

Mounted with standard screws or rivets. Particularly useful when space is limited.

Pack Quantity: 100

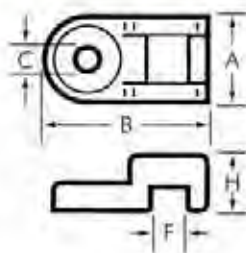

## Cable Tie Cradles

Part No.		Max Cable Tie Width (mm)	Dimensions mm				
Natural	Black		A	B	C	F	H
<b>CRAD48N</b>	<b>CRAD48B</b>	5.0	9.5	15	3.5	5	7
<b>CRAD78N</b>	<b>CRAD78B</b>	9.0	15	25	5	9	11

Material: Nylon 6/6.

They provide extra support for large bundles and many components. They are especially useful in small areas.

Pack Quantity: 100

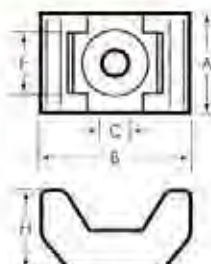

# Stainless Steel Cable Ties

## Stainless Steel Roller-Ball Lock Tie

- Stainless steel 316L to BS EN1008:1995 with a unique locking ball mechanism that allows the tie to be quickly and easily installed
- Ideal for use in environmentally harsh conditions where subjected to various chemicals, acids, salts, and high temperatures
- Black epoxy coated LSZH (low smoke, zero halogen) ties also available providing additional insulation and protection to the bundle materials



BS5839 PT1

	Uncoated	Coated
Min. Operating Temp:	-40°C	-40°C
Max. Operating Temp:	+550°C	+180°C

Part No.	Length (mm)	Width (mm)	Bundle dia. (mm)	Min. loop Tensile Strength (Kg)	
					Plain
SSTRB201-4.6	SSTRB201-4.6EC	201	4.6	50	45
SSTRB266-4.6	SSTRB266-4.6EC	266	4.6	72	45
SSTRB300-4.6	SSTRB300-4.6EC	300	4.6	81	45
SSTRB362-4.6	SSTRB362-4.6EC	362	4.6	102	45
SSTRB362-7.9	SSTRB362-7.9EC	362	7.9	102	Plain 113, Coated 79
SSTRB521-7.9	SSTRB521-7.9EC	521	7.9	152	Plain 113, Coated 79
SSTRB679-7.9		679	7.9	203	Plain 113
SSTRB838-7.9		838	7.9	254	Plain 113
SSTRB1067-7.9		1067	7.9	320	Plain 113

Pack Quantity 100, except 838 & 1067 – Pk50

Cable tie tensioning gun available: SSTCT1  
See Page 175.



## Plain Stainless Steel Ties

- Corrosion resistant
- AISI 304 stainless steel (plain ties)
- The unique buckle design provides quick, easy application which can easily be unfastened for re-using
- 6.3mm and 9.5mm widths available
- Minimum operating continuous temperature: -80°C (-112°F)
- Maximum operating continuous temperature: 538°C (1000°F)

Part No.	Length (mm)	Width (mm)	Bundle dia. (mm)
SSTNR150-6	152 (6")	6.3 (1/4")	25 (1.5")
SSTNR225-6	225 (9")	6.3 (1/4")	63 (2.5")
SSTNR300-6	300 (12")	6.3 (1/4")	86 (3.4")
SSTNR450-6	450 (18")	6.3 (1/4")	137 (5.4")
SSTNR610-6	610 (24")	6.3 (1/4")	185 (7.3")

Pack Quantity: 100



# Stainless Steel Cable Ties

## Nylon Coated Stainless Steel Ties

- AISI 304 grade with Nylon 11 coating, which has excellent chemical and weathering resistance
- The unique buckle design provides quick, easy application which can easily be unfastened for re-using
- Corrosion resistant
- 6.3mm and 9.5mm widths available
- Minimum operating continuous temperature: -80°C (-112°F)
- Maximum operating continuous temperature: 538°C (1000°F)

Part No.	Length (mm)	Width (mm)	Bundle dia. (mm)
SSTNR229-6NC	229 (9")	6.3 (1/4")	63 (2.5")
SSTNR305-6NC	305 (12")	6.3 (1/4")	86 (3.4")
SSTNR457-6NC	457 (18")	6.3 (1/4")	137 (5.4")
SSTNR457-9NC	457 (18")	9.5 (3/8")	137 (5.4")



Pack Quantity: 100

## Fire Safety Clips for Trunking

- The safe way to fix fire resistant cables inside cable trunking
- Tested and Approved to BS 5839-1 requirement
- Suitable for 25 x 16mm trunking
- Fold-over tabs for quick and easy fixing

Part No.	Description	Performance	Pack Qty
FSC2	Zinc plated steel	Melt point over 1000°C	50



## Stainless Steel Banding Tape & Buckles

### Stainless Steel Banding Tape

- Type AISI304 stainless steel
- Excellent corrosion resistance
- Ideal for fixing insulation, bundling and securing of cables and pipes

Part No.	Length (m)	Width (mm)	Thickness (mm)	Weight (kg)
SSBT9	30.5	9.5	0.6	1.4
SSBT12	30.5	12.7	0.7	2.1
SSBT16	30.5	16.0	0.7	2.7
SSBT19	30.5	19.0	0.7	3.2



### Stainless Steel Buckles

Part No.	Box Quantity	To suit band
SSB9	100	SSBT9 (9.5mm width)
SSB12	100	SSBT12 (12.7mm width)
SSB16	100	SSBT16 (16mm width)
SSB19	100	SSBT19 (19mm width)



### Application Tools

SSBTT19 – Mechanical tensioning tool suitable for stainless steel strapping band up to 19mm width.



# Cable Protection Accessories

## Grommets

### Open & Closed Type - GRO/GRC Range



- Low cost protection for wires and cables passing through metal panels
- Quick and easy to install
- Closed hole versions available for later insertion of cables or wires
- Material: PVC

- Colour: Black
- Hardness: 48 to 55 Shore A
- RoHS Compliant

### Open/Closed Grommets

Part No.		Dimensions mm				
Open	Closed	A	B	C	D	E
GRO20	GRC20	23.7	20.1	15.5	6.1	1.7
GRO25	GRC25	29.9	25.1	18.9	7.2	1.5
GRO32		38.2	31.7	23.5	8.3	1.6
	GRC32	38.0	31.8	23.5	7.0	1.6

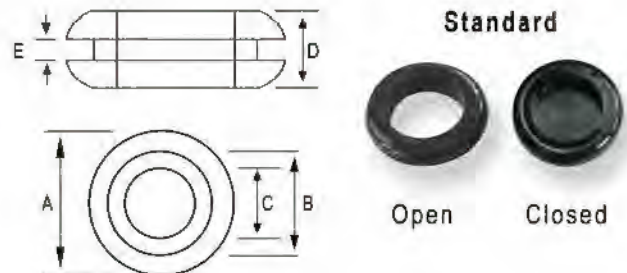

Pack Quantity: 100

### Open/Closed 'Easy-Fit' Grommets

Part No.		Dimensions mm					
Open	Closed	A	B	C	D	E	F
GRO20-EF	GRC20-EF	23.9	19.6	15.5	2.1	2.0	3.9
GRO25-EF	GRC25-EF	30.0	26.0	20.8	2.4	2.4	3.8

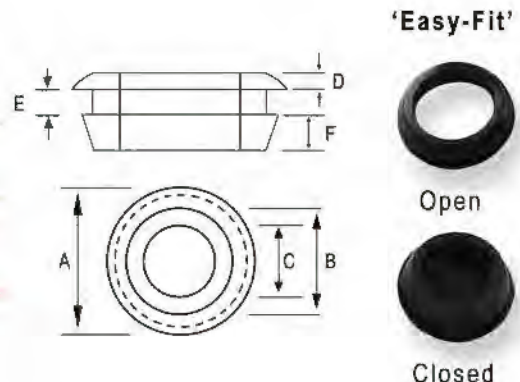

Pack Quantity: 100

Selekt-A-Box™ version pack also available - see page 29.

## Grommet Strip

Flexible polyethylene strip ideal for protecting sharp edges of panels, cut-outs or holes - ensuring a good grip of panels with a thickness up to 5.5mm without the need of adhesives or special tools.

- Operating temperature: -60°C to +55°C
- Colour: Natural

Part No.	To suit plate thickness (mm)	Part No.	To suit plate thickness (mm)
GS1012-25	1.0 - 1.2	GS2024-25	2.0 - 2.4
GS1216-25	1.2 - 1.6	GS2432-25	2.4 - 3.2
GS1620-25	1.6 - 2.0	GS4555-25	4.5 - 5.5

Pack Quantity: 25 metres





## One Piece Single Fixing Cable Cleats

A comprehensive range of single fixing cable cleats to provide a simple, but strong means of securing cables. Suitable for use with cables or pipes up to 50.8mm in overall diameter. The range is augmented by the two part two hole fixing cleats which cover from 50mm to 85mm overall diameter.

### Features

- Manufactured in high strength polypropylene not polyethylene
- High impact resistance
- Unaffected by corrosive environments
- Higher mechanical strength than polyethylene
- High level of resistance to ultra violet light
- Stability down to -35°C and up to 105°C constant

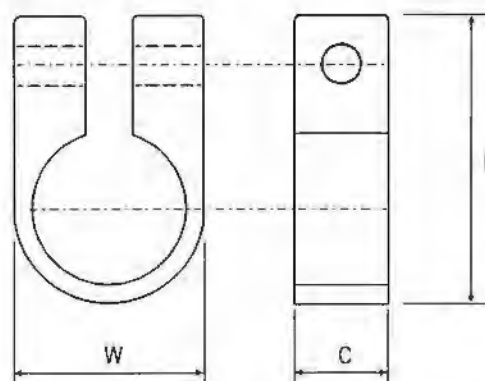

Part No.	Cable Diameters mm		Dimensions mm			Clearance Bolt Holes	Pack Quantity
	Min	Max	W	C	L		
<b>C3-100</b>	5.0	7.6	12.5	15.0	26.5	6	100
<b>C4-100</b>	7.7	10.0	15.0	15.0	27.0	6	100
<b>C5-100</b>	10.1	12.7	18.0	14.2	27.7	6	100
<b>C6-100</b>	12.6	15.2	20.0	15.0	31.0	6	100
<b>C7-100</b>	15.1	17.8	23.0	15.0	33.7	6	100
<b>C8-100</b>	17.7	20.3	25.0	16.0	38.0	6	100
<b>C9-100</b>	20.2	22.8	28.5	16.0	41.0	6	100
<b>C10-100</b>	22.7	25.4	30.0	16.0	44.0	6	100
<b>C11-50</b>	25.3	27.7	34.2	20.0	49.5	10	50
<b>C12-50</b>	27.6	30.5	36.0	20.0	52.0	10	50
<b>C14-50</b>	30.4	35.5	42.0	21.5	59.0	10	50
<b>C16-50</b>	35.4	40.6	47.0	21.5	64.0	10	50
<b>C18-50</b>	40.5	45.7	51.0	21.5	68.5	10	50
<b>C20-50</b>	45.6	50.8	56.5	21.5	73.0	10	50

Low Smoke Halogen Free & Fire Retardant Cleats (LSF) range available on request.

## Cable Cleats



### TC Two Part Two Hole Fixing Cable Cleats

The TC range is manufactured in polypropylene, a plastic which has high electrical resistance, excellent tensile strength and stability at high and low temperatures. An ideal clamp where there is a highly corrosive atmosphere. Manufactured in black to minimise possibility of U.V damage.

The two part range for cables 50mm - 85mm diameter is intended to augment our range of single fixing cleats which accommodate cable from 5.0mm in overall diameter to 50.8mm in overall diameter.

#### Features

- Manufactured in high strength polypropylene not polyethylene
- High impact resistance
- Unaffected by corrosive environments
- Higher mechanical strength than polyethylene
- High level of resistance to ultra violet light
- Stability down to -35°C and up to 105°C constant
- Supplied - one cleat per pack

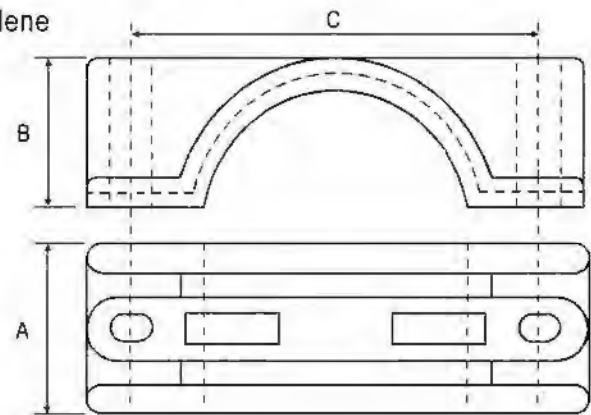

Part No.	Cable Diameters mm		Dimensions mm			Clearance Bolt Holes
	Min	Max	A	B	C	
<b>TC8</b>	41.0	48.0	59.0	31.0	75.0	2 x 10mm
<b>TC9</b>	48.0	57.0	60.0	32.0	76.2	2 x 10mm
<b>TC10</b>	57.0	64.0	60.0	35.0	76.2	2 x 10mm
<b>TC11</b>	64.0	70.0	62.5	40.0	114.3	2 x 10mm
<b>TC12</b>	70.0	76.0	62.5	44.0	114.3	2 x 10mm
<b>TC14</b>	76.0	85.0	63.5	46.5	114.3	2 x 10mm

LSF: Low Smoke Halogen Free & Fire Retardent Cleats available on request.  
Larger sizes available.

# Cable Cleats



## Aluminium Claw Cleats

### Description

- Suitable for use with cables from 10 to 51mm in diameter
- Available in 9 sizes
- Can be used for all types of cable routes
- Plain finish - for indoor dry normal industrial use or outdoor unpolluted areas
- Operating temperature: -60°C to +100°C
- Two piece single fixing design
- Can be stacked to a maximum of 3 on one fixing

CABLE AND CLEAT SELECTION			CLEAT DETAILS						
Part No.	Cable Diameter A (mm)		Dimensions (mm)				Approx. Weight (g)	SWL (FOS 3) Kg	Stud Size
	Min	Max	B	C	D	E			
ACC10-13	10	13	21	38	46	16	60	150	M10
ACC13-16	13	16	36	44	43	16	50	148	M10
ACC16-19	16	19	38	48	43	18	60	121	M10
ACC19-22	19	22	38	50	43	18	70	112	M10
ACC22-25	22	25	40	53	43	20	80	95	M10
ACC25-32	25	32	44	59	43	24	90	85	M10
ACC32-38	32	38	50	65	43	27	110	83	M10
ACC38-44	38	44	56	71	43	30	120	60	M10
ACC44-51	44	51	63	78	43	33.5	150	62	M10

SWL: Safe Working Load FOS 3: Values include a safety factor of 3

Sold in eashes

### Method of Fixing

In all applications the cleats should be mounted on suitable fixings.

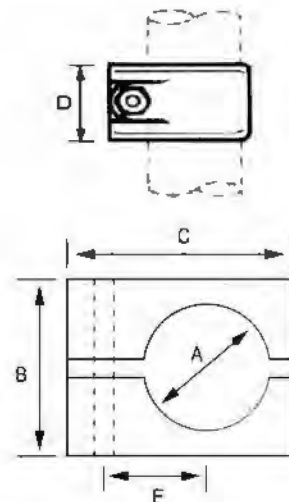





## Aluminium Two Bolt Cleats

### Description

- Suitable for use with cables from 51mm to 114mm in diameter
- Available in 10 sizes
- Can be used for all types of cable routes
- Plain finish - for indoor dry normal industrial use or outdoor unpolluted areas
- Operating temperature: -60°C to +100°C
- Two piece two fixing design
- Can be double stacked on common fixings

CABLE AND CLEAT SELECTION			CLEAT DETAILS						
Part No.	Cable Diameter A (mm)		Dimensions (mm)				Approx. Weight (g)	SWL (FOS 3) (Kg)	Stud Size
	Min	Max	B	C	D	E			
ATC51-57	51	57	68	96	49	38	230	408	M10
ATC57-64	57	64	75	96	49	38	240	665	M10
ATC64-70	64	70	84	134	64	57	410	622	M10
ATC70-76	70	76	90	134	64	57	400	617	M10
ATC76-83	76	83	96	142	64	57	410	600	M12
ATC83-89	83	89	102	142	64	57	490	600	M12
ATC89-95	89	95	114	154	76	63	650	600	M12
ATC95-101	95	101	120	154	76	63	650	600	M12
ATC101-108	101	108	134	169	76	70	900	600	M12
ATC108-114	108	114	140	169	76	70	900	600	M12

SWL: Safe Working Load FOS 3: Values include a safety factor of 3

Sold in eaches

### Method of Fixing

In all applications the cleats should be mounted on suitable fixings.

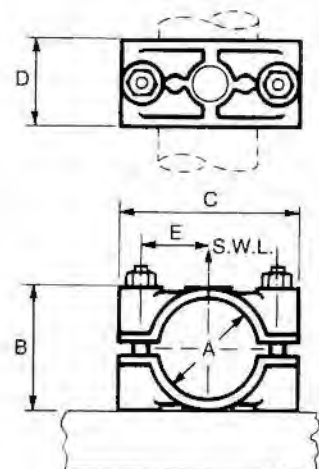

## Trefoil Cleats - Aluminium Single Bolt



### Description

- Suitable for use with cables from 24 to 76mm in diameter
- Available in 33 sizes
- Can be used for all types of cable routes
- Supplied complete with top fastening
- Available as either single or two fixing design
- Plain finish for indoor dry normal industrial use or outdoor unpolluted areas
- Operating temperature: -60°C to +100°C

Single fixing: Plain finish - ATFC type

These cleats are suitable for use at a maximum fault level of 30 kA rms.

Recommended maximum spacings: straight runs 900 mm, vertical bends 300 mm and horizontal bends on each support with, if necessary, intermediate unanchored cleats to limit restraint spacing to 300mm.

### Method of Fixing

In all applications the cleats should be mounted on one M10 fixing as appropriate.

It is essential that they are secured to supports capable of withstanding the prospective short circuit forces.

Two hole fixing available on request.

Part No.	Cable Diameter (mm)	
	Min	Max
ATFC24-25	24	25
ATFC25-27	25	27
ATFC27-28	27	28
ATFC28-30	28	30
ATFC30-32	30	32
ATFC32-34	32	34
ATFC34-35	34	35
ATFC35-36	35	36
ATFC36-38	36	38
ATFC38-39	38	39
ATFC40-41	40	41
ATFC41-43	41	43
ATFC43-44	43	44
ATFC44-46	44	46
ATFC46-48	46	48
ATFC48-49	48	49
ATFC49-51	49	51

Part No.	Cable Diameter (mm)	
	Min	Max
ATFC51-53	51	53
ATFC53-55	53	55
ATFC54-56	54	56
ATFC56-57	56	57
ATFC57-59	57	59
ATFC59-60	59	60
ATFC60-62	60	62
ATFC62-64	62	64
ATFC64-65	64	65
ATFC65-67	65	67
ATFC67-68	67	68
ATFC68-70	68	70
ATFC70-72	70	72
ATFC72-73	72	73
ATFC73-74	73	74
ATFC74-76	74	76

Sold in eches

# Fixing Band



## All Round Fixing Band

The original versatile all round band with hidden inner strength. Pre-drilled, no wastage, choice to suit all environments.

### 10 Metre Coil Size

Part No.	Diameter Size (mm)	Colour/Finish
ARB12/BL	12mm	BLACK
ARB12/WH	12mm	WHITE
ARB12/RED	12mm	RED
ARB12/GA	12mm	GALVANISED
ARB12/C	12mm	COPPER
ARB12/AL	12mm	ALUMINIUM
ARB17/BL	17mm	BLACK
ARB17/WH	17mm	WHITE
ARB17/RED	17mm	RED
ARB17/GA	17mm	GALVANISED
ARB17/C	17mm	COPPER
ARB17/AL	17mm	ALUMINIUM



### Specification for Plain, Galvanised or Coated Band

Max. Working Load (kg)	Thickness (mm)	Fixing Hole Dia. (mm)
ARB12 - 185	0.9	5
ARB17 - 260	0.9	7

LSF coated available on request.

Choice of colours - black, white, red, grey, plain metal finish, galvanised, copper, stainless steel and aluminium.

Pack sizes: 10m and 3m pre-pack reels.



# HEATSHRINK & INSULATION PRODUCTS



*'Handi-Box' and Heatshrink Packs..... 100*



*Standard Grade Polyolefin Heatshrink..... 101-102*



*SG.-Green/Yellow Heatshrink..... 102*



*Heatshrink 1 metre Cartons..... 103*



*Cable Repair Sleeve..... 104*



*Dual Wall Heatshrink Tubing..... 104*



*Medium Wall Heatshrink Tubing..... 105*



*Thick Wall Heatshrink Tubing..... 106*



*Heatshrink Spreader Caps..... 107*



*Heatshrink Cable End Caps..... 108*



*PVC Sleeving..... 109*



*Heat Resistant Sleeving..... 110*

HEATSHRINK & INSULATION PRODUCTS

## Heatshrink

Standard Grade Polyolefin in 'Handi-Box' and Pack Form



### Heatshrink Packs

Part No.	Size (mm)	Shrinks to	Length
SP6EU	6.4	3.0	250mm x 5 Cols x 3 Lgths
SP12EU	12.7	6.0	250mm x 5 Cols x 3 Lgths
SP19EU	19.0	9.0	250mm x 5 Cols x 2 Lgths
SP25EU	25.0	12.0	250mm x 5 Cols x 2 Lgths
SP38EU	38.0	19.0	250mm x 5 Cols x 2 Lgths

SP EU packs contain 5 colours - Black, Blue, Brown, green/yellow, and Grey. Special requirements to order.

Part No.	Size (mm)	Shrinks to	Length
SP6	6.4	3.0	250mm x 4 Cols x 3 Lgths
SP12	12.7	6.0	250mm x 4 Cols x 3 Lgths
SP19	19.0	9.0	250mm x 4 Cols x 2 Lgths
SP25	25.0	12.0	250mm x 4 Cols x 2 Lgths
SP38	38.0	19.0	250mm x 4 Cols x 2 Lgths

SP packs contain 4 colours only - Red, Blue, Yellow and Black. Special requirements to order.

### Dual Wall (Adhesive Lined) Polyolefin Heatshrink Packs

Part No.	Size (mm)	Shrinks to	Length
SPDW6	6.4	2.2	250mm x 15 Lgths
SPDW12	12.7	4.2	250mm x 10 Lgths
SPDW25	25.0	8.5	250mm x 5 Lgths

Colour: Black



110v/240v hot air guns available.  
HAG110 (110v)  
HAG240 (240v)  
See page 175.

### 'Handi-Box'

For small quantities, an easy way of buying an assortment of coloured standard grade heatshrink incorporating colours - Red, Yellow, Blue, Green/Yellow, Black, Grey, White, Clear and Brown.



Part No.*	Internal Diameter		Wall Thickness		Box Quantity (m)
	As Supplied (mm)	After Recovery (mm)	As Supplied (mm)	After Recovery (mm)	
	Min.	Max.	Nominal.	Max.	
SG3.2*-HB	3.2	1.30	0.18	0.38	15
SG4.8*-HB	4.8	2.30	0.25	0.50	10
SG6.4*-HB	6.4	3.0	0.28	0.55	10
SG9.5*-HB	9.5	4.5	0.30	0.60	10
SG12.7*-HB	12.7	6.0	0.30	0.60	10
SG19*-HB	19.0	9.0	0.40	0.80	5
SG25*-HB	25.0	12.0	0.55	0.90	5

\*Please specify colour required after Part No.



## Standard Grade Polyolefin Heatshrink

### 2:1 Shrink Ratio

SG.- Standard Grade Polyolefin, 2:1 shrink ratio, shrink with hot airgun or naked flame, flexible, excellent insulation properties, easily printed on, without adhesive and does not melt-resistant to cold flow.

#### Application:

SG is a flexible, flame-retardant heat shrinkable polyolefin tubing designed for a wide range of applications such as insulation, marking, strain relief and mechanical protection.

#### Specifications:

- UL224 125°C 600V VW-1
- CSA C22.2 No. 198 125°C 600V
- RoHS Compliant

#### Shrinking Properties:

- Radial shrinkage: 50% min
- Longitudinal shrinkage: 5% max
- Tubing has ability to shrink at comparatively low temperatures of 100°C
- 2:1 shrink ratio
- Operating temperature: -55°C to 125°C
- Self-extinguishing

### STANDARD SIZES

Part No.*	Size (mm)	'Layflat' (mm) (nominal)	Inside Diameter (mm)		Wall Thickness (mm)		Reel Length (m)
			as supplied (average)	after recovery (maximum)	as supplied (nominal)	after recovery (maximum)	
SG1.2	1.2	-	1.4	0.60	0.20	0.36	200
SG1.6	1.6	-	2.0	0.75	0.20	0.44	200
SG2.4	2.4	-	2.5	1.00	0.20	0.44	100
SG3.2	3.2	5	3.4	1.50	0.25	0.44	100
SG4.8	4.8	8	5.0	2.25	0.25	0.56	100
SG6.4	6.4	11	6.5	3.00	0.25	0.56	100
SG9.5	9.5	17	9.8	4.50	0.25	0.56	100
SG12.7	12.7	21	12.5	6.00	0.25	0.56	100
SG19	19.1	31	19.3	9.00	0.35	0.77	50
SG25	25.4	44	25.5	12.5	0.45	0.87	50
SG38	38.0	60	39.0	19.0	0.50	0.97	50
SG50	50.0	83	51.0	25.0	0.50	0.97	50
SG75	75.0	128	76.2	38.1	0.50	0.97	50
SG100	100.0	160	101.6	50.8	0.50	0.97	50

\* Suffix colour required. For technical data contact SWA. Larger sizes available on request. Sold on reels or cut to size. Colours available: Black, blue, yellow, red, white, clear, brown, grey - other colours on request. Wall thickness will be less if tubing recovery is restricted during shrinkage.

Available in cut lengths

For Green/Yellow - refer to page 109



## Sizing Chart Guide

Standard Grade Polyolefin Heatshrink to cover 6491X / 6181Y Type Cable

Cable Size (mm <sup>2</sup> )	6491X	6181Y	Cable Size (mm <sup>2</sup> )	6491X	6181Y
1.5	SG4.8	SG64	95	SG19	SG25
2.5	SG4.8	SG64	120	SG25	SG25
4.0	SG6.4	SG95	150	SG25	SG38
6.0	SG6.4	SG95	185	SG25	SG38
10	SG9.5	SG12	240	SG38	SG38
16	SG9.5	SG12	300	SG38	SG38
25	SG12	SG19	400	SG38	SG50
35	SG12	SG19	500	SG50	SG50
50	SG19	SG19	630	SG50	SG50
70	SG19	SG25			

## Standard Grade Polyolefin (green/yellow)

Green and yellow striped, flexible polyolefin sleeving

### Application:

SG-G/Y is a general purpose, flexible polyolefin tubing for a wide range of applications such as insulation, strain relief, light-duty harnessing or where the international electrical ground designation is intended.

### Features:

- Shrink ratio 2:1
- Minimum shrink temperature: 90°C
- Operating temperature: -30°C to +125°C
- Flammability: UL VW-1
- UL224 (Reference standard)



### STANDARD SIZES

Part No.	'Layflat' (mm) (nominal)	Inside Diameter (mm)		Wall Thickness (mm)		Reel Sizes (m)
		as supplied (average)	after recovery (maximum)	as supplied (nominal)	after recovery (maximum)	
SG3.2 G/Y	5	3.4	1.50	0.25	0.50	100
SG4.8 G/Y	8	5.0	2.25	0.25	0.59	100
SG6.4 G/Y	11	6.5	3.00	0.25	0.56	100
SG9.5 G/Y	17	9.8	4.50	0.25	0.68	100
SG12.7 G/Y	21	12.5	6.00	0.25	0.68	100
SG19 G/Y	31	19.3	9.00	0.35	0.77	50
SG25 G/Y	44	25.5	12.5	0.45	0.90	50
SG38 G/Y	60	39.0	19.0	0.50	1.04	50
SG50 G/Y	83	51.0	25.0	0.50	0.97	50

Available in cut lengths



## Standard Grade & Dual Wall Polyolefin

Shrink Ratio - Standard Colours 3:1  
Green/Yellow 2:1

Supplied boxed in 1m lengths

Part No.	Description	PSC/CTN
SG6CTN-BLK	H/S Carton 6.4mm Black	50
SG6CTN-BLU	H/S Carton 6.4mm Blue	50
SG6CTN-BRO	H/S Carton 6.4mm Brown	50
SG6CTN-G/Y	H/S Carton 6.4mm Green/Yellow	50
SG6CTN-GREY	H/S Carton 6.4mm Grey	50
DW6CTN	Dual wall adhesive lined heathrink 6.4mm (Black)	50
SG12CTN-BLK	H/S Carton 12.7mm Black	20
SG12CTN-BLU	H/S Carton 12.7mm Blue	20
SG12CTN-BRO	H/S Carton 12.7mm Brown	20
SG12CTN-G/Y	H/S Carton 12.7mm Green/Yellow	20
SG12CTN-GREY	H/S Carton 12.7mm Grey	20
DW12CTN	Dual wall adhesive lined heathrink 12.7mm (Black)	20
SG19CTN-BLK	H/S Carton 19mm Black	10
SG19CTN-BLU	H/S Carton 19mm Blue	10
SG19CTN-BRO	H/S Carton 19mm Brown	10
SG19CTN-G/Y	H/S Carton 19mm Green/Yellow	10
SG19CTN-GREY	H/S Carton 19mm Grey	10
DW19CTN	Dual wall adhesive lined heathrink 19mm (Black)	10
SG25CTN-BLK	H/S Carton 25.4mm Black	10
SG25CTN-BLU	H/S Carton 25.4mm Blue	10
SG25CTN-BRO	H/S Carton 25.4mm Brown	10
SG25CTN-G/Y	H/S Carton 25.4mm Green/Yellow	10
SG25CTN-GREY	H/S Carton 25.4mm Grey	10
DW25CTN	Dual wall adhesive lined heathrink 25mm (Black)	10

- Dual wall now added to the merchandiser range
- All heatshrink sleeving supplied in carton quantities only



Display stand available  
ref: HSM15 (stand only)



110v/240v hot air guns available.  
HAG110 (110v)  
HAG240 (240v)  
See page 175.

## Cable Repair Sleeve - Adhesive Lined



### Application

Quick and simple to use cable repair sleeve. Thermoplastic adhesive.

### Features

- Medium wall, halogen free
- Internal pressure max. 1.5 bar
- With hot melting adhesive
- High tensile strength
- Resistant to cold flow
- Very good chemical and electrical properties
- UV resistant
- Non-corrosive
- Minimum shrink temp: 125°C
- Operating temp: -40°C to +120°C
- Colour: black only

Part No.	Max. (mm)	Min. (mm)	Wall thickness after shrink (mm)	Length (mm)
SRMAHV28-10	28	10	2.3	1500
SRMAHV43-12	43	12	3.4	1500
SRMAHV72-18	72	18	3.4	1500
SRMAHV93-26	93	26	3.4	1500
SRMAHV115-30	115	30	2.3	1500
SRMAHV125-32	125	32	2.3	1500

## Dual Wall Adhesive Lined Tubing

### 3:1 Shrink Ratio

#### Application:

DW is a general purpose, flexible polyolefin tubing with an adhesive liner that will melt and flow to seal and encapsulate the inner components offering environmental protection. Few sizes cover a wide range of diameters allowing reduced inventory and this tubing will accommodate awkward irregular shapes.



#### Features:

- Shrink ratio 3:1
- Minimum shrink temperature: 90°C
- Operating temperature: -55°C to +125°C
- Flammability: UL VW-1 (outer layer only)
- UL224 (Reference standard)
- RoHS Compliant

### STANDARD SIZES

Part No.	Inside Diameter (mm)		Wall Thickness (mm)		Standard Length (m)
	as supplied (average)	after recovery (maximum)	as supplied (nominal)	after recovery (maximum)	
DW48	4.8	1.6	0.48	1.10	1.2
DW64	6.4	2.2	0.50	1.20	1.2
DW95	9.5	3.2	0.55	1.45	1.2
DW12	12.7	4.2	0.68	1.70	1.2
DW19	19.1	6.3	0.76	2.00	1.2
DW25	25.4	8.5	0.78	2.10	1.2
DW38	38.0	13.5	0.85	2.40	1.2



110v/240v hot air guns available.  
HAG110 (110v)  
HAG240 (240v)  
See page 175.

## Medium Wall Tubing

### 3:1 Shrink Ratio

#### Application:

Polyolefin sleeving suitable for insulating, pressure and humidity tight sheathings. Suitable for cable joints and terminations.



#### Features:

- Medium wall, halogen free
- Shrink ratio 3:1
- SR2 without hot-melt adhesive
- SRH2 with hot-melt adhesive
- High tensile strength
- Resistant to cold flow
- Very good chemical and electrical properties
- Non-corrosive
- U.V resistant
- Minimum shrink temperature: 125°C
- Operating temperature: -40°C to +120°C
- Cross linked polyolefin, free of lead and cadmium
- Colour: black
- RoHS Compliant

### STANDARD SIZES

Part No. With Adhesive	Part No. Without Adhesive	Size (mm)	After Shrinkage (mm)	Wall Thickness After Shrinkage (mm)	Standard Lengths (m)
SRH2-12-3	SR2-12-3	12	3	2.2	1 & 1.2
SRH2-22-6	SR2-22-6	22	6	2.6	1 & 1.2
SRH2-34-7	SR2-34-7	34	7	2.6	1 & 1.2
SRH2-40-12	SR2-40-12	40	12	2.6	1 & 1.2
SRH2-56-16	SR2-56-16	56	16	2.7	1 & 1.2
SRH2-75-22	SR2-75-22	75	22	3.0	1 & 1.2
SRH2-95-26	SR2-95-26	95	26	3.2	1 & 1.2
SRH2-120-34	SR2-120-34	120	34	3.3	1 & 1.2

Add: -1 to part no. for 1m lengths  
-2 to part no. for 1.2m lengths



110v/240v hot air guns available.  
HAG110 (110v)  
HAG240 (240v)  
See page 175.

## Thick Wall Tubing



### 3:1 Shrink Ratio

#### Application:

Polyolefin sleeving suitable for insulating, pressure and humidity tight sheathings. Suitable for cable joints and terminations.



#### Features:

- Thick wall, halogen free
- Shrink ratio 3:1
- SR3 without hot-melt adhesive
- SRH3 with hot-melt adhesive
- High tensile strength
- Resistant to cold flow
- Very good electrical and chemical properties
- Non-corrosive
- U.V resistant
- Minimum shrink temperature: 125°C
- Operating temperature: -40°C to +120°C
- Cross linked polyolefin, free of lead and cadium
- Colour: black
- RoHS Compliant

### STANDARD SIZES

Part No. With Adhesive	Part No. Without Adhesive	Size (mm)	After Shrinkage (mm)	Wall Thickness After Shrinkage (mm)	Standard Lengths (m)
SRH3-12-3	N/A	12	3	2.6	1 & 1.2
SRH3-22-6	SR3-22-6	22	6	2.7	1 & 1.2
SRH3-33-8	SR3-33-8	33	8	4.0	1 & 1.2
SRH3-45-12	SR3-45-12	45	12	4.4	1 & 1.2
SRH3-55-15	SR3-55-15	55	15	4.4	1 & 1.2
SRH3-75-20	SR3-75-20	75	20	4.5	1 & 1.2
SRH3-92-25	SR3-92-25	92	25	4.6	1 & 1.2
SRH3-130-34	SR3-130-34	130	34	4.8	1 & 1.2

Add: -1 to part no. for 1m lengths  
-2 to part no. for 1.2m lengths



110v/240v hot air guns available.

HAG110 (110v)

HAG240 (240v)

See page 175.



## Heatshrink Spreader Caps

### Application:

Spreader caps are designed for the insulation and pressure proof sealing of cable crutches and provide resistance to abrasion, weathering and chemical attack. Shrink parts must be selected about 5mm larger than the cable diameter.



### Features:

- Highly flame retardant material
- With hot-melt adhesive to prevent moisture and contaminants ingress
- Pressure and humidity proof
- Outstanding mechanical, chemical and electrical properties
- U.V resistant
- Minimum shrink temperature: 125°C
- Operating temperature: -30°C to +135°C
- Cross linked polyolefin, free of lead, cadmium and halogen
- Unlimited storage life
- Colour: black
- RoHS Compliant

### STANDARD SIZES

Part No.	No. of Cores (mm)	O.D of Core (mm)	I.D of Core (mm)	Length of Cap (mm)	Length of Leg (mm)	Wall Thickness After Shrink (mm)
HSC2-30-15	2	30	15	65	22	1.5
HSC2-50-12	2	50	21	85	28	3.0
HSC2-87-43	2	87	43	95	25	3.0
HSC3-25-9	3	25	9	45	30	2.5
HSC3-55-31	3	55	30	115	30	3.0
HSC3-72-37	3	82	36	130	35	4.0
HSC3-110-35	3	110	40	145	35	4.0
HSC4-28-9	4	28	9	50	15	2.7
HSC4-35-12	4	35	15	75	15	3.0
HSC4-47-23	4	47	21	110	30	4.1
HSC4-60-23	4	60	30	125	35	4.1
HSC4-78-36	4	78	38	145	35	4.0



110v/240v hot air guns available.  
 HAG110 (110v)  
 HAG240 (240v)  
 See page 175.



## Heatshrink Cable End Caps

### Application:

Cable end caps are designed to seal the end of cables and protect them against the ingress of moisture and contamination. They can provide pressure and humidity proof sealing of cables and conduit.



### Features:

- With hot-melt adhesive to prevent moisture and contamination ingress
- Pressure and humidity proof
- Outstanding mechanical, chemical and electrical properties
- U.V resistant
- Minimum shrink temp: 125°C
- Operating temp: -30°C to +135°C
- Cross linked polyolefin, free of lead, cadmium and halogen
- Unlimited storage life
- Colour: black
- RoHS Compliant

### STANDARD SIZES

Part No.	Internal Dia. Before Shrink. (mm)	Max Dia. After Shrink. (mm)	Length of Cap (mm)	Wall Thickness After Shrink. (mm)
HEC10-4	10	4	34	2.0
HEC16-6	16	6	40	2.0
HEC25-9	25	9	70	2.5
HEC26-11	26	11	65	3.0
HEC40-17	40	17	100	3.5
HEC57-22	57	22	130	4.0
HEC75-32	75	32	150	5.2
HEC105-45	105	45	160	7.0
HEC148-57	148	57	154	7.0
HEC158-63	158	63	170	7.0



110v/240v hot air guns available.

HAG110 (110v)

HAG240 (240v)

See page 175.

# Insulation Sleeving

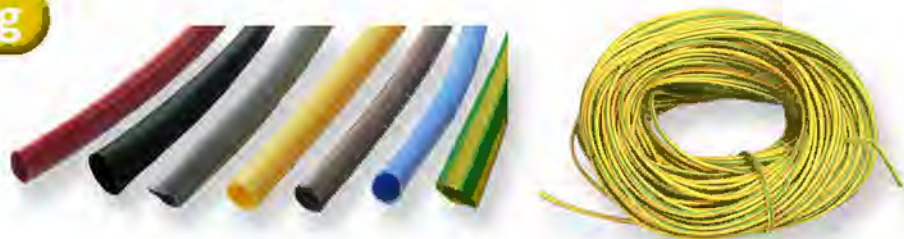

## PVC Sleeving

### Description:

PVC sleeving is supplied in a wide range of sizes and colours. In addition to the size range shown we can supply alternative diameters and wall thickness to meet particular applications as required. A versatile material in common use ideal for cable or harnessing covering.

Continuous operating temp: -20°C to 70°C

Insulation resistance: 10<sup>10</sup> Ohm/cm

Dielectric Strength: 20kV/mm

Tensile Strength: 15MPa

Elongation at break: 220%

Hardness: BSS20-30

Flammability: Self-extinguishing

RoHS compliant

Hanks Part No.	Reel Part No.	Internal Diameter (mm)	Nominal Wall Thickness (mm)	Coil Size (metres)
PVC1.5*	N/A	1.5	0.5	100
PVC2*	PVC2*-REEL	2.0	0.5	100
PVC3*	PVC3*-REEL	3.0	0.5	100
PVC4*	PVC4*-REEL	4.0	0.5	100
PVC5*	N/A	5.0	0.5	100
PVC6*	N/A	6.0	0.5	100
PVC8*	N/A	8.0	0.5	100
PVC10*	N/A	10.0	0.5	100
PVC12*	N/A	12.0	0.5	100



Reel

\* Suffix Part No. with the colour required e.g. green/yellow = PVC3G/Y

NB. 85°C and 105°C rated sleeving only available to special order.

Can be supplied in alternative wall thickness or on reels to special order.

All sizes available in cut lengths (subject to minimum order quantities).

Standard colours: black (BLK), red (RED), blue (BLU), white (WHI), green/yellow (G/Y), brown (BRO), yellow (YEL) and grey (GRY).

Other sizes and colours available may be subject to minimum order - green, violet, orange, pink and clear.

### PVC Sleeving 5 metre Packs

Part No.			Colour
3mm Internal Diameter	4mm Internal Diameter	6mm Internal Diameter	
BLK3-P5M	BLK4-P5M	BLK6-P5M	Black
BLU3-P5M	BLU4-P5M	BLU6-P5M	Blue
BR3-P5M	BR4-P5M	BR6-P5M	Brown
GREY3-P5M	GREY4-P5M	GREY6-P5M	Grey
RED3-P5M	RED4-P5M	RED6-P5M	Red
GY3-P5M	GY4-P5M	GY6-P5M	Green/Yellow

# Insulation Sleeving



## Heat Resistant Sleeving

Acrylglass is a saturated acrylic braided glass sleeving designed for thermal protection of hose, pipes and cable assemblies. The braided tubular glass reinforced has a construction that allows a degree of expansion and is manufactured from 'E' glass yarn.

The glass sleeve is coated with an acrylic resin, which is solvent free and provides a high operating temperature and resistance to automotive related and other fluids.

### Application:

Thermal protection of: cables, wires - low voltage  
 Applications: automotive wiring, domestic appliances,  
 class F induction motors, winding leads out,  
 joints 1kV.

### Technical Data:

Flammability: Non-burning. Glass yarns are incombustible.  
 Operating temperature: 155°C  
 Heat shock: (4 hours at 155°C) no dripping or flowing.  
 Electric strength at 20°C: 1.0kV/1 min. IEC684-2

### Features:

- Diameters 0.5 - 20mm
- Self-extinguishing
- Operating temperature 155°C
- Electric strength 1.0kV
- Low thermal conductivity
- Retains mechanical properties at high temp
- Rot proof, resistant to fungus
- Resistance to many fluids
- Supplied in coils, reels, cut lengths and packs
- RoHS Compliant

Part No.	Nominal Bore (mm)	Wall Thicknes (mm)	Standard Coil Length (m)
HRS4	4.0	0.4	200
HRS6	6.0	0.5	200
HRS8	8.0	0.8	100
HRS10	10.0	0.8	100
HRS12	12.0	0.9	100
HRS16	16.0	0.9	50

Larger sizes available on request subject to M.O.Q  
 Colours: up to HRS6 - black (B), red (R), brown (BRO) and blue (BLU)  
 HRS8 and above - black and red only.  
 Sold per metre.

Part No.	Nominal Bore (mm)	Contents
HRS2 PACK	2.0	1m x red sleeve, 1m x black sleeve
HRS4 PACK	4.0	1m x red sleeve, 1m x black sleeve
HRS6 PACK	6.0	1m x red sleeve, 1m x black sleeve
HRS4EU PACK	4.0	1m x blue sleeve, 1m x brown sleeve
HRS6EU PACK	6.0	1m x blue sleeve, 1m x brown sleeve



# CABLE MANAGEMENT



*Spiral Wrap Binding..... 112*



*Expandable 'Push-back' Cable Jacketing..... 112*



*Polypropylene Corrugated Conduit..... 113*



*Standard Flexible Conduit..... 113*



*Economy Flexible Conduit..... 114*



*Flexible Conduit (Galvanised Steel PVC Coated)..... 114*

# Cable Management

## Spiral Wrap Binding

- Material: Polyethylene. (PE)
- Application: An easy and economical way of bundling cables and harnesses and providing harness breakouts. Wrap clockwise to apply.
- Features: Flexible and easy to install. Durable, abrasion resistant, reusable with retained spiral strength  
- won't change shape after second usage.
- Temperature range: -30°C to +80°C
- Flammability: UL94HB

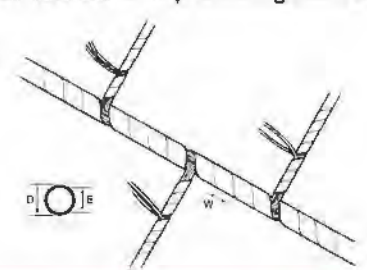

Part No.	Internal Dia. (mm) E	External Dia. (mm) D	Bundle Dia (mmØ)	Coil Size (m)
SP4*-10	5.0	6	4-50	10
SP6*-10	7.0	8	6-60	10
SP9*-10	10.2	12	9-65	10
SP12*-10	13.0	15	12-70	10
SP15*-10	16.4	19	15-100	10
SP20*-10	21.0	24	20-130	10

\* Add suffix to part no. to denote colour required: N - natural, B - black

## Expandable 'Push-back' Cable Jacketing

- Ideal product to support and protect cable harnesses
- Offers superb flexibility
- Available in black or grey

Fumes Toxicity: Passes CEI 754-1  
and CEI 754-2 Halogen free

Fumes Opacity: Passes NF C 20452 (Polymer)

Chemical Resistance: Unaffected by most chemicals

### Properties:

Monofilament: Polyester - size 0.22mm

Melting Point: +250°C

Limiting Oxygen Index: 34%

Working Temperature: -50°C to +150°C

Whitland Peaks: 220°C

Flame Resistance:

Passes flame requirement of CEI 332-1

and FMVSS 302 (Type A)

12 according to NF F 16-101



Part No.	Size (mm)		Coil Size (m)
	Normal	Expanded	
PBJ5*-100	5	10	100
PBJ10*-100	10	18	100
PBJ12*-50	12	20	50
PBJ15*-50	15	25	50
PBJ20*-25	20	38	25
PBJ25*-25	25	46	25
PBJ30*-25	30	55	25
PBJ40*-25	40	75	25

\* Suffix part number BLK (black) or GRY (grey).

# Cable Management

## Polypropylene Corrugated Conduit



FCP series corrugated conduit is a very economical solution for a variety of applications due to its high flexibility, compression strength and colour range.

Suitable for embedding into floors and walls, the FCP series is often used for cable assemblies, underfloor wiring and cable tidying.

### Features:

- Made from polypropylene
- Temperature range from -40°C to +120°C
- Black in all sizes, colours available in 20, 25 and 32mm only
- LSZH (Low Smoke Zero Halogen), UL resistant
- IP54

### Install Instruction

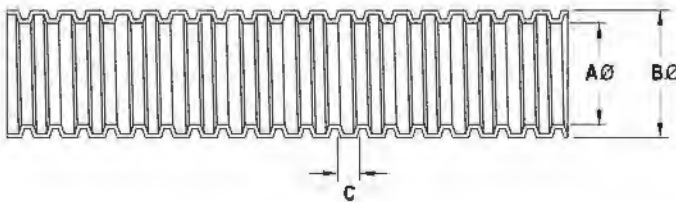
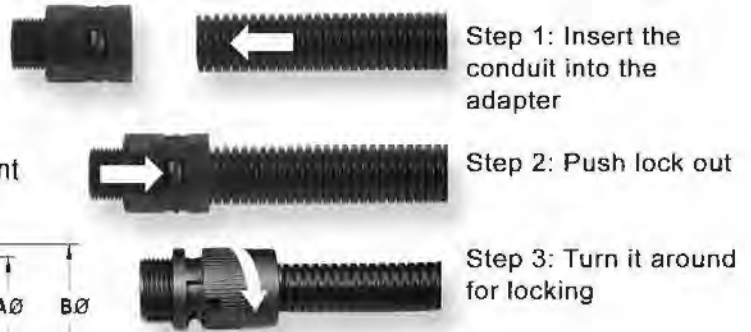

Part No.	Trade Size (mm)	Internal Diameter (mm)	External Diameter (mm)	Coil Size (m)	Adaptors	Pack Qty
<b>FCP16-100</b>	16	10.7	16.0	100	<b>FCA-16PN</b>	50
<b>FCP20-100</b>	20	16.8	20.0	100	<b>FCA-20PN</b>	50
<b>FCP25-100</b>	25	19.9	25.0	100	<b>FCA-25PN</b>	50
<b>FCP32-50</b>	32	26.5	32.0	50	<b>FCA-32PN</b>	50

The above part numbers are based on black colour. For other colours, suffix part number with -W (white), -G (grey), -OR (orange), -GN (green), -Y (yellow) e.g. FCP20-W. Available with matching colour adaptors. Please note that colours are only available for 20mm, 25mm and 32mm



Standard Conduit



Contractor Pack

## Flexible Conduit Contractor Pack

Part No.		Dimensions mm			Pack Contents
Nylon	Polyprop.	A Ø	B Ø	C	
<b>FCN20-PK10</b>	<b>FCP20-PK10</b>	14.1	20.0	3.70	10m + 10 adaptors
<b>FCN25-PK10</b>	<b>FCP25-PK10</b>	18.3	25.0	4.10	10m + 10 adaptors

Standard colour: Black. Also available in white.

# Cable Management

## Economy Flexible Conduit

- Polypropylene conduit for running cable protection in electrical machinery or harness wiring
- Flexible body facilitates easy cornering

### Contractor Packs

Part No.	Internal Dia. mm	O/D mm	Colour	Pack Contents
FCP20-PK10-E	14	20	Black	10m + adaptors + locknuts
FCP25-PK10-E	18	25	Black	10m + adaptors + locknuts
FCP20W-PK10-E	14	20	White	10m + adaptors + locknuts
FCP25W-PK10-E	18	25	White	10m + adaptors + locknuts



## Plain Galvanised Steel Conduit

- **Temperature range** from  $-50^{\circ}\text{C}$  to  $+500^{\circ}\text{C}$
- Conforms to BS EN 61386 • IP40, Inherent Low Fire hazard • RoHS Compliant

Part No.	Trade Size	Dimensions mm		Minimum Bent Radius	Coil Size
		A Ø	B Ø		
FGC20	20	17	20.5	38	50m
FGC25	25	21	25	45	50m
FGC32	32	28.5	32	55	50m

Standard colour: black PVC.

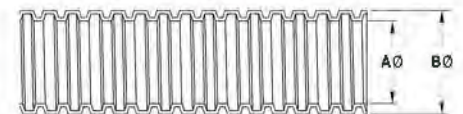

Part No.	Description	Size	Pack Contents
CF-20S	Conduit swivel adaptor	M20 x 1.5	Each
CF-25S	Conduit swivel adaptor	M25 x 1.5	Each
CF-32S	Conduit swivel adaptor	M32 x 1.5	Each
CF20S-90E	Conduit elbow swivel adaptor	M20 x 1.5	Each
CF25S-90E	Conduit elbow swivel adaptor	M25 x 1.5	Each
CF32S-90E	Conduit elbow swivel adaptor	M32 x 1.5	Each



Elbow swivel adaptors

Swivel adaptors

## Galvanised Steel PVC Covered - Contractor Packs

- For running cable protection in electrical, machinery and harness wiring
- Good mechanical protection
- Ideal for extremely wet or damp conditions, cold storage areas
- Provides protection against most liquids
- Flexible body facilitates easy cornering or elbow applications
- Available in standard coils or contractor packs complete with adaptors

**Temperature rating:**  $0^{\circ}\text{C}$  to  $+90^{\circ}\text{C}$

Part No.	Dimensions mm		Pack Contents
	A Ø	B Ø	
FCPVC/GAL20-PK10	17	21	10m + 10 adaptors
FCPVC/GAL25-PK10	21	26	10m + 10 adaptors

Standard colour: black PVC.



# CABLE JOINTING



**LLFA® Tape..... 116-118**



**Cellpack Resin Cable Joint Kits..... 119-137**



**Cellpack Jointing Accessories..... 137**



**Universal Termination Box..... 138**



**Heatshrink Joint Kits..... 139**



**Mechanical Cable Connectors..... 140-142**



**Line Taps..... 143**



**Underground Marking Tape..... 144**



**Cable Protection Tiles..... 144**

# Cable Jointing

## LLFA® Compression Tape

**ΔFA**

Repairs, seals and insulates in seconds!



REPAIR

INDUSTRIAL



SEAL

MAINTENANCE



INSULATE

ELECTRICAL

Saving time, this rapidly applied solution, is saving money. Multipurpose industrial grade solution used to create high tension seals with exceptionally long life. This is one product that will deliver every time.

Repairs, seals and insulates. One product with many uses. For a multitude of applications, LLFA Tape is an effective yet robust repair that is waterproof, weatherproof, easily applied and endures extreme conditions.

Outstanding performance for high or low voltage insulation. Long lasting, water tight and robust. Used for bus bar insulation, cable jointing, connection weather proofing, and cable repair.

Compression Tape combines ultra fast self-fusion with high tensile strength

Approvals: BS EN50393:2006, BS EN150 4589-2:199, BS 6920:2000

**WRAS**  
APPROVED  
PRODUCT

- Water tight electrical cable jointing and termination
- Leaking pipe repair without reducing the pressure or turning off the flow
- High voltage insulation
- Highly UV resistant
- Exceptional lifespan even when buried or submersed
- Functions in low or high temperatures
- Non-toxic, safe for use in direct contact with drinking water
- Easily applied, instant repair
- Environmentally responsible, replacing hazardous materials
- Saves time and money

SEAL - **stretch** to Maximum (300%)

FINAL LAYER - Minimum Stretch



Scan to view Plumbing  
LLFA Tape demo



Scan to view Electrical  
LLFA Tape demo





Repairs, seals and insulates in seconds!



REPAIR

INDUSTRIAL



SEAL

MAINTENANCE



INSULATE

ELECTRICAL

## LLFA® Compression Tape

A self fusing tape utilised to insulate and seal electrical cable splices where high and low temperature stability is needed, and where moisture, weather and radiation resistance is required.

Mechanically it provides a high tension wrap that creates an enduring seal under extreme environmental conditions. Due to its remarkable properties, it is also used to repair punctured water, air and hydraulic pipes that are subject to pressure and temperature variants.



LLFA 40/1 Black



LLFA 40/1 Red

Part No.	Length (m)	Width (mm)
LLFA 40/1 Black	10.9	25.4
LLFA 40/1 Red	10.9	25.4
LLFA 12/1 Black	3.6	25.4
LLFA 12/1 Red	3.6	25.4



LLFA 12/1



Free dispenser supplied with 10 rolls of LLFA 12/1 (red or black)

## LLFA® 1m Dispenser Pack

1m length of LLFA 40/1 black/red tape cut into 3 equal lengths.

Single Pack	Part No.	Box of 25 Packs
L40PK1M Black	L40PK1mBLK-BX (Black)	
L40PK1M Red	L40PK1mRED-BX (Red)	



## LLFA® Smooth

An insulating putty that is soft enough to mould into any cavity or change in diameter, yet consistent enough to hold its shape once applied. It is primarily used to prepare a ready surface to which LLFA® TAPE can be applied.

Part No.	Pack Wt (g)
LSP320	113



Repairs, seals and insulates in seconds!



INDUSTRIAL



MAINTENANCE



ELECTRICAL

## LLFA® Compression Tape

LLFA® Compression Tape can be used as a stand alone product. It seals when applied with "maximum stretch", and gives mechanical protection when applied with "minimum stretch".

### Fusion

With LLFA® Compression Tape fusion is almost instantaneous. This is an important factor when splicing or protecting a connection that is subject to high humidity or even submergence.

### Electrical Insulation

Straight and branch joints spliced with LLFA®, from the smallest to the biggest cable size, have undergone European standard testing to BS EN 50393:2006. This jointing method has successfully met all the requirements of the standard to make it the first compression tape jointing solution available in the EU.

### Instant Leak Repair

LLFA® Compression Tape is used to repair leaking pipes without turning off the flow. A punctured hose or pipe tightly wrapped with LLFA® Compression Tape will immediately withstand internal pressure. The pressure will not push between the "fusing layers" because the fusion takes place so quickly (even when wet).

### Abrasion Resistance

LLFA® Compression Tape, due to its unique formulation and manufacturing process, is resistant to abrasion and split propagation. Applying a final layer with minimum tension will increase abrasion resistance.

### Temperature Stability

Other products decrease or lose adhesion in extreme cold or humid conditions. LLFA® Compression Tape as a "CLASS H" material will continue to perform at these temperatures. LLFA® does not have to be kept warm in the cold or vice versa.

### Environmentally Responsible

LLFA® Compression Tape is environmentally friendly and is replacing solutions that are hazardous. LLFA® Compression Tape is also classed as normal waste, and is approved by the Water Regulations Advisory Scheme for use in direct contact with drinking water, both hot and cold.

**Dielectric Strength** LLFA®40 = 400VPM (16,000V per 1mm)

**Tensile Strength** > 1200 PSI throughout temp range

**Breaking Strength** > 15 lbs

**Tear Resistance** > 125 PSI

**Water Absorption** << 0.5%

**Temperature Range** -90°C through to 260°C

**Elongation** > 325%

**Track Resistance** Prevent electrical conduction along its surface

**UV Resistance** Highly UV resistant

**Ozone Resistance** Highly ozone resistant

**Durometer Hardness** 55 - 65

**Adhesion (Fusion)** Standard requirement: "Tape shall not unwind more than 1.0 inch after 3 minutes with an attached load of 600g". Result: LLFA® Tape < 1 inch

**Acids and Alkaline** No negative effect from brief exposure to acid and alkaline and can withstand submersion up to 3 days

**Self Extinguishing** UL standard 94 rating V-0. Tested to IEEE383 and IEEE1212 for flammability - self extinguishes and will not propagate a flame

**Smoke Toxicity** NF X 70 - 100:2006 test results indicate a C.I.T. value of 5.20. BS6853: 1999: Annex B test results indicate an R-value of 0.37

**Water Safety** BD6920 results indicate that LLFA® Tape is suitable for use in direct contact with drinking water up to 85°C (WRAS Approved)

**Standard Compliance** BS EN50393:2006, BS6920, ASTM D2240, A-A-59163, ASTM D-149, ASTM D-412, MIL-I-46852, ASTM D2148, ASTM D3767 (LLFA® specifications meet other international standards not included in this list)

N.B. Full material safety data sheet available on request



# CELLPACK

Cast-resin Technology

### General

High quality joint components are vital for the safe functioning of a cable network. Cellpack products offer a wide range of cast-resin systems which can be used to make straight-through, transition or branch joints for low voltage or signal cables. You can install with confidence, knowing that over a million Cellpack kits have been installed worldwide over the past forty years. This long track record provides the user with high quality reliable products.



### A proven system

**The resin is pure and not sand filled.**

Every joint kit is supplied with the following components:

- Mechanically stable, self sealing, UV resistant moulds
- Cast resin and hardener mixed precisely in a two chamber mixing bag
- All the essential parts - earthing accessories, funnels, insulation tape & installation instructions

Additional accessories are supplied with certain kits - e.g. splices and mechanical connectors. See individual catalogue page for details.

### Your benefit

- Easy, time and cost saving installation
- Shelf life guarantee of 18 up to 40 months (depending on cast resin type purchased)
- Connections are water tight
- The joint is fully operational immediately after installation

### Applications

The Cellpack cast-resin system can be used for the following applications:

- Low voltage cables up to 1 kV
- Telecommunications and signal cables

## CELLPACK

### Cast-resin Technology

#### Moulds

The standard moulds used in the cast resin systems are made of thermoplastic synthetic materials, which provide the following properties:

- Excellent mechanical stability
- Highly resistant to water, watery solutions and diluted acids

The cast resin filled moulds have a shape which permits the cable installations in earth, ducts, and conduits, in water and on cable struts. The moulds are transparent which permit a visual check of the cable connection during pouring.

Cellpack cast resin moulds are shock resistant. The moulds lock into each other due to the snap on mechanism, additional fixing is therefore not necessary. The moulds also help in maintaining stability for softer cast resin (e.g. FG, WG and KG resins)

#### Cast resin

The resins can withstand several types of requirements when used for power, telecommunications and signal cable applications. Cellpack manufacture several types of cast resins which have various properties and application possibilities.

Most of our resins are delivered with a two chamber mixing bag which permits (after mixing) an easy pouring of the liquid. Prior to pouring, the two components are mixed together. The mould and the poured in resin form a complete self supporting system which protects and insulates the connection against humidity and external factors.

Generally the resins have a limited shelf life. Additionally one must be aware that the resins when mixed have a potting time which has to be respected.

#### Two Chamber Mixing Bag

The Cellpack's two chamber mixing bags have a parting rail when opened, the resin and hardener can be mixed together in a closed environment. Hardener and resin can be poured easily together. The system is protected while mixing against external dirt and other foreign materials. The two components are mixed in such a way that very little amounts of non bound material remains in the system which gives the installer a safe and environment-friendly solution.

It is recommended to handle the mixing bags with care and wear gloves while working with them. After the cast resin has been poured the remaining hardened material can be thrown away in the household waste. Non hardened material must be disposed of as hazardous waste.

The Cellpack bags are made of a three layer laminated aluminium – plastic laminate material. The material is impermeable to gas and water therefore protected against air and humidity.

The bags are welded in several locations to give it mechanical stability and can resist high pressures.

Practical two chamber mixing bag

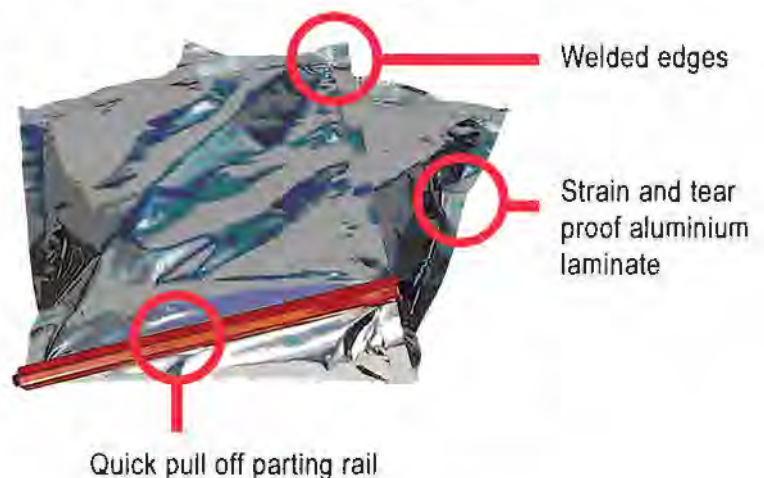

## Cable Jointing

# CELLPACK

### Cellpack Straight Cable Joints



Voltage Level: 1.2 kV

Application: Universally suitable to connect low voltage plastic-insulated cables or connectors insulated with PVC, PE, VPE, and EPR.

Suitable for both copper and aluminium conductors.

Application Ranges: Indoor, outdoor, underground, water (e.g submersible pumps), cable trays.

- Features:
- High electrical insulation values
  - Watertight both longitudinally and transversely
  - High mechanical strength
  - Good resistance against UV radiation, alkaline earths and chemical agents
  - Standard resin storable up to 40 months in the aluminium bag
  - Halogen-free polyurethanic cast resin, containing the correct volume ready for mixing within a handy two-chamber mixing bag. No need for skin contact
  - Low hardening temperature, fast hardening with no toxic emission during the mixing and casting
  - High quality, transparent, shockproof polycarbonate moulds, compact size
  - Visible splice position before casting
  - Large insertion opening for easy casting
  - Extremely simple and fast fitting - saves time and costs
  - Immediately operational

Tests and Approvals: DIN VDE 0278 Part 1 and 2, DIN VDE 0278 PART 393, EN 50393 as well as CENELEC HD623 (VDE 0278, PART 623)

### Mould Dimensions

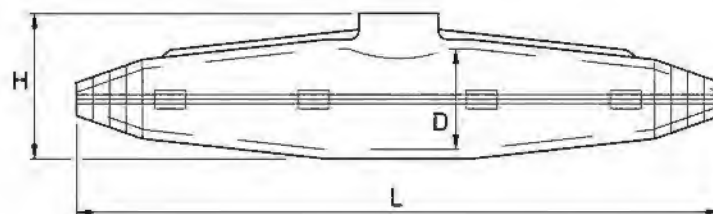

Part No.	L (mm)	D (mm)	H (mm)
SJK1516	260	47	63
SJK1	190	36	50
SJK2	260	47	63
SJK3	360	55	75
SJK4	400	70	95
SJK5	530	100	120
SJK6	700	125	160
SJK7	900	150	170

## Cable Jointing

### CELLPACK

#### Cellpack Straight Cable Joints



Selection chart for armoured cables.

Straight through joint selection chart

Cellpack - Clear Straight - Through Joint Type SJK.

**Conductors:** Copper to copper - compression splices or mechanical connectors suitable.  
Copper to aluminium/aluminium to aluminium - mechanical connectors only.

Part No.	Cable Size (mm <sup>2</sup> )	No. of cores	Min - Max cable dia. (mm)	Connectors Required (one connector required per core)	
				Compression	Mechanical
SJK1516	1.5	2	7-30	Included	-
SJK1516	1.5	3	7-30	Included	-
SJK1516	1.5	4	7-30	Included	-
SJK1516	2.5	2	7-30	Included	-
SJK1516	2.5	3	7-30	Included	-
SJK1516	2.5	4	7-30	Included	-
SJK1516	4	2	7-30	Included	-
SJK1516	4	3	7-30	Included	-
SJK1516	4	4	7-30	Included	-
SJK1516	6	2	7-30	Included	-
SJK1516	6	3	7-30	Included	-
SJK1516	6	4	7-30	Included	-
SJK1516	10	2	7-30	Included	-
SJK1516	10	3	7-30	Included	-
SJK1516	10	4	7-30	Included	-
SJK1516	16	2	7-30	Included	-
SJK1516	16	3	7-30	Included	-
SJK1516	16	4	7-30	Included	-

All joints are supplied with clear mould, resin pack, earth continuity, gloves, sealing tape.

Cable connectors included up to 16mm<sup>2</sup>.

Earth braid can be supplied separately.

## Cable Jointing

### CELLPACK

#### Cellpack Straight Cable Joints



Selection chart for armoured cables.

Straight through joint selection chart

Cellpack - Clear Straight - Through Joint Type SJK.

**Conductors:** Copper to copper - compression splices or mechanical connectors suitable.

Copper to aluminium/aluminium to aluminium - mechanical connectors only.

Part No.	Cable Size (mm <sup>2</sup> )	No. of cores	Min - Max cable dia. (mm)	Connectors Required (one connector required per core)	
				Compression	Mechanical
SJK1	1.5	2	7-30	-	Included
SJK1	1.5	3	7-30	-	Included
SJK1	1.5	4	7-30	-	Included
SJK1	2.5	2	7-30	-	Included
SJK1	2.5	3	7-30	-	Included
SJK1	2.5	4	7-30	-	Included
SJK1	4	2	7-30	-	Included
SJK1	4	3	7-30	-	Included
SJK1	4	4	7-30	Included	-
SJK1	6	2	7-30	Included	-
SJK1	6	3	7-30	Included	-
SJK1	6	4	7-30	Included	-
SJK2	10	2	14-30	Included	-
SJK2	10	3	14-30	Included	-
SJK2	10	4	14-30	Included	-

SJK1: 15 amp strip connectors

SJK2: 6, 10, 16mm<sup>2</sup> splices

All joints are supplied with clear mould, resin pack, earth continuity, gloves, sealing tape.

Cable connectors included up to 35mm<sup>2</sup>.

Earth braid can be supplied separately.

# Cable Jointing

## CELLPACK

### Cellpack Straight Cable Joints



Selection chart for armoured cables.

Straight through joint selection chart

Cellpack - Clear Straight - Through Joint Type SJK.

**Conductors:** Copper to copper - compression splices or mechanical connectors suitable.

Copper to aluminium/aluminium to aluminium - mechanical connectors only.

Part No.	Cable Size (mm <sup>2</sup> )	No. of cores	Min - Max cable dia. (mm)	Connectors Required (one connector required per core)	
				Compression	Mechanical
SJK2	16	2	14-30	Included	-
SJK2	16	3	14-30	Included	-
SJK2	16	4	14-30	Included	-
SJK2	25	2	14-30	Included	-
SJK3	25	3	20-37	Included	-
SJK4	25	4	25-42	-	(P1) Included
SJK3	35	2	20-37	Included	-
SJK4	35	3	25-42	-	(P1) Included
SJK4	35	4	25-42	-	(P1) Included
SJK3	50	2	20-37	Included	-
SJK4	50	3	25-42	50BS	-
SJK4	50	4	25-42	50BS	-

Copper to Aluminium/Aluminium to Aluminium

Part No.	Cable Size (mm <sup>2</sup> )	No. of cores	Min - Max cable dia. (mm)	Connectors Required (one connector required per core)	
				Compression	Mechanical
SJK5S	50	2	25-42	n/a	UM1
SJK5	50	3	33-55	n/a	UM1
SJK5	50	4	33-55	n/a	UM1

SJK2: 6, 10, 16mm<sup>2</sup> splices

SJK3: 16, 25, 35mm<sup>2</sup> splices

SJK4: P1 mechanical connectors

All joints are supplied with clear mould, resin pack, earth continuity, gloves, sealing tape.

Cable connectors included up to 35mm<sup>2</sup>.

Earth braid can be supplied separately.

## Cable Jointing

# CELLPACK

### Cellpack Straight Cable Joints



Straight through joint selection chart

Cellpack - Clear Straight - Through Joint Type SJK.

Selection chart for armoured cables.

**Conductors:** Copper to copper - compression splices or mechanical connectors suitable.

Copper to aluminium/aluminium to aluminium - mechanical connectors only.

Part No.	Cable Size (mm <sup>2</sup> )	No. of cores	Min - Max cable dia. (mm)	Connectors Required (one connector required per core)	
				Compression	Mechanical
SJK4	70	2	25-42	70BS	-
SJK5S	70	2	33-55	-	UM1
SJK5	70	3	33-55	70BS	UM1
SJK5	70	4	33-55	70BS	UM1
SJK4	95	2	25-42	95BS	UM1
SJK5	95	3	33-55	95BS	UM1
SJK5	95	4	33-55	95BS	-
SJK6S	95	4	45-74	-	UM1

#### Copper to Aluminium/Aluminium to Aluminium

Part No.	Cable Size (mm <sup>2</sup> )	No. of cores	Min - Max cable dia. (mm)	Connectors Required (one connector required per core)	
				Compression	Mechanical
SJK6S	95	4	45-74	n/a	UM1

All joints are supplied with clear mould, resin pack, earth continuity, gloves, sealing tape.

Cable connectors included up to 35mm<sup>2</sup>.

Earth braid can be supplied separately.

## CELLPACK

### Cellpack Straight Cable Joints



Straight through joint selection chart

Cellpack - Clear Straight - Through Joint Type SJK.

Selection chart for armoured cables.

**Conductors:** Copper to copper - compression splices or mechanical connectors suitable.

Copper to aluminium/aluminium to aluminium - mechanical connectors only.

Part No.	Cable Size (mm <sup>2</sup> )	No. of cores	Min - Max cable dia. (mm)	Connectors Required (one connector required per core) Compression or Mechanical	
SJK5	120	2	33-55	120BS	UM2
SJK5	120	3	33-55	120BS	UM2
SJK6	120	4	45-74	120BS	UM2
SJK5	150	2	33-55	150BS	UM2
SJK6	150	3	45-74	150BS	UM2
SJK6	150	4	45-74	150BS	UM2
SJK5	185	2	33-55	185BS	-
SJK6S	185	2	45-74	-	UM3
SJK6	185	3	45-74	185BS	UM3
SJK6	185	4	45-74	185BS	-
SJK7S	185	4	50-95	-	UM3
SJK6	240	2	45-74	240BS	UM3
SJK6	240	3	45-74	240BS	UM3
SJK7	240	4	50-95	240BS	UM3
SJK6	300	2	45-74	300BS	UM3
SJK7	300	3	50-95	300BS	UM3
SJK7	300	4	50-95	300BS	UM3
SJK7	400	2	50-95	400BS	MF1/4
SJK7	400	3	50-95	400BS	MF1/4
SJK7	400	4	50-95	400BS	MF1/4

All joints are supplied with clear mould, resin pack, earth continuity, gloves, sealing tape.

Cable connectors included up to 35mm<sup>2</sup>.

Earth braid can be supplied separately.



# Cable Jointing

## CELLPACK



For copper and aluminium cables.

### Multi-Core Cables Copper Conductors

For use with PVC Insulated - PVC Sheathed Armoured cables

Joint ref.	Nominal area of conductor (mm <sup>2</sup> )	No. of cores
SJK1	1.5	5
SJK2	1.5	7
SJK2	1.5	10
SJK3	1.5	12
SJK4	1.5	19
SJK4	1.5	22
SJK4	1.5	27
SJK4	1.5	30
SJK4	1.5	40
SJK5	1.5	48

Joint ref.	Nominal area of conductor (mm <sup>2</sup> )	No. of cores
SJK1	2.5	5
SJK2	2.5	7
SJK2	2.5	10
SJK3	2.5	12
SJK4	2.5	19
SJK4	2.5	22
SJK4	2.5	27
SJK4	2.5	30
SJK4	2.5	40
SJK5	2.5	48

### Multi-Pair Cables Copper Conductors

For use with PVC Insulated - PVC Sheathed Armoured cables

Joint ref.	Nominal area of conductor (mm <sup>2</sup> )	No. of pairs	Joint ref.	Nominal area of conductor (mm <sup>2</sup> )	No. of pairs	Joint ref.	Nominal area of conductor (mm <sup>2</sup> )	No. of pairs
SJK1	0.5	2	SJK1	0.9	2	SJK1	1.5	2
SJK2	0.5	5	SJK2	0.9	5	SJK2	1.5	5
SJK4	0.5	10	SJK4	0.9	10	SJK4	1.5	10
SJK4	0.5	15	SJK4	0.9	15	SJK4	1.5	15
SJK4	0.5	20	SJK4	0.9	20	SJK4	1.5	20
SJK5	0.5	25	SJK5	0.9	25	SJK5	1.5	25
SJK5	0.5	30	SJK5	0.9	30	SJK5	1.5	30
SJK5	0.5	40	SJK5	0.9	40	SJK5	1.5	40
SJK5	0.5	50	SJK5	0.9	50	SJK5	1.5	50
SJK6	0.5	100	SJK6	0.9	100	SJK6	1.5	100

Cable connectors for both Multi-core and Multi-pair cables supplied only on request. All joints supplied with clear mould, resin pack, earth continuity, gloves and sealing tape.

# Cable Jointing

## CELLPACK

### Cellpack 'Y' or Branch Cable Joints



**Voltage Level:** 1.2 kV

**Application:** Universally suitable to connect low voltage plastic-insulated cables or connectors insulated with PVC, PE, VPE, and EPR. (e.g N(A)YY, NYM, TT) With or without concentric conductor. Suitable for both copper and aluminium conductors.

**Application Ranges:** Indoor, outdoor, underground, water (e.g submersible pumps), cable trays.

- Features:**
- High electrical insulation values
  - Watertight both longitudinally and transversely
  - High mechanical strength
  - Good resistance against UV radiation, alkaline earths and chemical agents
  - Standard resin storable up to 40 months in the aluminium bag
  - Halogen-free polyurethane cast resin, containing the correct volume ready for mixing within a handy two-chamber mixing bag. No need for skin contact
  - Low hardening temperature, fast hardening with no toxic emission during the mixing and casting
  - High quality, transparent, shockproof polycarbonate moulds, compact size
  - Visible splice position before casting
  - Large insertion opening for easy casting
  - Extremely simple and fast fitting - saves time and costs
  - Immediately operational

**Tests and Approvals:** DIN VDE 0278 Part 1 and 3, DIN VDE 0278 PART 393, EN 50393 as well as CENELEC HD623 (VDE 0278, PART 623)

### Mould Dimensions

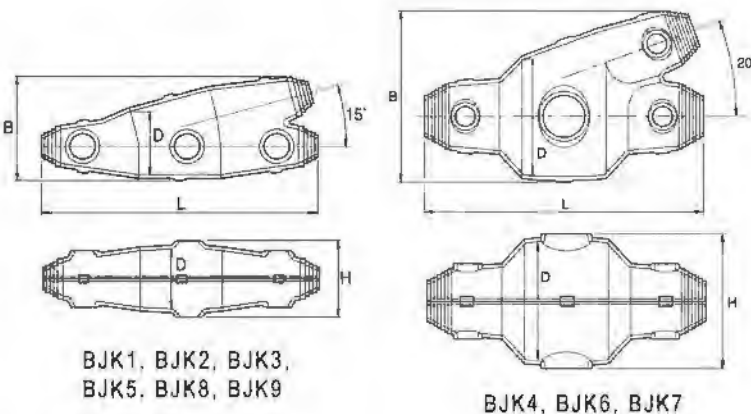

Part No.	L (mm)	B (mm)	D (mm)	H (mm)
BJK1	185	80	45	55
BJK2	240	110	60	70
BJK3	285	120	65	75
BJK4	240	145	100	110
BJK5	300	150	110	120
BJK6	285	170	110	120
BJK7	335	193	120	130
BJK8	382	220	140	150
BJK9	570	275	180	190

## Cable Jointing

### CELLPACK

#### Cellpack 'Y' or Branch Cable Joints



Copper to copper (cut mains).

Copper to aluminium - unless specified separately as detailed below.

Part No.	Mains Cable		Branch Cable		Min - Max cable dia. (mm)		Connectors
	mm <sup>2</sup>	Cores	mm <sup>2</sup>	Cores	Mains	Branch	
BJK1	1.5	2	1.5	2	8-17	8-17	Included
BJK1	1.5	3	1.5	3	8-17	8-17	Included
BJK1	1.5	4	1.5	4	8-17	8-17	Included
BJK1	2.5	2	2.5	2	8-17	8-17	Included
BJK1	2.5	3	2.5	3	8-17	8-17	Included
BJK1	2.5	4	2.5	4	8-17	8-17	Included
BJK2	4.0	2	4.0	2	9-22	8-17	Included
BJK2	4.0	3	4.0	3	9-22	8-17	Included
BJK2	4.0	4	4.0	4	9-22	8-17	Included
BJK2	6.0	2	6.0	2	9-22	8-17	Included
BJK2	6.0	3	4.0	3	9-22	8-17	Included
BJK2	6.0	4	2.5	4	9-22	8-17	Included
BJK3	10	2	10	2	22-39	18-35	Included
BJK3	10	3	10	3	22-39	18-35	Included
BJK3	10	4	10	4	22-39	18-35	Included

One connector required per core.

All joints are supplied with clear mould, resin pack, earth continuity, gloves, sealing tape.

Cable connectors included up to 35mm<sup>2</sup>.

Earth braid can be supplied separately.

## CELLPACK

### Cellpack 'Y' or Branch Cable Joints



Copper to copper (cut mains).

Copper to aluminium - unless specified separately as detailed below.

Part No.	Mains Cable		Branch Cable		Min - Max cable dia. (mm)		Connectors (Not included unless indicated)
	mm <sup>2</sup>	Cores	mm <sup>2</sup>	Cores	Mains	Branch	
BJK3	16	2	16	2	22-39	18-35	Included
BJK3	16	3	16	3	22-39	18-35	Included
BJK3	16	4	10	4	22-39	18-35	Included
BJK4	25	2	25	2	25-42	21-37	Included
BJK4	25	3	25	3	25-42	21-37	Included
BJK4	25	4	25	4	25-42	21-37	Included
BJK4	35	2	25	2	25-42	21-37	Included
BJK4	35	3	35	3	25-42	21-37	Included
BJK4	35	4	35	4	30-54	20-38	Included
BJK4	50	2	50	2	25-42	21-37	LT50
BJK4	50	3	50	3	25-42	21-37	LT50
BJK5	50	4	50	4	30-54	20-38	LT50

Copper to Aluminium/Aluminium to Aluminium Cores

Part No.	Mains Cable		Branch Cable		Min - Max cable dia. (mm)		Connectors (Not included)
	mm <sup>2</sup>	Cores	mm <sup>2</sup>	Cores	Mains	Branch	
BJK6AS	50	2	50	2	29-53	21-37	WM1
BJK7AS	50	3	50	3	32-56	25-42	WM1
BJK8AS	50	4	50	4	35-62	29-52	WM1

One connector required per core.

All joints are supplied with clear mould, resin pack, earth continuity, gloves, sealing tape.

Cable connectors included up to 35mm<sup>2</sup>.

Earth braid can be supplied separately.

## Cable Jointing

# CELLPACK

### Cellpack 'Y' or Branch Cable Joints



Copper to copper (cut mains).

Copper to aluminium - unless specified separately as detailed below.

Part No.	Mains Cable		Branch Cable		Min - Max cable dia. (mm)		Connectors (Not included)
	mm <sup>2</sup>	Cores	mm <sup>2</sup>	Cores	Mains	Branch	
<b>BJK5</b>	70	2	70	2	30-54	20-38	LT70
<b>BJK7S</b>	70	3	70	3	32-56	25-42	LT70
<b>BJK7S</b>	70	4	35	4	32-56	25-42	LT70
<b>BJK8</b>	70	4	70	4	35-62	29-52	LT70
<b>BJK6</b>	95	2	95	2	29-53	21-37	LT95
<b>BJK7</b>	95	3	95	3	32-56	25-42	LT95
<b>BJK8</b>	95	4	70	4	32-56	25-42	LT95
<b>BJK8S</b>	95	4	95	4	35-62	29-52	LT95

Copper to Aluminium/Aluminium to Aluminium Cores

Part No.	Mains Cable		Branch Cable		Min - Max cable dia. (mm)		Connectors (Not included)
	mm <sup>2</sup>	Cores	mm <sup>2</sup>	Cores	Mains	Branch	
<b>BJK6A</b>	70	2	70	2	29-53	21-37	WM1
<b>BJK8A</b>	70	3	70	3	35-62	29-52	WM1
<b>BJK8A</b>	70	4	70	4	35-62	29-52	WM1
<b>BJK7A</b>	95	2	95	2	32-56	25-42	WM1
<b>BJK9AS</b>	95	3	95	3	35-62	29-52	WM1
<b>BJK9AS</b>	95	4	95	4	35-62	29-52	WM1

One connector required per core.

All joints are supplied with clear mould, resin pack, earth continuity, gloves, sealing tape.

Cable connectors included up to 35mm<sup>2</sup>.  
Earth braid can be supplied separately.

## Cable Jointing

### CELLPACK

#### Cellpack 'Y' or Branch Cable Joints



Copper to copper (cut mains).

Copper to aluminium - unless specified separately as detailed below.

Part No.	Mains Cable		Branch Cable		Min - Max cable dia. (mm)		Connectors (Not included)
	mm <sup>2</sup>	Cores	mm <sup>2</sup>	Cores	Mains	Branch	
<b>BJK8</b>	120	2	120	2	35-62	29-52	WM2
<b>BJK9S</b>	120	3	120	3	45-90	35-80	WM2
<b>BJK9S</b>	120	4	95	4	45-90	35-80	WM2
<b>BJK9</b>	120	4	120	4	45-90	35-80	WM2
<b>BJK8S</b>	150	2	70	2	35-62	29-52	WM2
<b>BJK9</b>	150	3	150	3	45-90	35-80	WM2
<b>BJK9</b>	150	4	150	4	45-90	35-80	WM2
<b>BJK8</b>	185	2	185	2	35-62	29-52	WM2
<b>BJK9</b>	185	3	185	3	45-90	35-80	WM2
<b>BJK9</b>	185	4	185	4	45-90	35-80	WM2

One connector required per core.

Larger sizes available - P.O.A

All joints are supplied with clear mould, resin pack, earth continuity, gloves, sealing tape.

Cable connectors included up to 35mm<sup>2</sup>.

Earth braid can be supplied separately.

## Cable Jointing

# CELLPACK

## Cellpack 'T' Cable Joints



**Voltage Level:** 1.2 kV

**Application:** Universally suitable to connect low voltage plastic-insulated cables or connectors insulated with PVC, PE, VPE, and EPR. (e.g N(A)YY, NYM, TT) With or without concentric conductor. Suitable for both copper and aluminium conductors.

**Application Ranges:** Indoor, outdoor, underground, water (e.g submersible pumps), cable trays.

- Features:**
- High electrical insulation values
  - Watertight both longitudinally and transversely
  - High mechanical strength
  - Good resistance against UV radiation, alkaline earths and chemical agents
  - Standard resin storable up to 40 months in the aluminium bag
  - Halogen-free polyurethanic cast resin, containing the correct volume ready for mixing within a handy two-chamber mixing bag. No need for skin contact
  - Low hardening temperature, fast hardening with no toxic emission during the mixing and casting
  - High quality, transparent, shockproof polycarbonate moulds, compact size
  - Visible splice position before casting
  - Large insertion opening for easy casting
  - Extremely simple and fast fitting - saves time and costs
  - Immediately operational

**Tests and Approvals:** DIN VDE 0278 Part 1 and 3, DIN VDE 0278 PART 393, EN 50393 as well as CENELEC HD623 (VDE 0278, PART 623)

### Mould Dimensions

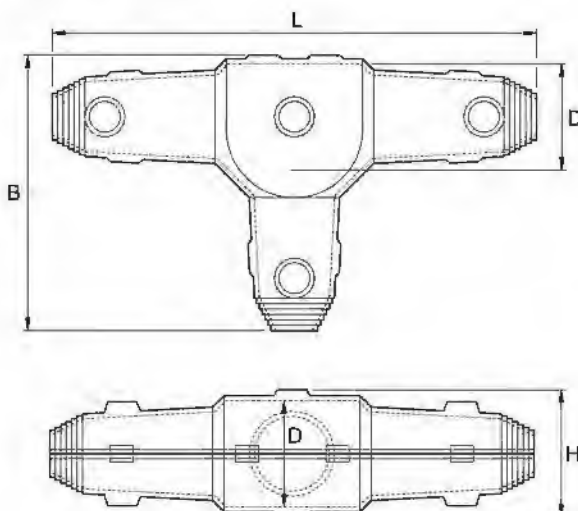

Part No.	L (mm)	B (mm)	D (mm)	H (mm)
T1-EK	240	138	50	60
T2-EK	267	154	60	70
T3-EK	354	212	90	100
T4-EK	432	262	110	125
T5-EK	550	290	130	155

## Cable Jointing

# CELLPACK

## Cellpack 'T' Cable Joints



Suitable for copper to copper, copper to aluminium, aluminium to aluminium.

Part No.	Mains Cable		Branch Cable		Min - Max cable dia. (mm)		Connectors
	mm <sup>2</sup>	Cores	mm <sup>2</sup>	Cores	Mains	Branch	
T1-EK	1.5	2	1.5	2	22	22	P1 Included
T1-EK	1.5	3	1.5	3	22	22	P1 Included
T1-EK	1.5	4	1.5	4	22	22	P1 Included
T1-EK	2.5	2	2.5	2	22	22	P1 Included
T1-EK	2.5	3	2.5	3	22	22	P1 Included
T1-EK	2.5	4	2.5	4	22	22	P1 Included
T1-EK	4.0	2	4.0	2	22	22	P1 Included
T1-EK	4.0	3	4.0	3	22	22	P1 Included
T1-EK	4.0	4	4.0	4	22	22	P1 Included
T1-EK	6.0	2	6.0	2	22	22	P1 Included
T1-EK	6.0	3	6.0	3	22	22	P1 Included
T2-EK	6.0	4	6.0	4	30	30	P1 Included
T1-EK	10	2	10	2	22	22	P1 Included
T2-EK	10	3	10	3	30	30	P1 Included
T2-EK	10	4	10	4	30	30	P1 Included

One connector required per core.

All joints are supplied with clear mould, resin pack, earth continuity, gloves, sealing tape.

Cable connectors included up to 35mm<sup>2</sup>.  
Earth braid can be supplied separately.



## Cable Jointing

# CELLPACK

### Cellpack 'T' Cable Joints



Suitable for copper to copper, copper to aluminium, aluminium to aluminium.

Part No.	Mains Cable mm <sup>2</sup>	Cable Cores	Branch Cable mm <sup>2</sup>	Cable Cores	Min - Max cable dia. (mm)		Connectors (Not included unless indicated)
					Mains	Branch	
T2-EK	16	2	16	2	30	30	P1 Included
T2-EK	16	3	16	3	30	30	P1 Included
T3-EK	16	4	16	4	37	37	P1 Included
T3-EK	25	2	25	2	37	37	P1 Included
T3-EK	25	3	25	3	37	37	P1 Included
T3-EK	25	4	25	4	37	37	P1 Included
T3-EK	35	2	35	2	37	37	P1 Included
T3-EK	35	3	35	3	37	37	P1 Included
T4-EK	35	4	35	4	52	52	P1 Included
T3-EK	50	2	50	2	37	37	LT70
T3-EK	50	3	50	3	37	37	LT70
T3-EK	50	4	50	4	37	37	LT70
T3-EK	70	2	70	2	37	37	LT70
T3-EK	70	3	70	3	37	37	LT70
T4-EK	70	4	70	4	52	52	LT70
T4-EK	95	2	95	2	52	52	LT95
T4-EK	95	3	95	3	52	52	LT95
T5-EK	95	4	95	4	62	55	LT95
T5-EK	120	2	120	2	62	55	LT120
T5-EK	120	3	120	3	62	55	LT120
T5-EK	120	4	120	4	62	55	LT120

One connector required per core.

All joints are supplied with clear mould, resin pack, earth continuity, gloves, sealing tape.

Cable connectors included up to 35mm<sup>2</sup>.

Earth braid can be supplied separately.

## Cable Jointing

### CELLPACK

#### Cellpack 'YCP' Cable Joints



For cables up to 1.2 kV

#### Application:

Suitable to branch-off single-core cables or wires, e.g wires for cathodic corrosion protection from chemical and electrochemical reactions below surface and water. Pipes, warehouse containers, electric supply lines and other metal constructions are effectively protected against passive corrosion (plastic casings, mastic-glass fibre casings).

- Features:**
- High electrical insulation values
  - Watertight both longitudinally and transversely
  - High mechanical strength
  - Good resistance against UV-radiation, alkaline earths and chemical agents
  - Standard resin storable for up to 40 months
  - High quality polycarbonate moulds
  - Visible splice position before casting
  - Extremely simple and fast fitting - saving time and cost
  - Immediately operational

Part No.	L (mm)	B (mm)	D (mm)	H (mm)
YCP	135	48	44	75

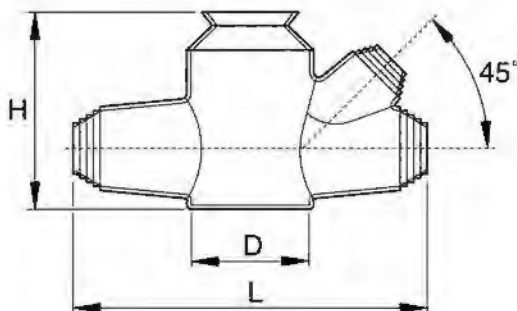

All joints are supplied with clear mould, resin pack, earth continuity, gloves, sealing tape.

Earth braid can be supplied separately.

## Cable Jointing

### CELLPACK



### Cast Resin - 2 Component Polyurethane (PUR) Resin

- Suitable for:**
- Low-voltage plastic insulated and paper insulated cables rated up to 1kV
  - Telecommunications and signal plastic insulated and paper insulated cables
  - Suitable for mechanical protection and water-sealing on medium voltage cables

- Features:**
- Halogen-free unfilled two-component polyurethane cast resin
  - Developed especially for cable joints
  - Excellent flow properties
  - No cracks during electrical and mechanical stress
  - Good adherence to all cable materials
  - Soft-elastic character ensures equalization of mechanical stresses
  - Low hardening temperature
  - Fast hardening
  - Excellent hydrolytical resistance
  - No toxic emission during mixing and casting
  - Packed in practical and easy-to-use two chamber bags

**Tests:**

- Governmental Material Test Laboratory Darmstadt: DIN VDE 0291
- KEMA Netherland: Report on the MAK value, which lies well below the maximum value of 0.01 ppm, allowed by law

**Storage Conditions:**

- At ambient temperatures between +15°C and +35°C
- 40 months in the aluminium bag

Part No.	Volume (ml)
EG180	180
EG286	286
EG370	370
EG464	464
EG650	650
EG810	810
EG1150	1150
EG1500	1500
EG1850	1850
EG2000	2000

Full specification available on request.  
Other volumes, and tins, available on request.

### Cable Joint Kits - Resin/Hardener Sizes

SWA Kit	Resin/Hardener Pack	Quantity
SJK1	EG180 (180ml)	1
SJK2	EG370 (370ml)	1
SJK3	EG650 (650ml)	1
SJK4	EG1150 (1150ml)	1
SJK5	EG1150 (1150ml)	1
	EG2000 (2000ml)	1
SJK6	EG1500 (1500ml)	3
	EG2000 (2000ml)	1

SWA Kit	Resin/Hardener Pack	Quantity
BJK1	EG286 (286ml)	1
BJK2	EG464 (464ml)	1
BJK3	EG810 (810ml)	1
BJK4	EG1150 (1150ml)	1
BJK5	EG2000 (2000ml)	1
BJK6	EG1150 (1150ml)	1
BJK7	EG1150 (1150ml)	2
BJK8	EG1850 (1850ml)	2
BJK9	EG1850 (1850ml)	6

# CELLPACK

## Universal Termination Box - AZ-KG Box

With the new Universal Box, whether you splice or branch off, an IP68 level is perfectly possible within minutes, using traditional and well proven technologies. The final system guarantees an absolute waterproof solution, excluding all condensation risks.

### Description:

- Universal applications
- Quick mounting
- Complete with connectors for cables 1.5 - 2.5mm<sup>2</sup> (230/400V)
- Long lasting even in very humid environments
- UV resistant
- Highly flexible due to removable resin
- Environmentally friendly
- L85mm x W85mm x D43mm
- Colour: Grey

### Approvals:

- IP54 - Box only
- IP68 - with the addition of the resin



AZ-KG Box



Additional resin available seperately:  
**KG286** (286ml)

# Cable Jointing

## Heatshrink Cable Joint Kits

For 1Kv  
PVC or XLPE steel wired armoured cable.

Quick and easy to use, immediate backfill, immediate power-up, slim profile - ideal for jointing vertical cables with the advantage of being re-enterable.

Introducing a comprehensive range of SWA straight through heatshrink cable joints for polymeric insulated armoured multi-core cables up to 1Kv (1.5mm<sup>2</sup> - 300mm<sup>2</sup>). SWA heatshrink joint kits have been tried and proved over a number of years by Cellpack Germany who are major manufacturers of high quality adhesive lined heatshrink tubing which is the most important component of these kits.

SWA kits have been manufactured to meet national and international standards such as VDE0278, BS6910, DoT, electricity board standards etc.

Part No. 1Kv	Cable size (mm <sup>2</sup> )	No. of cores
SMH1	1.5-4	4
SMH2	6-16	4
SMH3	25-50	4
SMH4	70-150	4
SMH5	185-300	4



## Underwater Heatshrink Kits

Part No.	Description
UJK1	For flexible underwater cable up to 2.5mm <sup>2</sup> - 4 core
UJK2	For flexible underwater cable up to 6mm <sup>2</sup> - 4 core
UJK3	For flexible underwater cable 1.5mm <sup>2</sup> - 4mm <sup>2</sup> - 4 core
UJK4	For flexible underwater cable 6mm <sup>2</sup> - 10mm <sup>2</sup> - 4 core
UJK5	For flexible underwater cable 16mm <sup>2</sup> - 25mm <sup>2</sup> - 4 core



See page 105 for technical detail on SRH2 sleeving.

# Mechanical Connectors

## Sicon Shear-Bolt Connectors

- Wide application range for each connector
- Can be used on copper or aluminium conductors up to 36kV
- Manufactured from aluminium alloy
- Reduces installation time, no need for crimp tools



## Shear Bolt Splices Connectors

Part No.	Dimensions mm			No. of Screws	Round (mm <sup>2</sup> )	Round and Compacted (mm <sup>2</sup> )	Solid Alum. & Copper Cond. (mm <sup>2</sup> )	Hexagon key
	D $\phi$ / d $\phi$ / L							
SBS10-95	24	13	65	2	10-95	10-95	10-70	4mm-3/16"
SBS50-240	33	20	126	4	50-185	50-240	50-185	6mm-1/4"
SBS95-300	38	24	140	4	95-300	95-300	95-240	8mm-5/16"

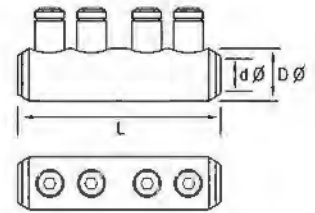

## Type MF Cable Connectors

Mechanical connector for straight through joints up to 11Kv. For stranded 2 and 4 core cables. Ideal for jointing cables where naked flame is prohibited i.e. mining or petro-chemical industry. Supplied with fitting instructions. Contact SWA for technical data.

Part No.	Core CSA (mm <sup>2</sup> )	
	Minimum	Maximum
MF1/1	50	95
MF1/2	95	185
MF1/3	185	300
MF1/4	400	500
MF1/5	150	300



# Mechanical Connectors

## Type UM Cable Connectors

Designed for straight through mains to accept 3 or 4 core sector shaped stranded conductors incorporating the shear head screw principle for reliable connection. Supplied with fitting instructions. Contact SWA for technical data.



Table (a)

Part No.	Core CSA (mm <sup>2</sup> )	
	Minimum	Maximum
UM1	35	95
UM2	95	150
UM3	185	300

### Secondary Applications

#### (a) Solid Aluminium Conductors

These connectors can accommodate sector shaped solid aluminium conductors within the ranges specified below. For these Connections the pressure-pad is normally removed.

#### (b) Circular Conductors

These connectors are also suitable for stranded circular conductors to BS6360 (copper) and BS6791 (aluminium) in the following ranges:-

Table (b)

Part No.	Core CSA (mm <sup>2</sup> )			
	(a) Solid Aluminium		(b) Circular Conductors	
	Min.	Max.	Min.	Max.
UM1	70	95	35	95
UM2	95	150	95	120
UM3	185	300	120	300

## Type WM Cable Connectors

For copper and aluminium cables

Mains branch connectors to accept 3 and 4 core sector shaped stranded conductors incorporating the shear head screw principle for reliable connection. Supplied with fitting instructions. Contact SWA for technical data.



### Stranded Sector Shaped Conductors

Part No.	Core CSA (mm <sup>2</sup> )			
	Mains		Branch	
	Min.	Max.	Min.	Max.
WM1	16*	95	16*	95
WM2	50	185	50	185
WM3	120	300	120	300

### Secondary Applications

These connectors can accept stranded circular conductors to BS6360 (copper) and BS6791 (aluminium) in the main and/or branch sides of the connector in the following ranges:-

### Stranded Circular Conductors

Part No.	Core CSA (mm <sup>2</sup> )			
	Mains		Branch	
	Min.	Max.	Min.	Max.
WM1	16	70	16	70
WM2	50	150	50	150
WM3	120	240	120	240

## Mechanical Connectors

### Type P Cable Connectors

For copper and aluminium cables

#### P1 connectors

To suit all types of service cable from 2.5mm<sup>2</sup> to 35mm<sup>2</sup> CSA for branch and straight through connectors. Supplied complete with brass gauze.

P1 Connector with gauze



### Type US Cable Connectors

For copper and aluminium cables

Ideal for connecting stranded circular/sector shaped services to 3 or 4 core stranded sector shaped mains conductors. Supplied with fitting instructions. Contact SWA for technical data.

Part No.	Mains		Service Max.
	Min.	Max.	
US1	50	95	35
US2	120	150	35
US3	185	300	35



### Type MF Cable Connectors

Designed for straight connections on stranded or solid service cables, made in brass to be suitable for jointing copper/aluminium and sector/circular conductors. Contact SWA for technical data.

Part No.	Type	Core CSA (mm <sup>2</sup> )	
		Minimum	Maximum
MF4/1	Straight through	6*	16
MF4/2	Straight through	16	50
MF4/3	Moisture blocked	6*	16
MF4/4	Moisture blocked	16	50

MF4/1



\* Conductors below 6mm<sup>2</sup> should be doubled, and if necessary, doubled again to achieve a satisfactory cross sectional area connection.



# Mechanical Connectors

## Line Tops

**Material:** Brass BS2874 - CZ112

**Finish:** Nickel plated

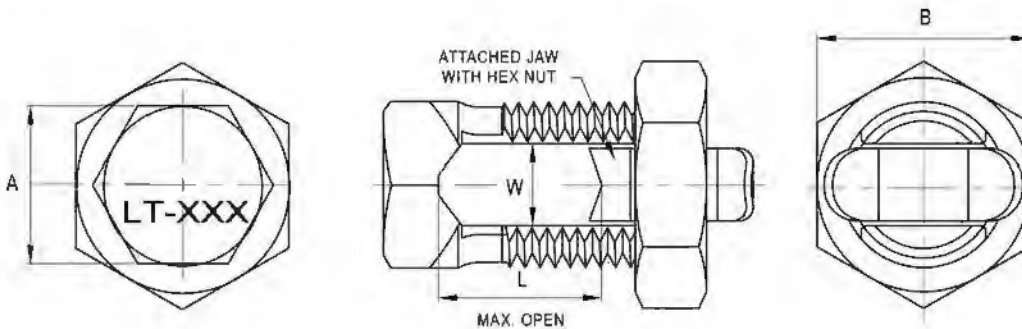

Part No.	Conductor Range		Dimensions mm			
	Min (mm <sup>2</sup> )	Max (mm <sup>2</sup> )	Body A/F A	Nut A/F B	Width W	Length L
LT610	6	10	10.0	12.6	3.7	7.4
LT10	10	16	12.0	16.0	5.5	8.5
LT16	16	25	14.0	18.0	6.9	9.0
LT25	25	35	15.0	20.0	8.4	11.0
LT35	35	50	18.0	24.0	9.7	12.0
LT50	50	70	20.0	25.0	11.2	14.0
LT70	70	95	22.0	28.0	13.6	18.0
LT95	95	120	25.0	33.0	16.0	24.0
LT120	120	150	28.0	36.0	19.0	30.0

## Cable Jointing Accessories

### Underground Marking Tape

Damaging a buried utility line is an expensive accident which could have serious consequences. Installed 300mm above the buried pipe or cable, these tapes provide an early warning to contractors.

Part No.	Length (m)	Width (mm)	Colour	Tape description
UMT-EL	365	150	Yellow	Electrical Cable Below
UMT-STL	365	150	Yellow	Street Lighting Cable Below
UMT-TEL	365	150	Green	Telephone Cable Below

Other types and languages available to order.



### Cable Protection Tiles

Heavy duty, yet lightweight recycled polyethylene cable covers, incorporating a colour printed polyethylene warning tape laminated to the top surface. The environmentally friendly cable tiles should be laid over power cables which require additional protection.

- High impact resistance – manufactured to BS 2484
- Free from PVC – acid and alkali resistant
- Rot resistant
- Lightweight, meaning low transportation and installation costs
- All cable covers are pre-drilled and supplied with a jointing peg for easy installation. The linear length when joined is approximately 960mm
- Wording 'CAUTION ELECTRIC CABLE BELOW'

Other texts can be manufactured to order.

Part No.	Length (mm)	Width (mm)	Thickness (mm)
UMCT150	1000	150	6



Barrier and Hazard Warning Tape also available. See Tapes and Sealants page 193.

# CABLE HANDLING



**Cable Drum Jacks..... 146**



**Cable Rollers..... 146**

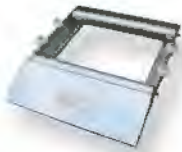

**Cable Drum Rotators..... 147**



**Cable Drum Dispenser..... 147**



**Cable Socks..... 148**

# CABLE HANDLING

## Cable Handling

SWA screw type cable drum jacks are manufactured from fabricated steel. They are fully approved and test certificates are available upon request.

The spindles, supplied with the jacks, are manufactured from high quality steel bar.

Locking collars can be provided on request.

All cable jacks are safety tested to the 'Lifting Operations & Lifting Equipment (LOLER) regulations 1998'.

### Screw Mechanical Cable Drum Jack Set

(2 jack legs and 1 spindle)

Part No.	Capacity/pair (tonne)	Min. Drum Diameter (mm)	Max. Drum Diameter (mm)
CDJ-3	3	1060	1600
CDJ-6	6	1360	1900

Also available to hire, see page 151



### Replacement Spindles

Part No.	Diameter (mm)	Length (mm)	Weight (kg)	Supplied with
DS-6	50	1800	28	CDJ-3/CDJ-6



### Hydraulic Cable Drum Jacks

Part No.	Capacity/pair (tonne SWL)	Min. Drum Diameter (mm)	Max. Drum Diameter (mm)
CDJH-3	3	800	2500
CDJH-6	6	880	3000

### Cable Rollers

Ideal for handling cable, these steel zinc plated rollers are suitable for cable up to 125mm diameter.

Part No.	Base size (mm)	Weight (Kg)
TRP125	520 x 225	2.5

Also available to hire, see page 151

Other types and sizes available on request



# Cable Handling

## Cable Drum Rotators

Ideal for steel wire armoured heavy duty cables

### CDR 2

**Type:** All steel welded

**Finish:** Zinc plated

**Rollers:** 1 Fixed, 1 Adjustable and fitted sealed ball bearing



### CDR 3

**Rollers:** 2 Adjustable, Fitted sealed ball bearing

**Finish:** Zinc plated



Part No.	Drum Weight Max. (kg)	Drum Dia. Max. (mm)	Drum Dia. Min. (mm)	Drum Width	Length (mm)	Width (mm)	Height (mm)	Weight (kg)
CDR 2	1500	2400	300	Adjustable	1000	260	120	54/pair
CDR 3	140	520	120	n/a	650	680	110	11.5

## Cable Dispenser

- Heavy duty
- Time and cost effective
- Easily folds away for storage
- Max. carry weight: 50kg
- Dimension (open): L 760mm  
H 340mm  
W 340mm
- Distance between arms: 610mm



Part No.	Unit Dimensions-closed(mm)			Unit Dimensions-open(mm)			Max. Carry Weight (kg)	Distance between arms (mm)	Weight of Unit (kg)
	Width	Height	Length	Width	Height	Length			
CDD1	40	380	760	340	340	760	50	610	2.8

# Cable Handling

## Cable Socks

- An efficient method of supporting or pulling cables
- Manufactured from high tensile galvanised steel wire, our range of cable socks are available with single or double-eye for attaching to the pulling rope
- Lace-up cable socks are also available for fitting at midpoint along the cable length
- The standard range covers all cables from 6mm to 115mm overall diameter



CS Type



CSD Type



CSDS Type

Part Number			Cable Dia. (mm)	Lattice Length (mm)	Overall Length (mm)	Actual Break (tonnes)
Single eye	Double eye	Double eye split				
CS6-13	CSD6-13	CSDS6-13	6 - 13	230	305	0.75
CS13-19	CSD13-19	CSDS13-19 <sup>o</sup>	13 - 19	355	430	1.00
CS19-25	CSD19-25	CSDS19-25	19 - 25	405	510	2.50
CS25-38	CSD25-38	CSDS25-38	25 - 38	455	610	3.50
CS38-50	CSD38-50	CSDS38-50	38 - 50	535	735	5.00
CS50-63	CSD50-63	CSDS50-63	50 - 63	610	865	5.00
CS63-89	CSD63-89	CSDS63-89	63 - 89	685	990	6.00
CS89-115	CSD89-115	CSDS89-115	89 - 115	685	990	7.00

Stainless steel versions available on request

# TOOLING

# TOOLING



*Tool Hire*..... 151



**UNIOR** Tools..... 152-153



**pressmaster**® *Mobile Crimp Tool*..... 154-157



**pressmaster**® *Stripping Tools*..... 158-159



*Crimp Tools For Pre-insulated Terminals*..... 160-161



*Service Pliers*..... 161



*Crimp Tools For Un-insulated Terminals*..... 161-162



*Crimp Tools For Bootlace Ferrules*..... 163-164



*Large Hand Crimp Tools*..... 165



*Hydraulic Crimp Tools*..... 166



*Hydraulic Crimp Heads*..... 167

# TOOLING



**Hydraulic Pumps..... 167**



**Battery Operated Crimp Tools and Cutters..... 168-169**



**Electrical Crimping Unit..... 170**



**Pneumatic Crimp Tool..... 170**



**Cable Cutters..... 171-172**



**Hydraulic Cable Cutters..... 172**



**Wire Strippers, Mini Trunking Tools, Conduit Cutters..... 173**



**Impact and Punch Down Tools..... 174**



**Modular Crimp Tool Kit..... 174**



**Cable Tie Tensioning Tools..... 175**



**Hot Air Guns..... 175**



# Tool Hire Solutions

Our Philosophy is simple!  
Make hiring equipment easy and more convenient

All tools offered for hire are regularly serviced and are fully checked, tested and calibrated prior to despatch.

SWA also offer a tool repair, calibration and servicing facility.

Tool hire and repair service registered to  
BS EN ISO 9001:2008 standard



## It's really easy to hire from SWA

All items are usually available for next day delivery (Monday - Friday)  
anywhere in the UK.

(a.m, service available at extra cost)

Our hire periods vary from 2 to 7 days (or longer on request)  
just call our hire team for more information.

All cable jacks are safety tested to the 'Lifting Operations & Lifting Equipment  
(LOLER) regulations 1998'.

### How does it work?

- Branches call our tool hire helpline  
(Tel: 01453 844 333)
- Tell us what you need & for how long  
and to whom you would like it delivered
- Provide SWA with an order number
- SWA will deliver directly to your customer  
and arrange collection back to SWA on  
completion of the tool hire
- SWA will then raise an invoice to cover the  
total hire charge



Our experienced team are on call to help and  
advise you with everything from ordering,  
delivery, collection and health and safety  
requirements.

# UNIOR® HAND TOOLS

## EXCLUSIVE TO SWA\*

\* Exclusive UK distributor

**SWA is the UK's exclusive distributor of Unior VDE Tools to the electrical industry.**

Complying with European and Global quality standards, Unior VDE Tools offer the following advantages to the professional electrician:

- + Modern and functional
- + Ergonomic design
- + Comprehensive range
- + Value for money
- + Lifetime guarantee
- + Extensive local stocks
- + Full range of 1000v VDE insulated hand tools
- + Each tool individually tested
- + Quality you can trust from your preferred supplier
- + Use with confidence

European manufacture and quality control means tools that can be trusted 100%, all day, every day.



**Ask for a copy of the SWA Unior Hand Tool catalogue**

**1000V**  
IEC 60900:2004

Hand tools for live working  
up to 1000 V A.C



Sign of the institution  
certifying the tools  
(VERBAND DEUTSCHER  
ELEKTROTECHNIKER).

A sign indicating that the tools  
are in accordance with the signed  
standard (DIN), which prescribes  
the basic demands for tools  
(dimension, hardness, mechanical  
testing etc).

Only tools with the recognisable VDE certification sign are trusted insulated tools.

## VDE BI Line

- Material: special tool steel
- Entirely hardened and tempered
- Cutting edges induction hardened
- Head polished
- Surface finish: chrome plated to standard EN12540
- Heavy duty double-component handles
- Jet stamp UNIOR



## Screwdrivers

- Blade: chrome-vanadium-molybdenum steel, entirely hardened and tempered
- Blacken tip
- Handle: ergonomic shape
- Three component material
- Hanging hole



Scan to  
view demo

Free Tool Merchandiser  
available with stock order



# pressmaster®

## Mobile Crimp Tool

The ideal choice for electrical installers.

- One tool frame
- Genuine snap-in & snap-out facilities
- No additional tools needed
- Most standard connectors are covered in the range
- Save the expense of multiple tools



Practical and easy to use.



Quick fit/release of crimp dies.



User friendly design.



Crimp dies held together.

**Mobile Crimp Tool**

Crimp tool & dies	Connector	Wire range	Part No.
-------------------	-----------	------------	----------



**4300-3149**

Mobile Crimp Tool frame - designed for engineers who carry their tools to work. The tool has a full cycle ratchet action and features Snap-in/Snap-out dies (listed below) that are pinned permanently together to prevent loss. Each die comes in a plastic holder that clips together to form a die holder for multiple dies.



0.1 - 0.4mm<sup>2</sup>  
and 4 - 6mm<sup>2</sup>

**4300-3128**

Die Set with 2 cavities, one for Mini yellow (0.1 - 0.4mm<sup>2</sup>) and standard yellow terminals 4 - 6mm<sup>2</sup>



0.5mm<sup>2</sup> to  
2.5mm<sup>2</sup>

**4300-3129**

Die Set with 2 cavities, one for Red pre-insulated terminals 0.5mm<sup>2</sup> to 2.5mm<sup>2</sup> and Blue pre-insulated terminals 1.5mm<sup>2</sup> - 2.5mm<sup>2</sup>



0.35mm<sup>2</sup> to  
2.5mm<sup>2</sup>

**4300-3137**

Die Set with 3 cavities for un-insulated terminals, 0.35mm<sup>2</sup> to 0.75mm<sup>2</sup>, 1mm<sup>2</sup> to 1.5mm<sup>2</sup> and 2.5mm<sup>2</sup>

Die Set with 3 cavities for un-insulated terminals, 4mm<sup>2</sup>, 6mm<sup>2</sup> and 10mm<sup>2</sup>

4mm<sup>2</sup> to  
10mm<sup>2</sup>

**4300-3139**

Mobile Crimp Tool

Crimp tool & dies	Connector	Wire range	Part No.
-------------------	-----------	------------	----------

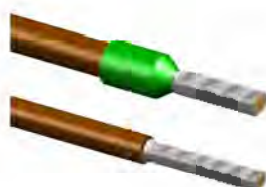

0.25mm <sup>2</sup> to 10mm <sup>2</sup>	<b>4300-3127</b>
16mm <sup>2</sup> and 25mm <sup>2</sup>	<b>4300-3153</b>
35mm <sup>2</sup> and 50mm <sup>2</sup>	<b>4300-3154</b>

Die Set with 6 cavities for bootlace ferrules 0.25 - 0.75mm<sup>2</sup>, 1 - 1.5mm<sup>2</sup>, 2.5mm<sup>2</sup>, 4mm<sup>2</sup>, 6mm<sup>2</sup> and 10mm<sup>2</sup>

Die Set with 2 cavities for bootlace ferrules 16mm<sup>2</sup> and 25mm<sup>2</sup>

Die Set with 2 cavities for bootlace ferrules 35mm<sup>2</sup> and 50mm<sup>2</sup>



0.1mm <sup>2</sup> to 1mm <sup>2</sup>	<b>4300-3150</b>
0.5mm <sup>2</sup> to 2.5mm <sup>2</sup>	<b>4300-3151</b>
0.5mm <sup>2</sup> to 6mm <sup>2</sup>	<b>4300-3146</b>

Die Set with 3 cavities for open barrel push on connectors 2.8/110 receptacles wire sizes 0.1mm<sup>2</sup> to 0.25mm<sup>2</sup>, 0.25mm<sup>2</sup> to 0.5mm<sup>2</sup> and 0.5mm<sup>2</sup> to 1mm<sup>2</sup>

Die Set with 2 cavities for open barrel push on connectors 4.8/187 receptacles wire sizes 0.5mm<sup>2</sup> to 1.0mm<sup>2</sup> and 1.5mm<sup>2</sup> to 2.5mm<sup>2</sup>

Die Set with 2 cavities for open barrel push on connectors 6.3/250 receptacles wire sizes 0.5mm<sup>2</sup> to 1mm<sup>2</sup>, 1.5mm<sup>2</sup> to 2.5mm<sup>2</sup> and 4mm<sup>2</sup> to 6mm<sup>2</sup>



ST, SC, SMA, SMB, SFR	<b>4300-3141</b>
-----------------------	------------------

Die Set with 4 hex cavities, 4.52, 5.41, 3.84 and 3.25 (across flats). Principally for fibre optic connectors ST, SC, SMA, SMB, and SFR, but can be used on coax connectors requiring back shell crimp only.



**Mobile Crimp Tool**

Crimp tool & dies	Connector	Wire range	Part No.
		RG174 and RG179.	<b>4300-3140</b>
		RG58, RG59, RG62 and RG71.	<b>4300-3136</b>
		RG6, RG59.	<b>4300-3138</b>

Die set with 3 hex cavities 4.52mm, 3.25mm, 1.69mm and one square shaped cavity, 0.7mm for RG174 and RG179 co-ax cables for BNC and TNC connectors.

Die set with 3 hex cavities 6.48, 5.41 and 1.68 for RG58, RG59, RG62 and RG71 co-ax cables for BNC and TNC connectors.

Die set with 2 hex cavities 8.23mm and 9.14mm for RG6 and RG59 co-ax cables for CATV connectors.

		RJ45 8/8	<b>4300-3144</b>
		RJ11, 6/6, 6/4 and 6/2	<b>4300-3132</b>

Die set for RJ45 modular connectors.

Die set for RJ11 modular connectors.

		0.14 - 1mm <sup>2</sup> , 1.5mm <sup>2</sup> , 2.5mm <sup>2</sup> , 4mm <sup>2</sup>	<b>4300-3147</b>
		6mm <sup>2</sup> and 10mm <sup>2</sup>	<b>4300-3148</b>

Die set with 4 cavities for power connectors 0.14 - 1mm<sup>2</sup>, 1.5mm<sup>2</sup>, 2.5mm<sup>2</sup>, 4mm<sup>2</sup>

Die Set with 2 cavities for power connectors 6mm<sup>2</sup> and 10mm<sup>2</sup>

**Calibration Gauges**

For use with the multi-crimp tool 4300-3149.

Go/No-go gauges for an easy way to ensure correct tool performance.

Simple to use with Go and No-Go positions for each die aperture.

Die Ref.	Part No.	Die Aperature
4300-3129	<b>GNG-4300-3129-R</b>	Red
4300-3129	<b>GNG-4300-3129-B</b>	Blue
4300-3128	<b>GNG-4300-3128-Y</b>	Yellow

Gauges for un-insulated die sets available on request



**Embla - Self-adjusting Cut and Strip Tool**

**Stripping tools**

**Wire range**

**Part No.**



0.02mm<sup>2</sup> to 10mm<sup>2</sup>  
(PVC wires)

**4320-0612**

Self-adjusting cut and strip tool with a straight blade cassette to strip PVC insulation wires from 0.02mm<sup>2</sup> to 10mm<sup>2</sup>. Featuring an insulation depth adjustment to cater for thick and thin insulations. The cassettes are easy to change without the use of any tools. Embla is designed to work on a variety of wires by exchanging the cassettes to suite the wire type.



0.02mm<sup>2</sup> to 10mm<sup>2</sup>  
(PVC wires)

**4320-0614**

Replacement straight blade (PVC wires) stripping cassette for 4320-0612



0.1mm<sup>2</sup> to 4mm<sup>2</sup>  
(PTFE and other  
hard insulation  
wires e.g. Solar  
Cable)

**4320-0615**

Replacement V-blade cassette for 4320-0612 designed to strip PTFE style hard insulation wires from 0.1mm<sup>2</sup> to 4mm<sup>2</sup>



4mm<sup>2</sup> to 16mm<sup>2</sup>  
(PVC wires)

**4320-0669**

Replacement cassette for 4320-0612 designed to strip PVC wires from 4mm<sup>2</sup> to 16mm<sup>2</sup>



**Tor - Heavy Duty Cable Stripping Tool**

Stripping tool

Wire range

Part No.



4.5mm to 40mm diameter

**4320-0617**

Tor is a professional stripping tool for cables of all insulation types. The tool is designed to have interchangeable hooks so that one tool caters for wires with insulations up to 4.5mm thick and diameters from 4.5mm to 40mm (standard hook covers 4.5mm to 25mm diameter, the large hook covers 20-40mm diameter).



- Supplied with two hooks for rotary, spiral or longitudinal stripping
- Simple twist of handle turns blade to produce desired cut
- Spiral stripping ability allows for easy removal of difficult insulations
- Spare blades can be stored inside the tool body
- Blade automatically returns to the start position at the end of each cycle



Up to 4.5mm thick insulations

**4320-0618**

Replacement blade for 4320-0617.

**Oden - Precision Stripping Tool**

2.5mm to 11mm diameter



- Supplied with two hooks for rotary, spiral or longitudinal stripping
- Simple twist of handle turns blade to produce desired cut
- Spiral stripping ability allows for easy removal of difficult insulations
- Spare blades can be stored inside the tool body
- Blade automatically returns to the start position at the end of each cycle

### **Crimp tool for Pre-insulated Terminals - KSA0760C**

High specification hand ratchet tool to crimp pre-insulated terminals 0.5mm<sup>2</sup> - 6.0mm<sup>2</sup>.

- Go/No-Go gauges available to ensure correct tool performance
- Ratchet system to guarantee a fully closed crimp
- Release mechanism if the crimping system must be interrupted
- Symmetrical crimping - offering right-hand or left-hand operation
- Die nests leave imprints on terminal insulation sleeve to show identification
- Unique mechanism which reduces handle force significantly
- Ergonomically designed handles to reduce risk of repetitive strain injuries (RSI)



### **Calibration Gauges**

**For use with the KSA0760C tool.**

Go/No-go gauges for an easy way to ensure correct tool performance. Simple to use with Go and No-Go positions for each die aperture. Available on request.



### **Crimp Tool for Pre-insulated Terminals - RPI-CH**

Hand ratchet tool with cushion handles to crimp pre-insulated terminals  $0.5\text{mm}^2$  -  $6.0\text{mm}^2$ . For precise crimping both conductor and insulation in one easy action. New improved ergonomic design for easy crimping.  
Length: 250mm Weight: 0.59kg



### **Crimp Tool for Pre-insulated Terminals - RPI**

Hand ratchet tool to crimp pre-insulated terminals  $0.5\text{mm}^2$  -  $6.0\text{mm}^2$ . For precise crimping both conductor and insulation in one easy action. New improved ergonomic design for easy crimping.  
Length: 230mm Weight: 0.6kg

### **Crimp Tool for Pre-insulated Terminals - RPI-RA**

Hand ratchet tool to crimp right-angled pre-insulated female push-on terminals  $1.5\text{mm}^2$  (red) and  $2.5\text{mm}^2$  (blue).  
Length: 242mm Weight: 0.54kg



### **Service Pliers - SPUI**

Service plier to crimp preinsulated and uninsulated terminals  $0.5\text{mm}^2$  to  $6.0\text{mm}^2$  with wire cutter and bolt cutter  
Length: 230mm Weight: 0.13kg

### **Crimp Tool for Un-insulated Terminals - RPU**

Hand ratchet tool to crimp un-insulated terminals  $0.5\text{mm}^2$  -  $10.0\text{mm}^2$ . New improved ergonomic design for easy crimping.  
Length: 230mm Weight: 0.6kg



### ***Crimp Tool for Un-insulated Terminals - RPT***

Hand ratchet tool to crimp push-on un-insulated flat-tab or open barrel terminals 0.5mm<sup>2</sup> - 6.0mm<sup>2</sup>.

New improved ergonomic design for easy crimping.

Length: 230mm Weight: 0.6kg



### ***Crimp Tool for Un-insulated Terminals - RP1516***

Hand ratchet tool to indent crimp un-insulated terminals 1.5mm<sup>2</sup> - 16mm<sup>2</sup>.

Length: 280mm Weight: 0.47kg

### ***Crimp Tool for Un-insulated Terminals - RP625***

Hand ratchet tool to indent crimp un-insulated terminals 6mm<sup>2</sup> - 25mm<sup>2</sup>.

Length: 350mm Weight: 0.7kg



### ***Crimp Tool for Un-insulated Terminals - RP16***

Hand ratchet tool to indent crimp un-insulated terminals 10mm<sup>2</sup> - 16mm<sup>2</sup>.

Length: 260mm Weight: 0.6kg



**Crimp Tool for Bootlace Ferrules - SPB0525**

Small non-ratchet plier to crimp bootlace ferrules 0.5mm<sup>2</sup> - 2.5mm<sup>2</sup>  
Length: 145mm Weight: 0.16kg



**Crimp Tool for Bootlace Ferrules - SPB07510**

Small non-ratchet plier to crimp bootlace ferrules 0.75mm<sup>2</sup> - 10mm<sup>2</sup>  
Length: 145mm Weight: 0.16kg

**Crimp Tool for Bootlace Ferrules - SPB0516**

Small non-ratchet plier to crimp bootlace ferrules 0.5mm<sup>2</sup> - 16mm<sup>2</sup>  
Length: 145mm Weight: 0.16kg



**Crimp Tool for Bootlace Ferrules - RPB01425**

Small hand ratchet tool to crimp bootlace ferrules 0.14mm<sup>2</sup> - 2.5mm<sup>2</sup>  
New improved ergonomic design for easy crimping.  
Length: 145mm Weight: 0.16kg

**Crimp Tool for Bootlace Ferrules - RPB0525**

Small hand ratchet tool to crimp bootlace ferrules 0.5mm<sup>2</sup> - 2.5mm<sup>2</sup>  
with unique single front or side loading die.  
New improved ergonomic design for easy crimping.  
Length: 205mm Weight: 0.40kg



**Crimp Tool for Bootlace Ferrules - RPB0256**

Small hand ratchet tool to crimp bootlace ferrules  
0.25mm<sup>2</sup> - 6.0mm<sup>2</sup> with unique self-adjusting, single entry, side  
loading die.  
Length: 175mm Weight: 0.35kg



**Crimp Tool for Bootlace Ferrules - RPB56**

Small hand ratchet tool to crimp bootlace ferrules 0.5mm<sup>2</sup> - 6mm<sup>2</sup>  
 New improved ergonomic design for easy crimping.  
 Length: 230mm Weight: 0.6kg



**Crimp Tool for Bootlace Ferrules - RPB07510**

Small hand ratchet tool to crimp bootlace ferrules 0.75mm<sup>2</sup> - 10mm<sup>2</sup>  
 Length: 175mm Weight: 0.35kg



**Crimp Tool for Bootlace Ferrules - RPB616**

Small hand ratchet tool to crimp bootlace ferrules 6mm<sup>2</sup> - 16mm<sup>2</sup>  
 Length: 230mm Weight: 0.6kg



**Crimp Tool for Bootlace Ferrules - RPB1635**

Small hand ratchet tool to crimp bootlace ferrules 16mm<sup>2</sup> - 35mm<sup>2</sup>  
 Length: 235mm Weight: 0.6kg



**Crimp Tool for Bootlace Ferrules - RPB2550**

Small hand ratchet tool to crimp bootlace ferrules 25mm<sup>2</sup> - 50mm<sup>2</sup>  
 Length: 235mm Weight: 0.6kg



**Crimp Tool for Bootlace Ferrules - RPB5095**

Small hand ratchet tool to crimp bootlace ferrules 50mm<sup>2</sup> - 95mm<sup>2</sup>  
 Length: 240mm Weight: 0.8kg



## Tooling



### **Large Hand Crimp Tool - CT1095i**

Mechanical indent crimp tool 10mm<sup>2</sup> - 95mm<sup>2</sup>. Change die size by a screw adjustment. Length: 570mm Weight: 3.2kg

### **Large Hand Crimp Tool - CT10240i**

Mechanical indent crimp tool 10mm<sup>2</sup> - 240mm<sup>2</sup>. Change die size by screw adjustment. Length: 520mm Weight: 4Kg



### **Large Hand Crimp Tool - CT650H**

Mechanical crimp tool with revolving hexagonal crimp dies 6mm<sup>2</sup> - 50mm<sup>2</sup>. With insulated grip handles. Length: 380mm Weight: 1.5kg

### **Large Hand Crimp Tool - CT6120H**

Mechanical crimp tool with revolving hexagonal crimp dies 6mm<sup>2</sup> - 120mm<sup>2</sup>. With insulated grip handles. Length: 650mm Weight: 3.8kg



### **Large Hand Crimp Tool - CT25150H**

Mechanical crimp tool with revolving hexagonal crimp dies 25mm<sup>2</sup> - 150mm<sup>2</sup>. With insulated grip handles. Length: 650mm Weight: 3.9kg

### **Hand Ratchet Crimp Tool - RT10150H**

Hand ratchet hexagon crimp tool 10mm<sup>2</sup> - 150mm<sup>2</sup>. 5 pairs of hexagonal profile dies make up full set. Tool is supplied with case and die sets are ordered as required. Length: 420mm Weight: 2.0kg  
Part No. for tool complete with case and full set of dies: RT10150H-C



## Hydraulic Crimp Tool - HH1070H

Hand hydraulic crimp tool for copper tube terminals 10mm<sup>2</sup> - 70mm<sup>2</sup>. Supplied in moulded one-piece case complete with hexagonal crimp dies 10-70mm<sup>2</sup>.  
Length: 310mm Weight: 1.9kg



## Hydraulic Crimp Tool - HHI-10150

Hand hydraulic indent crimp tool with revolving nest die and indentors 10mm<sup>2</sup> - 150mm<sup>2</sup> complete with case. Head rotates 180° and with a two stage pump for fast pumping. Tool is only sold complete with dies and case. OUTPUT: 8 Ton Length: 530mm Weight: 5.0kg



## Hydraulic Crimp Tool - HHI-10400

Hand hydraulic indent crimp tool 10mm<sup>2</sup> - 400mm<sup>2</sup>. Tool is only sold complete with case and full set of dies. Head rotates 180° and with a two stage action pump. OUTPUT: 20 Ton.  
Length: 560mm Weight: 8.0kg



## Hydraulic Crimp Tool - HH10150H

Lightweight and compact hand hydraulic hexagon crimp tool 10mm<sup>2</sup> - 150mm<sup>2</sup>. Head rotates 180°, ideal for close quarter work. Supplied complete with case. Hexagonal profile dies ordered as required. OUTPUT: 5.2 Ton. Length: 370mm Weight: 2.0kg  
Part No. for tool complete with case and full set of dies: HH10150H-C



## Hydraulic Crimp Tool - HH10400H

Hand hydraulic hexagon crimp tool 10mm<sup>2</sup> - 400mm<sup>2</sup>. Head rotates 180°. Supplied complete with case. Hexagonal profile dies ordered as required. 13 pairs make full set. OUTPUT: 13 Ton. Oil capacity: 200cc.  
Length: 650mm Weight: 7.4kg  
Part No. for tool complete with case and full set of dies: HH10400H-C  
N.B. This tool is available to hire - see page 159





## Hydraulic Crimp Head - HCH10400

Hydraulic C head only to accept hexagon profile die sets 10mm<sup>2</sup> - 400mm<sup>2</sup>. Dies ordered as required, 13 pairs make full set and can be used with hydraulic or pneumatic pump. OUTPUT: 12 Ton. Jaw opening 30mm. Length: 260mm Weight: 4.6kg  
N.B. This tool is available to hire - see page 159



## Hydraulic Crimp Head - HCH10630

Hand held hydraulic crimp head to accept hexagon profile die sets 10mm<sup>2</sup> - 630mm<sup>2</sup>. To crimp 10mm<sup>2</sup> - 400mm<sup>2</sup>, 13 pairs of C dies required. To crimp 500mm<sup>2</sup> & 630mm<sup>2</sup> you will also require: D410-500 (500mm<sup>2</sup>) cast die set, D410-630 (630mm<sup>2</sup>) cast die set. DA630 adaptor is required to use with C dies 10mm<sup>2</sup> - 400mm<sup>2</sup>. OUTPUT: 23 Ton. Length: 320mm Weight: 5.6kg  
N.B. This tool is available to hire - see page 159

## Hydraulic Pump - HFP1

Two stage foot operated hydraulic pump with automatic release when 700bar/10,000psi pressure is achieved. Complete with 2m hose, male quick release connector and case. For use with the SWA range of hydraulic crimping heads and cable cutters. OUTPUT: 700bar/10,000psi - weight 13.5kgs. Length: 710mm Weight: 13.7kg  
N.B. This tool is available to hire - see page 159



## Hydraulic Air Pump - PFP



A lightweight single speed efficient pneumatic hydraulic foot pump suitable for the SWA range of hydraulic crimping heads and cable cutters. Supplied with 2m hydraulic hose and 3/8" quick release male coupling. Dimensions: 380mm x 150mm x 205mm, Weight: 6.7kg  
MAX. PRESSURE: 1st stage air pressure 70-120psi (6-10Kg/cm<sup>2</sup>)  
2nd stage 700kg/cm<sup>2</sup>  
OUTPUT PER STROKE: Oil delivery/ICC stroke 300CC/min  
RESEVOIR CAPACITY: 700CC  
OIL PORT THREAD: 1/4 NPT

## Battery Operated Crimp Tool - BCT10400-LPG

Battery operated crimp tool (14.4 volt) 10 - 400mm<sup>2</sup> (42mm jaw opening), rotating head, c/w case, charger & 2 batteries.  
Dies supplied separately.

Length 418mm, Width 300mm, Height 78mm, Weight 8.0kg



## Battery Operated Crimp Tool - BCT10400-SPG

Battery operated crimp tool (14.4 volt) 10 - 400mm<sup>2</sup> (25mm jaw opening), rotating head c/w case, charger & 2 batteries.  
Dies supplied separately.

Length 300mm, Width 300mm, Height 78mm, Weight 7.0kg

## Battery - BCT-BAT

Replacement 14.4 volt battery (Ni-MH) for any of the BCT & BCC range of crimping & cable cutting tools.

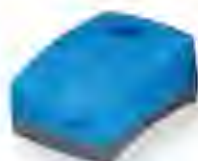

## Battery Charger - BCT-CH

Battery charger (20min charging time) for the 14.4 volt range of batteries.  
Supplied with power lead & 13A plug top.

## Battery Operated Crimp Tool - BCT10400-L

Battery operated crimp tool (14.4 volt) 10 - 400mm<sup>2</sup> (42mm jaw opening), rotating head c/w case, charger & 2 batteries. Dies supplied separately.

Length 490mm, Width 240mm, Height 70mm, Weight 8.5kg



## Battery Operated Crimp Tool - BCT10400-S

Battery operated crimp tool (14.4 volt) 10 - 400mm<sup>2</sup> (25mm jaw opening), rotating head, c/w case, charger & 2 batteries. Dies supplied separately.

Length 330mm, Width 240mm, Height 70mm, Weight 7.0kg

### **Battery Operated Cable Cutter - BCC-40**

Battery operated cable cutter (14.4 volt) suitable for armoured cable up to 40mm diameter. c/w case, charger & 2 batteries.

Length 428mm, Width 310mm, Height 75mm, Weight 5.6kg



### **Battery Operated Cable Cutter - BCC-52**

Battery operated cable cutter (14.4 volt) suitable for armoured cable up to 52mm diameter. c/w case, charger & 2 batteries.

Length 428mm, Width 310mm, Height 75mm, Weight 9.2kg

### **Battery Operated Cable Cutter - BCC-85**

Battery operated cable cutter (14.4 volt) suitable for armoured cable up to 50mm diameter and un-armoured cable up to 85mm diameter. c/w case, charger & 2 batteries.

Length 505mm, Width 310mm, Height 75mm, Weight 6.5kg



### **Mains Power Converter - MPC110**

110 AC mains power converter for the BCT & BCC range of crimping & cable cutting tools.

### **Mains Power Converter - MPC240**

220 AC mains power converter for the BCT & BCC range of crimping & cable cutting tools.



### **Electrical Hydraulic Pump - EHP110**

Electrical hydraulic pump: 110 volt c/w hose, remote hand control. For use with the SWA range of hydraulic crimping heads and cable cutters. Length 355mm, Width 260mm, Height 160mm, Weight 6.6kg

### **Electrical Hydraulic Pump - EHP240**

Electrical hydraulic pump: 240 volt c/w hose, remote hand control. For use with the SWA range of hydraulic crimping heads and cable cutters. Length 355mm, Width 260mm, Height 160mm, Weight 6.6kg



## Electrical Crimping Unit - Crimpatic1

- Bench mounted electric tool for a variety of terminals - pre-insulated, un-insulated, flat-tab/open barrel, bootlace ferrules
- Consistent crimp performance
- Reduces operator fatigue

Output Force: 12.7 kn

Main Power Connection: 240 volts

Power Consumption: 90 W

Crimping Time: 1.5 secs. (60Hz) 1.8 secs. (50Hz)

Weight: 2.7 kg

Dimensions (mm): Length 325 - Width 265  
- Height 150



## Pneumatic Crimp Tool - PCH1

- Bench mounted, air operated tool for a variety of terminals
- Consistent crimp performance
- Reduces operator fatigue

Air Pressure: 5-6bar (80-115psi)

Air consumption: 34L/min at 30 crimps per min

Weight: 2.7kg

Dimensions (mm): Length 225 - Width 135  
- Height 90

**PCH1** - Pneumatic crimp head



**PF1** - Foot pedal c/w hose



Dies listing for Crimpatic1 or PCH1

Part No.	Range (mm <sup>2</sup> )	Terminals
PHP156	0.5 - 6	Pre-insulated
PHU156	1.5 - 6	Un-insulated
PHFT156	0.5 - 6	Un-insulated 'Flat tab'
PHBLF4	0.5 - 4	Bootlace/Cord-end Ferrules
PHBLF6	0.75 - 6	Bootlace/Cord-end Ferrules
PHBLF10	6 - 10	Bootlace/Cord-end Ferrules
PHBLF25	10 - 25	Bootlace/Cord-end Ferrules
PHBLF35	16 - 35	Bootlace/Cord-end Ferrules
PHBLF50	25 - 50	Bootlace/Cord-end Ferrules

## Tooling



All items on this page are not suitable for armoured cables

### **Non-ratchet Cable Cutter - CC10**

Small hand cable snipper up to 10mm<sup>2</sup> singles with lockable jaws.  
Length: 165mm Weight: 0.2kg



### **Non-ratchet Cable Cutter - CC35**

Small hand cable cutter up to 35mm<sup>2</sup> single core copper/aluminium cable with wire stripping facility. Length: 210mm Weight: 0.3kg

### **Non-ratchet Cable Cutter - CC50**

Small hand cable cutter up to 50mm<sup>2</sup> single core copper/aluminium cable.  
Length: 235mm Weight: 0.4kg



### **Non-ratchet Cable Cutter - CC120**

Small heavy duty cable cutter up to 120mm<sup>2</sup> single core copper/aluminium cable.  
Length: 320mm Weight: 0.7kg

### **Non-ratchet Cable Cutter - CC240**

Large heavy duty cable cutter up to 240mm<sup>2</sup> single core copper/aluminium cable. Length: 600mm Weight: 1.8kg



### **Non-ratchet Cable Cutter - CC500**

Large heavy duty cable cutter up to 500mm<sup>2</sup> single core copper/aluminium cable. Length: 810mm Weight: 1.25kg

## Tooling

### Ratchet Cable Cutter - RCC240

Hand ratchet cable cutter. Suitable for cables up to 240mm<sup>2</sup> single core copper/aluminium cable.

Length: 260mm Weight: 0.58kg

N.B. Not suitable for armoured cable.



### Ratchet Cable Cutter - RCC400HD

Hand ratchet heavy duty cable cutter with extendable handles. Suitable for cables up to 400mm<sup>2</sup> single core copper/aluminium cable. Length: 240mm (290mm with handles extended) Weight: 0.98kg

N.B. Not suitable for armoured cable.



### Ratchet Cable Cutter - RCC32A

Ratchet cable cutter with extendable handles suitable for armoured cables up to 32mm diameter. Supplied in case.

Length 310mm (380mm when handles extended)

Weight: 3.0kg



### Ratchet Cable Cutter - RCC70A

Ratchet cable cutter with extendable handles suitable for armoured cables from 11.5mm to 39mm diameter (up to 70mm<sup>2</sup> 4 core PVC/SWA/PVC). Supplied in case.

Length: 380mm (485mm when handles extended) Weight: 3.2kg



### Hydraulic Cable Cutter - HHC50

Hand hydraulic cable cutter suitable for cable up to 50mm diameter - copper/aluminium cable and armoured cable up to 40mm diameter. Supplied in steel case.

Cutting force: 12 Ton.

Length: 630mm Weight: 7.1kg



### Hydraulic Cable Cutting Head - HC85

Hydraulic cable cutter for use with hydraulic foot pump (HFP1), suitable for cable up to 85mm diameter - copper/aluminium cable and armoured cable up to 50mm diameter. Supplied in steel case.

Cutting force: 7.5 Ton. Length: 465mm Weight: 7.9kg

N.B. This tool is available to hire. See page 151.

### Hydraulic Cable Cutting Head - HC100

Hydraulic cable cutter for use with hydraulic foot pump (HFP1), suitable for cable up to 100mm diameter - copper/aluminium cable and armoured cable up to 75mm diameter. Supplied in steel case.

Cutting force: 7.5 Ton. Length: 515mm Weight: 8.4kg

N.B. This tool is available to hire. See page 151.



## Tooling

For un-armoured cables.

### Wire Stripper - ESI

Sprung handle wire stripper for twin and earth cable up to 2.5mm<sup>2</sup> complete with crimping and cutter facility.



### Wire Stripper - WS4

Sprung handle wire stripping tool for single cable 0.5mm<sup>2</sup> - 4mm<sup>2</sup>

### Wire Stripper/Cutter/Pliers - WSC6

Sprung wire stripper/cutter/pliers for single cable 0.5mm<sup>2</sup> - 6mm<sup>2</sup> complete with lockable jaws.



### Cable Stripper - CCS359

Universal cable stripper for multi-conductor cable 3.2mm - 9mm diameter.

### Wire Stripper - WS026

Automatic wire stripper with adjustable stripping length and jaw tension control. Self-adjusting with hardened steel blades. Integral wire cutter (for single wires). Suitable for cables 0.2mm<sup>2</sup> - 6mm<sup>2</sup>.



### Trunking/Conduit Cutter - M42

Hand ratchet cutter for both mini trunking and round PVC conduit up to maximum diameter 1 1/4 inch. Complete with mitre block.

## Impact and Punch Down Tool - IPDT-KR

Impact action inserts and trims the wire simultaneously when inserting in IDC terminals as found on telephone line boxes, the BT ADSL adaptors and most professional telephony fittings, network/telecom patch panels and sockets, and all over the professional telecom world.

Set the wire in the terminal blades and press down gradually. At a preset pressure the tool head impact action triggers and completes the insertion (with a metal insertion blade), while a small cutting blade trims the excess wire off.



IPDT-KR

Part No.	Suitable for terminal block type
IPDT-KR	Krone

## Modular Crimp Tool Kit - MCK

Modular crimp tool kit contains:

**MCT** modular crimping tool for 8P8C/RJ-45, 6P/RJ-12, RJ-11 & 6P2C PLUG

**CCS359** coaxial cable stripper 3.5 - 9mm max.

**IPDT-KR** impact and punch down tool,

(Tools available separately)



MCK



MCT



CCS359



IPDT-KR



## Tooling

### Cable Tie Tensioning Tool - CTG2248

Moulded cable tie tensioning tool complete with cut off facility for nylon ties 2.2mm - 4.8mm width.



### Cable Tie Tensioning Tool - CTG2248MET

Metal cable tie tensioning tool with cut off facility for nylon ties 2.2mm - 4.8mm width.

### Cable Tie Tensioning Tool - CTG3690

Metal cable tie tensioning tool with cut off facility for nylon cable ties 3.6mm - 9.0mm width.



### Cable Tie Tensioning Tool - SSTCT1

Cable tie tensioning tool complete with cut-off facility for stainless steel cable ties up to 9mm diameter. Semi-auto model which tightens/tensions the tie. After tensioning the tie, press down the steel bar and the excess tie is cut cleanly leaving a flush fitting.



### Hot Air Guns

- Ideal for the application of heat shrinkable products
- Available in both 240 volt and 110 volt
- Electronically monitored with variable settings for high and low temperatures
- Supplied with reflection and heat reducing nozzles
- Supplied fitted with plugs as standard
- CE approved



Part No.	Voltage	Output	Temperature Range	Air Flow Max
HAG110	110V	1500 watt	50-500°C	450 l/min
HAG240	240V	1500 watt	50-500°C	450 l/min



# EARTHING COMPONENTS & ACCESSORIES

## EARTHING COMPONENTS & ACCESSORIES



**Copper Bonded Grounding Rod..... 179**



**Earth Rod Accessories..... 179**



**Copper Alloy Clamps..... 180**



**Earth Clamps..... 180**



**Tape Clips & Clamps..... 181**



**Disconnecting Links..... 182**



**Earth Plate - Lattice Copper..... 182**



**Copper & Aluminium Tapes..... 183**



**Earth Rod Inspection Boxes & Earth Pits..... 184**

**Earthing Accessories..... 185-186**

# EARTHING COMPONENTS & ACCESSORIES



**Terminal Kit Box..... 185**



**Earth Terminal Blocks..... 185**



**Earth Clamp Set..... 185**



**Braided Earth Straps & Lead Assemblies..... 185**



**Flexible Copper Earthing Braid..... 185**

A correctly designed and installed earthing system provides a reliable safeguard to both lives and equipment by ensuring that any fault current is directed away from a structure and dissipated into the earth.

A good earth connection should have:

- Low electrical resistance to earth
- Good corrosion resistance
- The ability to carry the required current repeatedly

SWA earthing products ensure quality and simplicity for quick and easy installation.

## Copper Bonded Earth Rod

Manufactured from low carbon steel of grade BS970 or AISI 1018 with a high tensile strength of at least 600N/mm<sup>2</sup>. Low carbon steel cores are molecularly bonded with a 99.9% pure electrolytic copper up to a thickness of 0.25mm.

### Features:

- Perfectly bonded rod will last longer, drive easier and will not crack
- Corrosion resistance while providing the lowest resistance to ground
- Threads are rolled by roll threading process, which ensures that an even copper covering is maintained, even at the root of the thread - providing greater strength than a cut thread
- Thread rolling process raises the surface of the rod so that the thread diameter is greater than the shank diameter

Part No.	Rod Size Dia. x Length mm	Rod Dia. mm	Thread Dia. mm
<b>CER95-1200</b>	9.5 x 1200	9.5 (3/8")	Unthreaded
<b>CER16-1200</b>	16 x 1200	14.2 (5/8")	16 (5/8")

Solid copper rods available on request

- Clamps - see page 180
- Recommend install with driving stud and coupler



## Earth Rod Accessories

### Driving Stud

Used to drive the earth rod into the ground

Material: High tensile steel

Part No.	Size mm
<b>ERDS16</b>	16 (5/8")



### Coupler

Counter bored to enclose threads and protect from damage and corrosion

Material: Gunmetal

Part No.	Size mm
<b>ERC16</b>	16 (5/8")



# Earthing Protection

## Copper Alloy Clamps

- These clamps are made from copper alloy providing a strong resistance to corrosion.

### Rod to Tape Clamp

Part No.	Size mm	Max Conductor
ERTC16	16 (5/8")	26 x 12

### Rod to Cable Clamp

Part No.	Size mm	Max Conductor
ERCC95	9.5 (3/8")	35mm <sup>2</sup>
ERCC16	16 (5/8")	50mm <sup>2</sup>

### Rod to Cable Lug Clamp

Part No.	Size mm	Max Conductor
ERCLC95	9.5 (3/8")	35mm <sup>2</sup>
ERCLC16	16 (5/8")	50mm <sup>2</sup>



## Earth Clamps

- Safety clamps
- Manufactured from brass for indoor use or phosphor bronze for outdoor use
- Manufactured to BS 951:2009
- Embossed tags "safety electrical connection do not remove"

Part No.	Tag Colour	Description	Max Earth Conductor	Box Qty
SEC14	Red	Indoor use - dry, non corrosive to suit pipe dia. 12-32mm	1x10mm <sup>2</sup>	25
SEC14/3	Red	Indoor use - dry, non corrosive to suit pipe dia. 50-75mm	1x10mm <sup>2</sup>	20
SEC15	Blue	For outdoor corrosive, humid conditions to suit pipe dia. 12-32mm	1x10mm <sup>2</sup>	25
SEC15/3	Blue	For outdoor corrosive, humid conditions to suit pipe dia. 50-75mm	1x10mm <sup>2</sup>	20
SEC16	Green	For outdoor corrosive, humid conditions to suit pipe dia. 12-32mm	2x16mm <sup>2</sup>	25
SEC16/3	Green	For outdoor corrosive, humid conditions to suit pipe dia. 50-75mm	2x16mm <sup>2</sup>	20



# Earthing Protection

## DC Tape Clip

- Used for supporting bare copper tape  
Material: Brass

Part No.	Conductor Size mm
ETC253	25 x 3
ETC506	50 x 6



## Square Tape Clip

- Used for supporting bare copper tape  
Material: Brass

Part No.	Conductor Size mm
ESTC253	25 x 3
ESTC506	50 X 6



## Oblong Test Clamp

- Used for supporting bare copper tape  
Material: Brass

Part No.	Conductor Size mm
EOTC253	25 x 3
EOTC506	50 x 6



## DC Tape Clip - Aluminium

- Used for supporting bare aluminium tape  
Material: Aluminium

Part No.	Conductor Size mm
ETC253-ALU	25 x 3



## Plastic DC Clip - High Impact PVC

- Used for supporting bare copper tape  
Material: PVC

Part No.	Conductor Size mm
EPTC253- GREY	25 x 3
EPTC253-GREEN	25 x 3
EPTC253-BROWN	25 x 3



# Earthing Protection

## Earth Bars & Disconnecting Links

- Bar: 50mm x 6mm hard drawn copper bar to BS EN 13601 Base: Plastic  
Fitting: M10 hexagon head screws Current Capacity: 700-800 amps

Part No.	Description	Length mm	Width mm
IRHI	Insulated red hexagonal adaptor		
EDL	Disconnecting Link	125	90
EDL4-EB	Four-way earth bar	420	90
EDL4-S	Four-way earth bar with single disconnecting link	475	90
EDL6-S	Six-way earth bar with single disconnecting link	575	90
EDL6-T	Six-way earth bar with twin disconnecting link	650	90
EDL6-EB	Six-way earth bar	520	90
EDL8-S	Eight-way earth bar with single disconnecting link	585	90
EDL8-T	Eight-way earth bar with twin disconnecting link	670	90
EDL10-S	Ten-way earth bar with single disconnecting link	735	90
EDL10-T	Ten-way earth bar with twin disconnecting link	820	90
EDL12-S	Twelve-way earth bar with single disconnecting link	835	90
EDL12-T	Twelve-way earth bar with twin disconnecting link	920	90

N.B. Other combinations available on request.



## Earth Plate - Lattice Copper

Part No.	Width (mm)	Length (mm)	Thickness (mm)
ELC600-3	600	600	3
ELC900-3	900	900	3

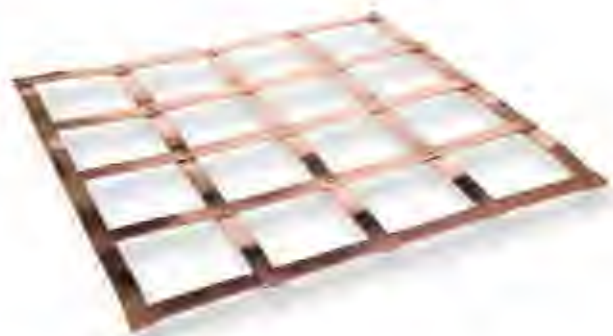



# Earthing Protection

## Copper Tape

- High conductivity copper tape to BS 1432-C101/C103
- Available in bare copper or PVC insulated

Part No.	PVC Colour	Width mm	Thickness mm	Coil Size m
BCT253-25	Bare	25	3	25
BCT253-50	Bare	25	3	50
BCT506-25	Bare	50	6	25
GECT253-25	Green	25	3	25
GECT253-50	Green	25	3	50
BROECT253-25	Brown	25	3	25
GRYECT253-25	Grey	25	3	25

Available in cut lengths (per metre)



## Aluminium Tape

- Bare aluminium tape to BS 2898-1350

Part No.	PVC Colour	Width mm	Thickness mm	Coil Size m
BAT253-25	Bare	25	3	25

Available in cut lengths (per metre)



## Earthing Accessories

### Earth Rod Inspection Box

Part No.	Dimensions mm		
	Width	Length	Depth
GEB-UK	95	95	55
GEB (for Irish market)	95	95	55



**Material:** Polyamide 6/6.  
Complete with fixing screws.

### Earth Pit

Used to allow access to the connection between the earth rod and conductor.

#### Plastic Earth Pit

The lightweight, heavy duty inspection pit with its unique design has resulted in performance capabilities superior to the traditional concrete pit, at a similar cost. Manufactured from a high performance polymer, the pit is UV stable and chemical resistant. In addition, the features incorporated within its design ensure ease of storage, reduced transportation costs, ease of installation and ease of subsequent inspection and testing of the earth electrode system, therefore providing significant practical benefits to both installers and specifiers alike.

#### Features and benefits

- **Lockable jam free lid:** Once installed the lid can be Allen Key locked to prevent tampering with equipment. Once locked, the design of the lid is such that debris cannot become jammed between the lid and the surround. Supplied with Allen Key.
- **Screw retention facility:** The stainless steel, rustproof screws are snapped into the lid, preventing loss whilst in storage or on site. The screws may also be used to lift off the lid using special sockets.
- **Shatterproof material:** The high performance polymer is significantly less brittle than concrete, reducing the likelihood of wastage due to breakages.
- **Chemical resistance:** Resistant to most substances, including petrol, oil, diesel, bitumen and concrete.
- **UV Stability:** UV additive minimising the effects of direct sunlight.
- **Wide temperature applications:** Capable of withstanding a wide range of temperatures.
- **Central 70mm diameter rod location hole:** This ensures that the Earth Rod is centrally positioned, simplifying earth clamp connection.
- **Quality guarantee:** Fully compliant to BS EN 62305-3 and tested to BS EN 50164-5.

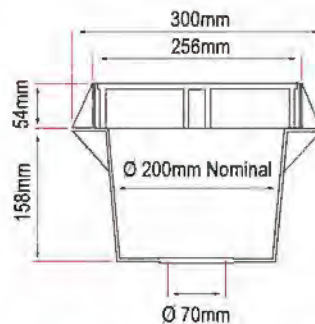

Patent No. GB 2261240 & EP 0541350

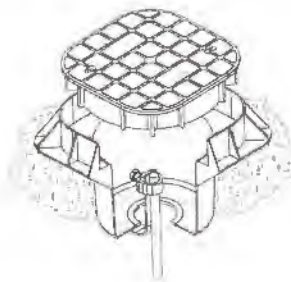

Part No.	Max Load (kg)
EIP-PL	5000

#### Concrete Earth Inspection Pit

- Suitable for most types of earthing and lightning protection installations
- The inspection pit protects the earth rod connection and makes it accessible for inspection

Part No.	Max. Load (kg)
EIP-CON	4500

Dimensions: 275mm (W) x 275mm (D) x 130mm (H)



## Earthing Accessories

### Terminal Kit Box - EK1016

Terminal kit box complete with hand ratchet crimp tool and a selection of 10mm<sup>2</sup> & 16mm<sup>2</sup> copper tube terminals. See also page 32.



### 4 Way and 8 Way Earth Terminal Blocks

**Material:** Brass Casting

**Finish:** Nickel Plated

Part No.	Cable Entry Hole Diameters		Length (mm)	Width (mm)	Pack Qty
4TB	1 x 6.5mm	3 x 5.5mm	54	19	1
8TB	2 x 6.5mm	6 x 5.5mm	88	19	1



4TB



8TB

### Earth Clamp Set

- Ideal for radiators, sink units, ducting, display units
- Easy to install, versatile, safe, reliable
- Pack comprises: 10 clamps, 10 ties, 10 safety labels and 1 allen key

Part No.	Pack Quantity
ECS-10	10



## Earthing Accessories

### Braided Earth Straps & Lead Assemblies



Braided earth straps & lead assemblies made to order to suit all requirements or to your specifications.

When placing an enquiry, please supply details of:

- Cross sectional area of cable or braid (inc. voltage or amp rating)
- Terminals or stud hole dimensions required.
- Required hole centre to hole centre dimensions.
- Any special requirements - such as restricted palm width for terminals.

### Flexible Flat Tinned Copper Earthing Braid

- Typical Uses:**
- Earthing connections
  - Power interconnection
  - Lightening protection



Part No.	Current Rating Amps	Nominal CSA mm <sup>2</sup>	Nominal Dimensions mm	Reel Qty (m)
BRDPL30	30	1.7	4 X 0.75	50
BRDPL60	63	7.5	10 X 1.5	50
BRDPL100	90	10	14 X 1.5	50
BRDPL120	120	16	19 x 2.0	50
BRDPL200	200	35	25 x 3.5	50

Available by the metre

# TAPES, SEALANTS & LUBRICANTS

# TAPES, SEALANTS & LUBRICANTS

	<b>LLFA® Tape.....</b>	<b>188-190</b>
	<b>PVC Adhesive Electrical Tape.....</b>	<b>191</b>
	<b>Self-Amalgamating Tape.....</b>	<b>192</b>
	<b>Denso Tape.....</b>	<b>192</b>
	<b>Gaffer Tape.....</b>	<b>192</b>
	<b>Underground Marking Tape.....</b>	<b>193</b>
	<b>Barrier and Hazard Warning Tape.....</b>	<b>193</b>
	<b>Electrical Weatherproof Compound.....</b>	<b>194</b>
	<b>Sealing Compound.....</b>	<b>194-195</b>
	<b>Electrical Joint Compound.....</b>	<b>195</b>
	<b>Cable Pulling Lubricant.....</b>	<b>196</b>
	<b>Hole Saws and Accessories.....</b>	<b>197</b>

# Tapes, Sealants & Lubricants

## LLFA® Compression Tape

**ALFA**

Repairs, seals and insulates in seconds!



**INDUSTRIAL**



**MAINTENANCE**



**ELECTRICAL**

Saving time, this rapidly applied solution, is saving money. Multipurpose industrial grade solution used to create high tension seals with exceptionally long life. This is one product that will deliver every time.

Repairs, seals and insulates. One product with many uses. For a multitude of applications, LLFA Tape is an effective yet robust repair that is waterproof, weatherproof, easily applied and endures extreme conditions.

Outstanding performance for high or low voltage insulation. Long lasting, water tight and robust. Used for bus bar insulation, cable jointing, connection weather proofing, and cable repair.

Compression Tape combines ultra fast self-fusion with high tensile strength

Approvals: BS EN50393:2006, BS EN150 4589-2:199, BS 6920:2000

**WRAS**  
APPROVED  
PRODUCT

- Water tight electrical cable jointing and termination
- Leaking pipe repair without reducing the pressure or turning off the flow
- High voltage insulation
- Highly UV resistant
- Exceptional lifespan even when buried or submersed
- Functions in low or high temperatures
- Non-toxic, safe for use in direct contact with drinking water
- Easily applied, instant repair
- Environmentally responsible, replacing hazardous materials
- Saves time and money

SEAL - **stretch** to Maximum (300%)

FINAL LAYER - Minimum Stretch



Scan to view Plumbing  
LLFA Tape demo



Scan to view Electrical  
LLFA Tape demo





Repairs, seals and insulates in seconds!



REPAIR

INDUSTRIAL



SEAL

MAINTENANCE



INSULATE

ELECTRICAL

## LLFA® Compression Tape

A self fusing tape utilised to insulate and seal electrical cable splices where high and low temperature stability is needed, and where moisture, weather and radiation resistance is required.

Mechanically it provides a high tension wrap that creates an enduring seal under extreme environmental conditions. Due to its remarkable properties, it is also used to repair punctured water, air and hydraulic pipes that are subject to pressure and temperature variants.



LLFA 40/1 Black



LLFA 40/1 Red

Part No.	Length (m)	Width (mm)
LLFA 40/1 Black	10.9	25.4
LLFA 40/1 Red	10.9	25.4
LLFA 12/1 Black	3.6	25.4
LLFA 12/1 Red	3.6	25.4



LLFA 12/1



Free dispenser supplied with 10 rolls of LLFA 12/1 (red or black)

## LLFA® 1m Dispenser Pack

1m length of LLFA 40/1 black/red tape cut into 3 equal lengths.

	Part No.
Single Pack	Box of 25 Packs
L40PK1M Black	L40PK1mBLK-BX (Black)
L40PK1M Red	L40PK1mRED-BX (Red)



## LLFA® Smooth

An insulating putty that is soft enough to mould into any cavity or change in diameter, yet consistent enough to hold its shape once applied. It is primarily used to prepare a ready surface to which LLFA® TAPE can be applied.

Part No.	Pack Wt (g)
LSP320	113



Repairs, seals and insulates in seconds!



REPAIR

INDUSTRIAL



SEAL

MAINTENANCE



INSULATE

ELECTRICAL

## LLFA® Compression Tape

LLFA® Compression Tape can be used as a stand alone product. It seals when applied with "maximum stretch", and gives mechanical protection when applied with "minimum stretch".

### Fusion

With LLFA® Compression Tape fusion is almost instantaneous. This is an important factor when splicing or protecting a connection that is subject to high humidity or even submergence.

### Electrical Insulation

Straight and branch joints spliced with LLFA®, from the smallest to the biggest cable size, have undergone European standard testing to BS EN 50393:2006. This jointing method has successfully met all the requirements of the standard to make it the first compression tape jointing solution available in the EU.

### Instant Leak Repair

LLFA® Compression Tape is used to repair leaking pipes without turning off the flow. A punctured hose or pipe tightly wrapped with LLFA® Compression Tape will immediately withstand internal pressure. The pressure will not push between the "fusing layers" because the fusion takes place so quickly (even when wet).

### Abrasion Resistance

LLFA® Compression Tape, due to its unique formulation and manufacturing process, is resistant to abrasion and split propagation. Applying a final layer with minimum tension will increase abrasion resistance.

### Temperature Stability

Other products decrease or lose adhesion in extreme cold or humid conditions. LLFA® Compression Tape as a "CLASS H" material will continue to perform at these temperatures. LLFA® does not have to be kept warm in the cold or vice versa.

### Environmentally Responsible

LLFA® Compression Tape is environmentally friendly and is replacing solutions that are hazardous. LLFA® Compression Tape is also classed as normal waste, and is approved by the Water Regulations Advisory Scheme for use in direct contact with drinking water, both hot and cold.

**Dielectric Strength** LLFA®40 = 400VPM (16,000V per 1mm)

**Tensile Strength** > 1200 PSI throughout temp range

**Breaking Strength** > 15 lbs

**Tear Resistance** > 125 PSI

**Water Absorption** << 0.5%

**Temperature Range** -90°C through to 260°C

**Elongation** > 325%

**Track Resistance** Prevent electrical conduction along its surface

**UV Resistance** Highly UV resistant

**Ozone Resistance** Highly ozone resistant

**Durometer Hardness** 55 - 65

**Adhesion (Fusion)** Standard requirement: "Tape shall not unwind more than 1.0 inch after 3 minutes with an attached load of 600g". Result: LLFA® Tape < 1 inch

**Acids and Alkaline** No negative effect from brief exposure to acid and alkaline and can withstand submersion up to 3 days

**Self Extinguishing** UL standard 94 rating V-0. Tested to IEEE383 and IEEE1212 for flammability - self extinguishes and will not propagate a flame

**Smoke Toxicity** NF X 70 - 100:2006 test results indicate a C.I.T. value of 5.20. BS6853: 1999: Annex B test results indicate an R-value of 0.37

**Water Safety** BD6920 results indicate that LLFA® Tape is suitable for use in direct contact with drinking water up to 85°C (WRAS Approved)

**Standard Compliance** BS EN50393:2006, BS6920, ASTM D2240, A-A-59163, ASTM D-149, ASTM D-412, MIL-I-46852, ASTM D2148, ASTM D3767 (LLFA® specifications meet other international standards not included in this list)

N.B. Full material safety data sheet available on request



# Tapes, Sealants & Lubricants

## PVC Electrical Insulation Tape

Based on a 0.11mm soft PVC film, coated with an aggressive rubber-resin adhesive with flame retardancy and good aging characteristics. Excellent conformability and high elongation at break. This tape is designed to comply with BS EN 60454 (BS 3924) standard. For use as electrical insulation on joints and splices on wires and cables, bundling, reinforcing, and colour identification.



Part No.	Width (mm)	Length (m)	Pack Qty
PVCT1920-*	19	20	10
PVCT1933-*	19	33	8

\*suffix black, blue, brown, green, grey, red, white, yellow, green/yellow

PVCT2533-*	25	33	6
------------	----	----	---

\* suffix black, blue, brown, grey, red, white, yellow, green/yellow

PVCT5033-*	50	33	1
------------	----	----	---

\* suffix black, blue, brown, green, grey, red, white, yellow, green/yellow

Properties	Unit	Spec
Total Thickness	mm	0.132 +/- 10%
Adhesion to Steel	kg/25mm	> 0.45
Adhesion to Backing	kg/25mm	> 0.45
Tensile Strength	kg/25mm	> 5.0
Elongation	%	> 125
Unwinding Force	g/19mm	> 400
Dielectric Breakdown	kv	> 5
Flammability	sec	< 15
Temp Range	°C	0 - 80

Test Method: EN 60454-1 / ASTM D-1000

Shelf Life: 12 months when stored in original carton at 23°C and 65% R.H.

Availability: Standard 20 & 33m rolls.

Above figures are for reference and cannot be treated as warranties. Customers are advised to test the material to determine the suitability against intended applications.

## Smartypak™

### Pack contains:

- 2x Black
- 2x White
- 1x Yellow
- 1x Blue
- 1x Grey
- 1x Brown
- 1x G/Yellow

All 19mm x 20m

Part No.	Length (m)	Width (mm)
PVCT1920SP	20	19

- For use as electrical insulation on joints and splices  
Ideal for bundling, reinforcing and colour identification
- Complies to: BS EN 60454 standard
  - Flame retardant
  - RoSH compliant



# Tapes, Sealants & Lubricants

## Self-Amalgamating Tape (EPR)

- Pliable
- High grade self-amalgamating tape
- EPR based

### Application

- Insulation of power and distribution cables up to 46kV
- Repair and bonds between numerous insulating & sheathing materials e.g. PE, XLPE, EPR, PVC, butyl, neoprene
- Sealing of moulds and reinforcing cable insulation

### Features

- Excellent physical and electrical properties that guarantee long life
- Good dielectric properties
- Extremely ductile
- Welds quickly to a homogeneous mass without cavities
- Non-tacky
- Easy to handle and apply
- Cleanly removable when cut



Colour: Black

Tensile strength	3.0N / mm <sup>2</sup>
Elongation at break	800%
Water absorption	0.05%
Electrolytic corrosion	None
Flammability	Polyethylene
Ozone resistance	Passed
Dielectric strength	46KV / mm
Dielectric constant (50Hz)	2.8
Power factor (50Hz)	0.006
Volume resistivity (20°C)	10 <sup>13</sup> Ohm-m
Temperature range	-40°C to + 100°C
- short-time up to	130°C

Part No.	Width (mm)	Length (m)	Thickness (mm)
CP62	19	10	0.75

## Denso Tape

- Self-adhesive petrolatum tape
- British Gas approved
- Requires minimal preparation
- Flexible
- Effective long term sealing and protection

**Applications:** Corrosion protection of pipes, valves, joints, metal surfaces, and cable above and below ground or under water.



Part No.	Length (m)	Width (mm)
DENSO TAPE 1050	10	50

Safety data sheet available on request.

## Gaffer Tape

Vinyl cloth reinforced tape with adhesive backing.

- The ideal maintenance aid - a must for temporary repair work
- Extra high performance, heavy-duty used in the engineering, aerospace and motor industries
- Very good temperature and UV stability
- Can be used inside or outdoors

Part No.	Colour	Width (mm)	Length (m)
GT5050	Grey	50	50



# Tapes, Sealants & Lubricants

## Underground Marking Tape

Part No.	Length (m)	Width (mm)	Colour	Tape description
UMT-EL	365	150	Yellow	Electrical Cable Below
UMT-STL	365	150	Yellow	Street Lighting Cable Below
UMT-TEL	365	150	Green	Telephone Cable Below

Other types and languages available to order.



## Cable Protection Tiles

- Wording 'CAUTION ELECTRIC CABLE BELOW'  
Other texts can be manufactured to order

Part No.	Length (mm)	Width (mm)	Thickness (mm)
UMCT150	1000	150	6

For more information see page 151.



## Barrier and Hazard Warning Tape

- A non-adhesive polythene barrier tape with highly contrasting coloured stripes which serve as a clear and visual warning and also present a barrier to areas that require to be cordoned off
- Suitable for a wide range of uses that include construction sites, factories or warehouses and many other situations where safety of personnel is of a priority
- Available in red/white and black/yellow diagonal stripes

Part No.	Length (m)	Width (mm)	Colour
BT100RW	100	75	Red/White
BT500RW	500	75	Red/White
BT100BY	100	75	Black/Yellow
BT500BY	500	75	Black/Yellow

Adhesive versions available to order



# Tapes, Sealants & Lubricants

## Electrical Weatherproof Compound - EWC1

(also known as R391)

### Seals and Protects

- Protects electrical connections from moisture and corrosive vapours and is widely used for a variety of electrical applications including work on junction and conduit boxes
- Possesses good insulating properties and helps to prevent short circuits due to dampness
- Is non-hardening and does not shrink, crack or peel thereby allowing the compound to be readily removed and replaced safely by hand

Specific gravity at 15.5°C	1.70
Flash point	+210°C
Operating temperature	-20°C to +80°C
Working voltage	1000 Volts max.
Volume resistivity at 20°C	$8 \times 10^{11}$ ohm-m
Weight	500g



## Sealing Compound - DUXSEAL

Duxseal is a universal sealing putty based on non-desiccative synthetic oil.

### Applications

- Wall ducts
- Cable ducts
- Electrical devices
- Drains
- Water installation

Colour: Grey  
Pack quantity: 454g

### Features

- Ease of use
- Excellent sealing on almost every material – including metal, concrete, stone, wood, glass, ceramics, enamel
- Firm consistency and easy modeling
- Extreme high resistance to water, gas, sand and condensation
- Temperature resistivity permanently up to 80°C (short-term up to 120°C)
- Excellent ageing characteristics
- Unlimited shelf life



## Sealing Compound - RMX

For filling cavities and making airtight and watertight joints, especially in electrical equipment to exclude moisture.

Part No.	Pack Size
RMX	100g

**Type:** Non oxidizing resin/oil based compound suitably filled with inert mineral fillers.

**Appearance:** Grey putty-like finish.

**Consistency:** Putty-like.

**Flash Point:** Minimum 200°C

**Temp. Range:** 150°C continuous.

**Breakdown Strength:** When tested in a cell with a 4mm gap at 18°C the compound withstood 25kV for 1 minute.



## Electrical Joint Compound - Unial Paste

- Recommended for use on aluminium to aluminium and aluminium to copper connections, on all bare conductors and busbars
- Assumes a high conductivity joint by sealing out air and moisture to prevent corrosion and reformation of oxide film

Part No.	Volume
UN225	225ml



## Cellpack Easy-Glide



### Time-saving and secure

Pulling new cables or wires in cable channels is tough - with EASY-GLIDE you get a perfect lubricant. Not only saving time, it also protects cable sheaths from damage, it is biologically safe and harmless to health. You can increase your productivity thanks to EASY-GLIDE.

### EASY-GLIDE Lubricant

EASY-GLIDE eases and accelerates the pulling of cables and wires through cable channels. Damage to the outer sheath will be avoided.

#### Properties

- Improved sliding effect
- Resistant to temperatures up to 82°C
- Non-corroding
- Non-flammable
- Pleasant smell
- Harmless composition
- Neither sticks or generates flakes
- Skin-friendly and easily washable
- Bio-degradable
- Refillable plastic bottle
- Non-stain to fabric and furnishings

#### Tests

Conforms to UL and CSA norms

#### Recommendations

Close after use.  
Store in a cool and dry place

#### Tips

EASY-GLIDE can be applied by hand.  
Apply uniformly.

Part No.	Contents	Container
EASY-GLIDE250	250ml	Plastic Bottle
EASY-GLIDE1050	1050ml	Plastic Bottle
EASY-GLIDE5000	5000ml	Plastic Bucket

# Hole Saws and Accessories

## Hole Saws

SWA offer a comprehensive range of quality hole saws specifically designed for the trade professional. Using premium quality materials each hole saw is of bi-metal construction for fast and effective performance.

The range is further complemented with the addition of a 6pc and 9pc kit supplied in a hand carry case.



- Full range from 14mm to 200mm
- Professional quality
- Variable pitch teeth for high speed clean cutting

- Strong and durable
- Value for money

Code	Hole Saw Sizes	
BMHS16	16mm	5/8"
BMHS20	20mm	25/32"
BMHS22	22mm	7/8"
BMHS25	25mm	1"
BMHS32	32mm	1 1/4"
BMHS38	38mm	1 1/2"
BMHS40	40mm	1 9/16"
BMHS44	44mm	1 3/4"

Code	Hole Saw Sizes	
BMHS51	51mm	2"
BMHS57	57mm	2 1/4"
BMHS64	64mm	2 1/2"
BMHS73	73mm	2 7/8"
BMHS76	76mm	3"
BMHS83	83mm	3 1/4"
BMHS102	102mm	4"

## Hole Saw Arbors and Drills

- For use with bi-metal hole saws. Arbors supplied with Pilot Drill

Code	Size
ARBORS	
ARBOR1	14-30mm
ARBOR10	32-152mm

Code	Size
PILOT DRILLS	
HSSPD1	1/4" x 3"
HSSPD2	1/4" x 4"

## Electricians Hole Saw Kits

Professional bi-metal hole saw kits with variable pitch teeth.

**HSK1:** 9 piece kit contains: 16mm, 20mm, 25mm, 32mm, 40mm and 51mm hole saws, plus 1 x ARBOR1 and 1 x ARBOR10 plus 1 x 1/4" x 4" spare HSS Pilot Drill

**HSK2:** 6 piece kit contains: 64mm, 76mm, 89mm and 102mm holes saws plus 1 x ARBOR10 and 1 x 1/4" x 4" spare HSS Pilot Drill







# INDUSTRIAL AEROSOL PRODUCTS

## INDUSTRIAL AEROSOL PRODUCTS

	<i>Silicone Lubricant.....</i>	<i>200</i>
	<i>Cold Zinc Galv Spray.....</i>	<i>200</i>
	<i>Cutting &amp; Tapping Spray.....</i>	<i>200</i>
	<i>Clear Penetrating Oil.....</i>	<i>200</i>
	<i>Electrical Cleaner.....</i>	<i>201</i>
	<i>Air Duster Spray.....</i>	<i>201</i>
	<i>Line Marking Paint.....</i>	<i>201</i>

## Industrial Aerosol Products

### Silicone Lubricant

Part No. SS400

- Multi-purpose lubricant
- Plastic injection mould release
- Lubricates in clean areas
- Ideal for assembly work: i.e. wiring looms, plastic components, furniture, plumbing, electrical components
- Conveyor and curtain rails
- Clean lubricant
- Long lasting
- Invisible lubricant
- Prevents stick
- Contents: 400ml



### Cold Zinc Galv Spray

Part No. GLV400

- Protects against rust and corrosion
- Formulated to use as a touch up for marred, hot galv. surfaces
- Protects all iron and steel industrial equipment: piping ducts, water tanks, auto and marine parts
- Welds on both bare and previously galvanised surfaces
- Ideal for making good cut trunking: cable tray, channel etc
- Contents: 400ml



### Cutting & Tapping Spray

Part No. CTS400

- Drilling, tapping, reaming all metals
- Roata broaching
- Substitution of soluble oil for difficult metal cutting on machine tools
- Suitable for fine and difficult metal cutting operations
- Longer tool and drill life
- Improves finish
- Reduces downtime
- Superior to soluble and spindle oils
- Improves productivity
- Contents: 400ml



### Clear Penetrating Oil

Part No. CPO400

- Rapid penetration for all threaded components / locks etc
- Good corrosion protection
- Clean to use
- Both lubricates and penetrates components affected by corrosion
- Multiple uses
- Contents: 400ml



Material Safety Data Sheets available on request.

Visit: [www.swaonline.co.uk](http://www.swaonline.co.uk)

## Industrial Aerosol Products

### Electrical Cleaner

Part No. CBC400

- Cleans and degreases electrical contacts and sensitive components
- Leaves no residue
- Plastic compatible
- Switch cleaning
- Where fast action required
- Contents: 400ml



### Air Duster Spray

Part No. ADS400

- Clean pure gas for computers / photocopying equipment in the electronic market.
- Contents: 400ml



### Line Marking Paint

A lead free, resin based line marking paint in 750ml tins. These paints produce a hard wearing, fast drying line, and can be used on concrete, tarmac, wood and composites.

Part No.	Colour	Contents (ml)
LMP750-Y	Yellow	750
LMP750-R	Red	750
LMP750-W	White	750
LMP750-B	Blue	750



Material Safety Data Sheets available on request.  
Visit: [www.swaonline.co.uk](http://www.swaonline.co.uk)



# SUNDRIES



**Brass Stud Extensions.....204**



**Long Metric Screws.....204**



**Constant Force Springs.....205**



**Hose Clamps.....205**

# SUNDRIES

## Brass Stud Extensions

Part No.	Description	Pack Quantity
BSE-50	3.5mm brass stud extension	50

M3.5 extension studs used to extend the length of the switch or socket screws when the box is too deep in the wall for the fixing screw to reach. Simply screw the extension stud into the threaded lug in the box to extend it.



## Long Metric Screws

To suit switches/sockets

Part No.	Description	Pack Quantity
ZPS25	25mm x 3.5mm zinc plated screws	100
ZPS35	35mm x 3.5mm zinc plated screws	100
ZPS40	40mm x 3.5mm zinc plated screws	100
ZPS50	50mm x 3.5mm zinc plated screws	100
ZPS75	75mm x 3.5mm zinc plated screws	100



Part No.	Description	Pack Quantity
NPFS50	50mm x 3.5mm steel nickel plated flat countersunk head screws	100



Screws and Stud Extensions also available in Selekt-A-Box™ Range (see page 29)

## Constant Force Springs

A tightly coiled wound band manufactured from type 310 stainless steel. When extended a constant force is exerted and this is maintained as the spring is allowed to close. The full force is effective until the spring is in the fully closed position.

Constant force springs are used to provide reliable solderless continuity in earthing in low and medium voltage joints and termination systems.

Part No.	Cable Range Diameter (mm)	Internal Diameter (mm)	Width (mm)	Thickness of steel (mm)
CFS10	9-15	10	12.6	0.15
CFS16	14-22	16	19	0.25
CFS17	19-29	17	19	0.25
CFS22	24-37	22	19	0.25
CFS24	32-50	24	19	0.35
CFS32	44-70	32	19	0.50
CFS40	58-94	40	19	0.50



Sold in eaches

## Hose Clamps

AISI 430 stainless steel general purpose clamp with zinc plated carbon steel screw - for connecting pipes and hoses.

Part No.	Range (mm)	Pack Qty
JC13-20	13-20	100
JC18-25	18-25	100
JC25-35	25-35	100
JC27-40	27-40	100
JC35-50	35-50	100
JC40-55	40-55	100
JC55-70	55-70	100
JC70-90	70-90	100
JC85-100	85-100	Each
JC160-180	160-180	Each





Hose Clamps and Constant Force Springs also available in Selekt-A-Box™ Range (see page 29)

## Degree of Ingress Protection (IP Rating)





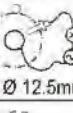
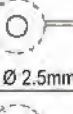
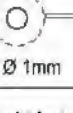

In accordance with EN 60529:1991

SWA cable glands comply with the requirements of EN 60529:1991 (IEC 529) in respect of IP ratings. Some cable gland types have been tested to IP66, whilst other types have been tested to IP66, IP67, and IP68, to a depth of 30 metres.

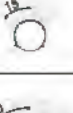

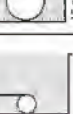

### Protection Against Solid Foreign Objects

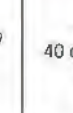
Tests	IP 1st Figure	Details	
		Designation	Scope of protection Explanation
	0	Non-protected	Non-protected
	1	Protected against solid foreign objects of 50mm diameter and greater.	Protected against access to hazardous parts with the back of a hand.
	2	Protected against solid foreign objects of 12.5mm diameter and greater.	Protected against access to hazardous parts with a finger.
	3	Protected against solid foreign objects of 2.5mm diameter and greater.	Protected against access to hazardous parts with a tool.
	4	Protected against solid foreign objects of 1.0mm diameter and greater.	Protected against access to hazardous parts with a wire.
	5	Dust protected.	Protected against access to hazardous parts with a wire.
	6	Dust-tight.	Protected against access to hazardous parts with a wire.

### Protection Against Water

Tests	IP 2nd Figure	Details
		Designation
	0	Non-protected
	1	Protected against drops of water falling vertically.
	2	Protected against drops of water falling at up to 15° from the vertical.
	3	Protected against spraying water at 60° from the vertical.
	4	Protected against splashing water from all directions.
	5	Protected against jet of water from all directions.
	6	Protected against jet of water of similar force to heavy seas.
	7	Protected against the effect of immersion.
	8	Protected against prolonged effects of immersion under pressure to a specified depth.

### Protection Against Impact

Tests						
IK	0	2	4	7	8	10
Details	Non-protected	Shock energy: 0.225 joule	Shock energy: 0.500 joule	Shock energy: 2.00 joule	Shock energy: 6.00 joules	Shock energy: 20.00 joules



## Hazardous Area Classifications

- Zone 0:** Zone in which an explosive atmosphere is constantly present, or present for long periods.  
(Rough guide: hazard present for more than 1,000 hours / year)
- Zone 1:** Zone in which an explosive atmosphere is likely to occur in normal operation.  
(Rough guide: hazard present between 10 & 1,000 hours / year)
- Zone 2:** Zone in which an explosive atmosphere is not likely to occur in normal operation and if it occurs it will exist only for a short time.  
(Rough guide: hazard present for less than 10 hours / year)

Guidance in the classification of hazardous areas is given in BS EN 60079-10:1996 IEC79-10

## Protection Concepts

Zone	Type of Protection Allowed
0	0 EEx ia – intrinsically safe apparatus or system Ex s – special protection (specifically certified for use in Zone 0)
1	Any type of protection suitable for Zone 0. EEx d – flameproof enclosure EEx ib – intrinsically safe apparatus or system EEx p – pressurized apparatus EEx e – increased safety EEx m – encapsulation
2	Any type of protection suitable for Zone 0 and/or Zone 1 * EEx a – oil immersion * EEx q – powder filling Ex N – non-sparking

\*In some countries the methods of protection against oil and powder are allowed in Zone 1.  
Please check before installation.



## SPECIALISED WIRING ACCESSORIES LTD

ABBAY MILLS, CHARFIELD ROAD, KINGSWOOD,  
WOTTON-UNDER-EDGE, GLOS. GL12 8RL, UK

TELEPHONE: (44) 01453 844333

FACSIMILE: (44) 01453 842224

E-MAIL: [sales@swaonline.co.uk](mailto:sales@swaonline.co.uk)

WEB: [www.swaonline.co.uk](http://www.swaonline.co.uk)

